

Profile

- Resolutions of max. 2560 pulses/revolution
- Through hollow shafts up to \varnothing 20 mm
- IP53 and IP63 protection categories
- Housing made of reinforced plastic
- Condensation permitted with sealed electronics unit
- Can be combined with the DA09S position indicator

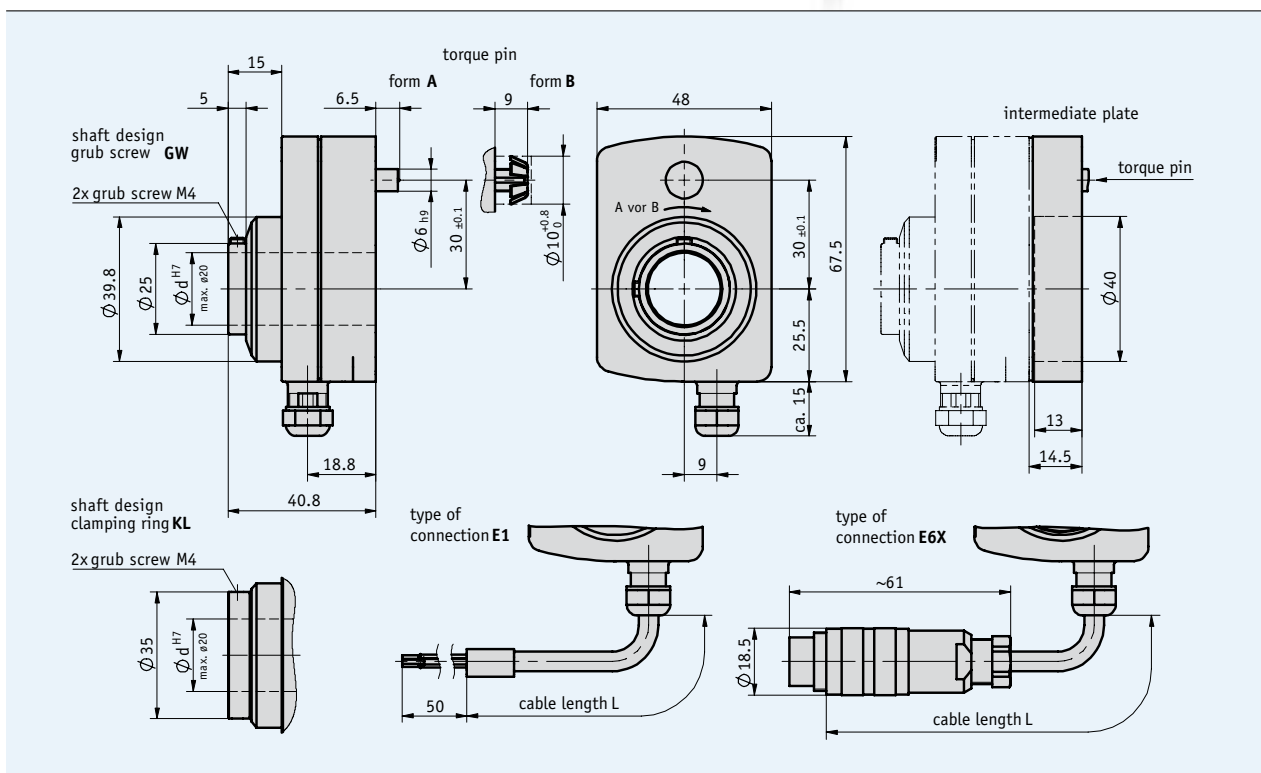

2.1



Mechanical data

Feature	Technical data	Additional information
Max. speed	6000 rpm 2000 rpm	with IP53 with IP63
Shaft moment of inertia	$\sim 0.15 \times 10^{-6} \text{ kgm}^2$	
Starting torque	$\leq 2 \text{ Ncm}$, IP53 $\leq 3.5 \text{ Ncm}$, IP63	at 20 °C
Weight	$\sim 0.12 \text{ kg}$	
Protection category	IP53 IP63	
Operating temperature	-20 ... +100 °C	
Storage temperature	-20 ... +100 °C	
Shock resistance	200 g/6 ms	according to DIN EN 60068-2-27
Vibration resistance	10 g/50 Hz	according to DIN EN 60068-2-6
Shaft	browned steel	
Housing	reinforcing plastic	
Cable sheath	PUR \varnothing 4.8 mm	

Electrical data

Output circuit

Feature	PP, OP Push-pull	LD5 Line driver	LD24 Line driver	Additional information
Operating voltage	+10 ... +30 V DC	+5 V DC ±5 %	+10 ... +30 V DC	
Current consumpt. w/o load (typ.)	<25 mA	<25 mA	<25 mA	AB0 variant
Maximum load/channel	±30 mA	±30 mA	±30 mA	
Max. pulse frequency	100 kHz	100 kHz	100 kHz	
Phasing	90° ±15°	90° ±15°	90° ±15°	
Signal level high (min.)	29.2 V DC			UB = 30 V, IOH = -30 mA
Signal level low (max.)	0.5 V DC			UB = 30 V, IOL = 30 mA
Signal level		RS422 A spec.	RS422 A spec.	
Inverse-polarity protection on UB	yes	no	yes	

Signal image

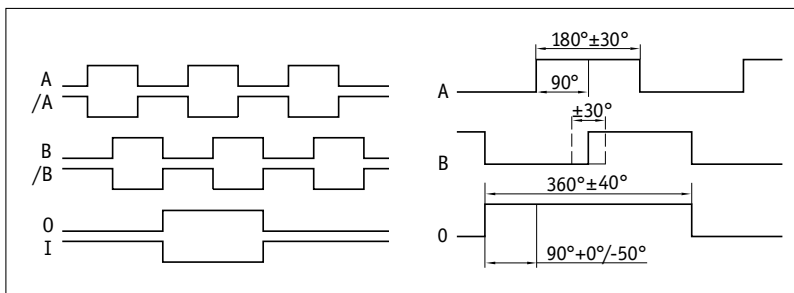

2.1

Pin assignment

Output circuit PP

Signal	E1	E6X
N.C.		A
N.C.		B
O/I	green	C
N.C.		D
A	yellow	E
N.C.		F
N.C.		G
B	white	H
N.C.		J
GND	gray	K
N.C.		L
+UB	brown	M

Output circuit OP, LD5, LD24

Signal	E1	E6X
/B	blue	A
N.C.		B
0	green	C
/0	red	D
A	yellow	E
/A	pink	F
N.C.		G
B	white	H
N.C.		J
GND	gray	K
N.C.		L
+UB	brown	M

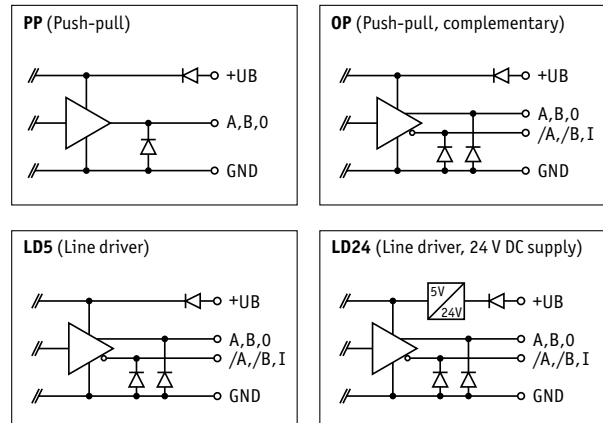

Order

Order table

Feature	Order data	Specification	Additional information
Output signals	... A	ABO, ABI, ABX	
Pulses/revolution	... B	50, 64, 100, 128, 200, 250, 256, 320, 400, 512, 640, 800, 1000, 1024, 1280, 1600, 2000, 2048, 2560 others on request	
Type of connection	E1 E6X C	flying leads connector	
Cable length L (m)	... D	0.3, 0.4, 1, 2, 3, 4, 5, 6, 7, 8, 10, 11, 12, 15, 20	
Output circuit	PP OP LD5 LD24 E	push-pull push-pull with inverted signals line driver line driver	
Shaft design	GW KL F	set screw clamp ring	
Shaft diameter	... G	12, 14, 15, 16, 20	
Ambient condition	S E H	condensation not permitted condensation permitted	
Torque support	A B I	form A, cylindric pin form B, for tolerance compensation	
Protection category	IP53 IP63 K		
Intermediate plate	OZP ZP L	without intermediate plate with intermediate plate	

Order code

IG09M - - - - - - - - - - - -

A B C D E F G H I K L

Scope of delivery: IG09M, User information

Accessories:

Mating connectors

Page 88

Cable extension

Page 90

Electronic displays MA55, MA10/4

Catalog 6 DisplayLine

Additional information:

General information and areas of application

Page 8 cont.