

Profile

- Resolutions of max. 2560 pulses/revolution
- Solid shafts up to $\varnothing 10$ mm, stainless steel
- IP65 protection category
- Aluminum housing
- Condensation permitted with sealed electronics unit

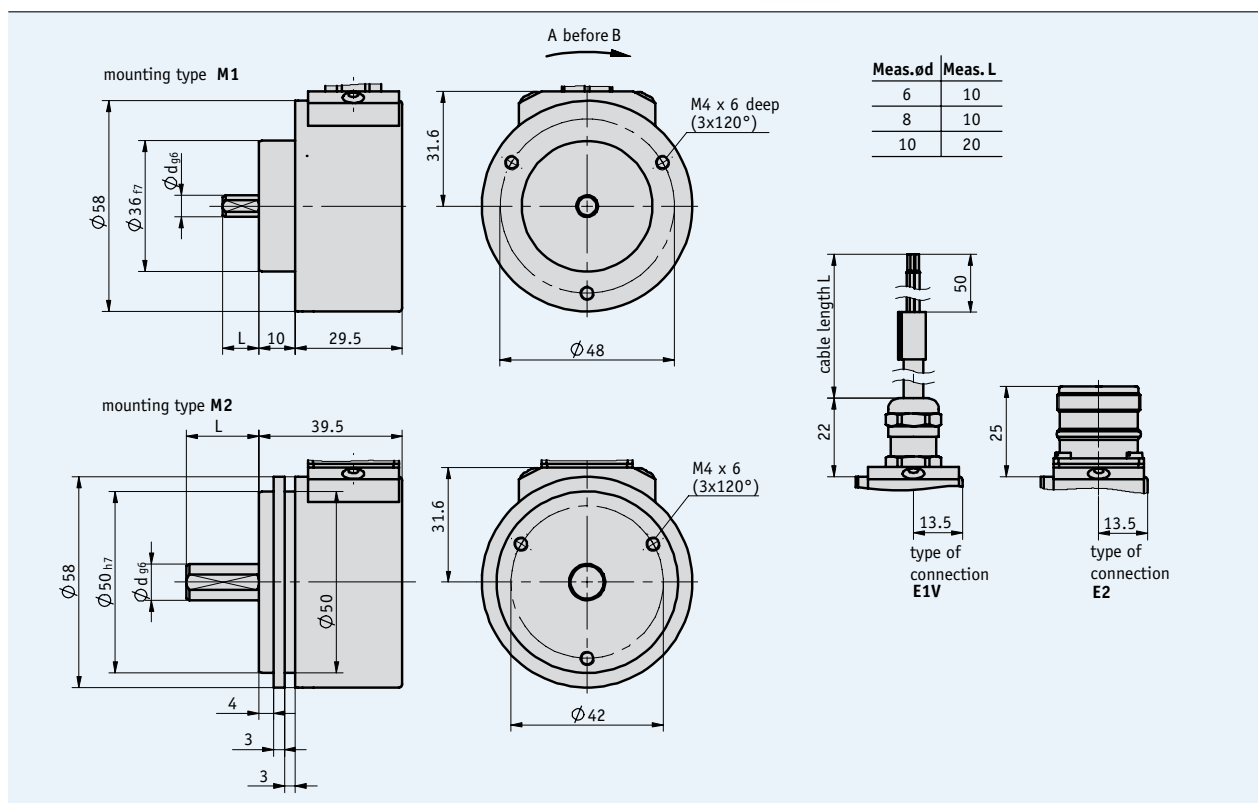

2.1

Mechanical data

Feature	Technical data	Additional information
Max. speed	6000 rpm	
Shaft moment of inertia	$\sim 0.15 \times 10^{-6} \text{ kgm}^2$	
Starting torque	$\leq 1.5 \text{ Ncm}$	at 20 °C
Shaft load rating	radial 80 N axial 40 N	
Weight	$\sim 0.4 \text{ kg}$	
Protection category	IP65	
Operating temperature	-20 ... +100 °C	
Storage temperature	-20 ... +100 °C	
Shock resistance	200 g/6 ms	according to DIN EN 60068-2-27
Vibration resistance	10 g/50 Hz	according to DIN EN 60068-2-6
Shaft	stainless steel	
Housing	aluminum	
Cable sheath	PUR $\varnothing 4.8 \text{ mm}$	

Electrical data

Output circuit

Feature	PP, OP Push-pull	LD5 Line driver	LD24 Line driver	Additional information
Operating voltage	+10 ... +30 V DC	+5 V DC $\pm 5\%$	+10 ... +30 V DC	
Current consumpt. w/o load (typ.)	<25 mA	<25 mA	<25 mA	ABO variant
Maximum load/channel	± 30 mA	± 30 mA	± 30 mA	
Max. pulse frequency	100 kHz	100 kHz	100 kHz	
Phasing	$90^\circ \pm 15^\circ$	$90^\circ \pm 15^\circ$	$90^\circ \pm 15^\circ$	
Signal level high (min.)	29.2 V DC			UB = 30 V, IOH = -30 mA
Signal level low (max.)	0.5 V DC			UB = 30 V, IOL = 30 mA
Signal level		RS422 A spec.	RS422 A spec.	
Inverse-polarity protection on UB	yes	no	yes	

Signal image

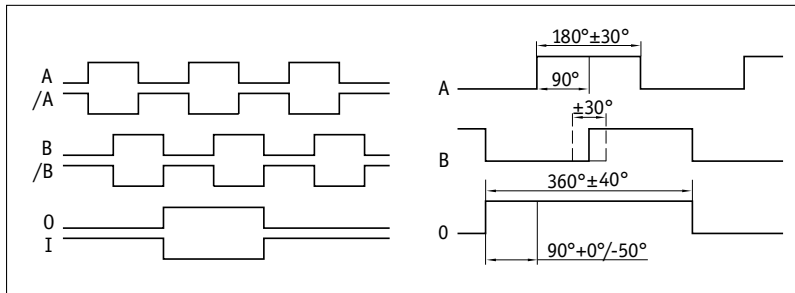

Pin assignment

Output circuit PP

Signal	E1V	E2
N.C.		1
N.C.		2
O/I	green	3
N.C.		4
A	yellow	5
N.C.		6
N.C.		7
B	white	8
N.C.		9
GND	gray	10
N.C.		11
+UB	brown	12

Output circuit LD5

Signal	E1V	E2
/B	blue	1
+SUB	violet	2
0	green	3
/0	red	4
A	yellow	5
/A	pink	6
N.C.		7
B	white	8
N.C.		9
GND	gray	10
SGND	black	11
+UB	brown	12

Output circuit OP, LD24

Signal	E1V	E2
/B	blue	1
N.C.		2
0	green	3
/0	red	4
A	yellow	5
/A	pink	6
N.C.		7
B	white	8
N.C.		9
GND	gray	10
N.C.		11
+UB	brown	12

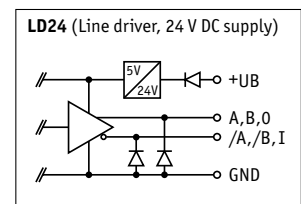
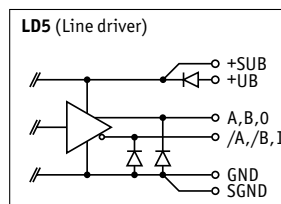
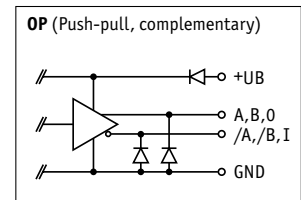
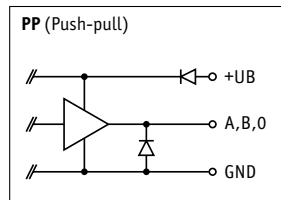

Order

Order table

Feature	Order data	Specification	Additional information
Output signals	... A	ABO, ABI, ABX	
Pulses/revolution	... B	50, 64, 100, 128, 200, 250, 256, 320, 400, 500, 512, 640, 800, 1000, 1024, 1280, 1600, 2000, 2048, 2560 others on request	
Type of connection	E1V E2 C	PG screwing connector	
Cable length L (m)	... OK D	1, 2, 3, 4, 5, 7, 8, 10, 15, 20 without cable	only with E2
Mounting type	M1 M2 E	clamping flange servo-flange	
Output circuit	PP OP LD5 LD24 F	push-pull push-pull with inverted signals line driver line driver	
Shaft diameter	6x10 8x10 10x20 G	∅ 6 mm, length 10 mm ∅ 8 mm, length 10 mm ∅ 10 mm, length 20 mm	
Ambient condition	S E H	condensation not permitted condensation permitted	

Order code

IV58M - - - - - - - -

A B C D E F G H

Scope of delivery: IV58M, User information

Accessories:

Mating connectors Page 88
 Cable extension Page 90
 Self-aligning coupling Page 94
 Servo-clamp Page 95
 Electronic displays MA55, MA10/4 Catalog 6 DisplayLine

Additional information:

General information and areas of application Page 8 cont.