

# Actuator AG01

Compact high-performance actuator in a small-sized housing.  
Fitted for precise and absolute positioning - optionally with an integrated geared potentiometer or with an incremental encoder attached directly on the hollow shaft!



**SIKO GmbH**

**Address**  
Weihermattenweg 2  
79256 Buchenbach

**Telephone**  
+49 7661 394-0

**Fax**  
+49 7661 394-388

**eMail**  
info@siko.de  
**Internet**  
www.siko.de



**Features:**

- easy mounting
- through hollow shaft up to max.  $\varnothing 14\text{mm}$
- high-performance motor 70W, 24VDC or 20W, 48VDC
- various output speeds
- with integrated position transducer: absolut / incremental
- Separate output stage MS02 on request

Feature	Order text	Additional information	
Gear ratio	48	25% ED (duty cycle)	
	24	25% ED (duty cycle)	
	12.4	25% ED (duty cycle)	
Motor Power	70W-M	24VDC	
	70W-G	24VDC	
	20W-M/48V	48VDC	
Shaft type / $\varnothing$ (mm)	KR/14	clamp ring / $\varnothing 14\text{mm}$	
	KR/12	clamp ring / $\varnothing 12\text{mm}$	
	N/10	keyway JS9 DIN 6885/1 / $\varnothing 10\text{mm}$	
Hollow shaft type	S	blind hole	
	D	through hole	
Torque support (form)	A	bolt $\varnothing 6$	
	B	bracket I	
Connection type	E1	stripped cable	
	EX	plug socket on the device	
Cable length motor	2.0	in [m] others on demand	
cable length position transducer	2.0	in [m] others on demand	
Position transducer	LD24	incremental encoder 1024 pulses	supply +10V ... +30V; output circuit RS422
	LD5	incremental encoder 1024 pulses	supply 5VDC $\pm 5\%$ ; output circuit RS422
	OP	push pull with inversion	supply +10V ... +30V; output circuit Push-Pull
	P10	potentiometer 10k $\Omega$	10-filaments potentiometer; others on demand
	MWI	transducer 4 ... 20mA	
	MWU	transducer 0 ... 10V	
	0	without	
Gear ratio of potentiometer	1 ... 128 max.	only with transducer P10, MWI and MWU	
Sense of rotation	i	clockwise increasing values	only with transducer MWI or MWU
	e	counter-clockwise increasing values	only with transducer MWI or MWU

Your ordering:  -  -  -  -  -  -  -  -  -  -  -

## Actuator AG01

### AG01 Drive-Line Selection guide

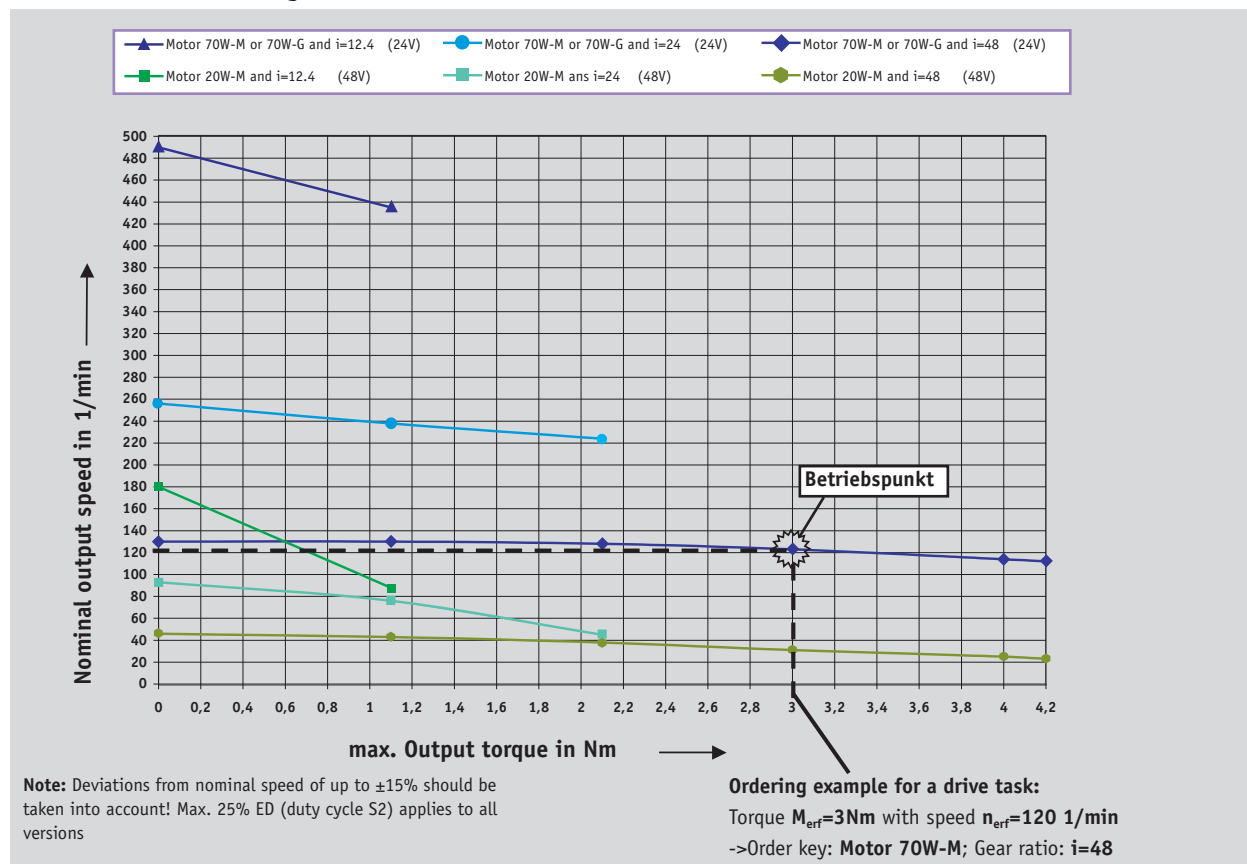

#### Technical Data

##### Mechanical data:

Hollow shaft	Stahl blue
Housing	Aluminium / zinc dye casting

##### Electrical data motor:

Supply voltage	0 ... 24VDC 0 ... 48VDC	70 W-motor 20 W-motor
Power consumption	$P_{20} = 70\text{W}$ resp. $P_{20} = 20\text{W}$	
Rated current	2.9A $\pm 10\%$ (70W-M) 4.1A $\pm 10\%$ (70W-G) 0.4A $\pm 10\%$ (20W-M)	max. loaded current 3.2A max. loaded current 4.5A max. loaded current 0.44A

##### Electrical data encoder:

	LD5	LD24	OP
Supply voltage	5VDC $\pm 5\%$	24VDC $\pm 20\%$	24VDC $\pm 20\%$
Power consumption	$\leq 35\text{mA}$	$\leq 35\text{mA}$	$\leq 35\text{mA}$
Output circuit	Line Driver (RS422)	Line Driver (Rs422)	Push Pull (OP)
Output signals	A, B, 0, $\bar{A}$ , $\bar{B}$ , I	A, B, 0, $\bar{A}$ , $\bar{B}$ , I	A, B, 0, $\bar{A}$ , $\bar{B}$ , I

##### Electrical data potentiometer:

Resistance tolerance	$\pm 5\%$
Linearity tolerance	$\pm 0.25\%$
Load capacity	2W at 40°C
Standard residual end point resistance deviation	0.5% or 1Ω

(whichever value is higher)

##### Environmental conditions:

Operating temperature (condensation not permitted)	0° ... +70°C
Operating mode	short-time operation S2 (25%ED)
Certification / protection class	CE-conformant
Protection	IP63

acc. to DIN 57530 / VDE 0530 Part 1  
acc. to EN 61000-6-2 and EN 61000-6-4  
acc. to DIN VDE 0470

##### Accessory:

82247	Mating connector for motor	4 pins, angle cableconnector
81351	Mating connector for encoder	8 pins, circular cableconnector
81487	Mating connector for potentiometer	3 pins, circular cableconnector
KV04-0	cable extension motor	
KV08-0	Cable extension encoder	
KV03-0	Cable extension potentiometer	

#### Additional information

# Actuator AG01

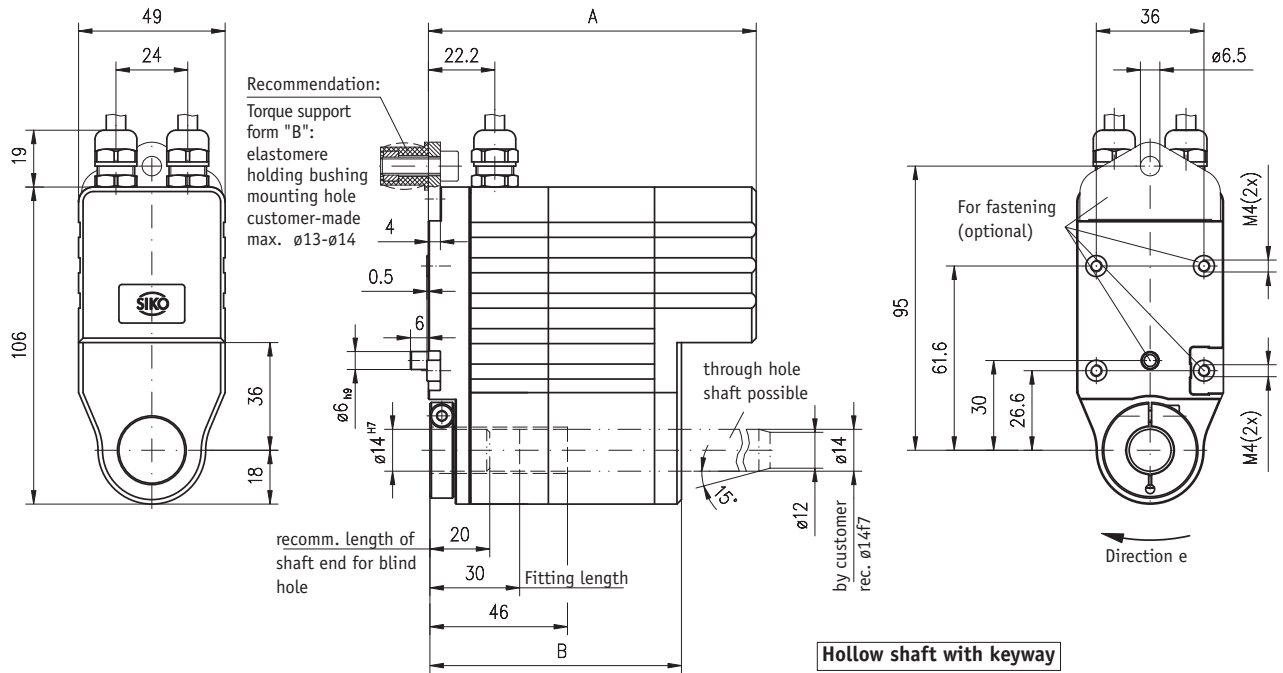

motor / encoder	length A	length B
Motor 70W-M	110	84
Motor 20W-M		
Motor 70W-M +potentiometer	125	100
Motor 70W-G	134	109

### Hollow shaft with keyway

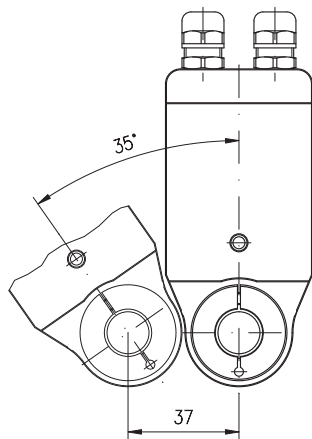
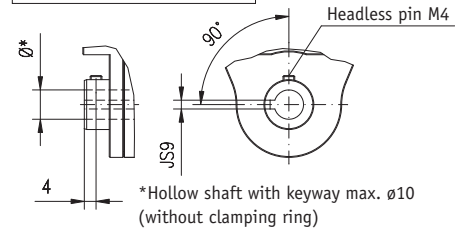

### Connection type EX

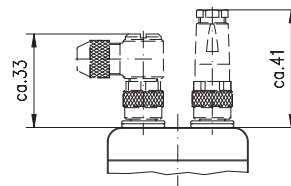

### Connection type E1

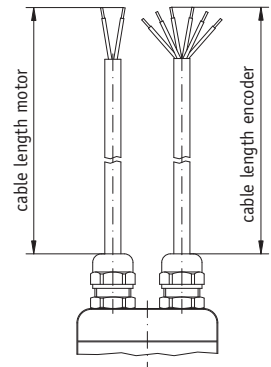

### Pin connection E1, EX

#### Motor (4-pol.)

colour	signal	PIN
M1 (white printed)	+	1
		2
M2 (white printed)	-	3
		4

#### Encoder (8-pol.)

##### encoder (8-pol.)

colour	signal	PIN
white	B	1
brown	+UB	2
green	0	3
yellow	A	4
grey	GND	5
pink	/A	6
blue	/B	7
red	I	8

#### Potentiometer (3-pol.)

##### (without transducer)

colour	signal	PIN
brown	Po	1
green	S	2
white	Pe	3

##### (with transducer MWU)

colour	signal	PIN
brown	+24VDC	1
green	$U_{out}$	2
whit	GND	3

##### (with transducer MWI)

colour	signal	PIN
brown	I+	1
white	I-	3

# Actuator AG01

Notes: