

Power Supplies

Power Supplies

The CLICK PLC family offers two 24 VDC power supplies. They are identical except for the output current.

It is not mandatory to use one of these CLICK power supplies for the CLICK PLC system. You can use any other 24 VDC power supply that Automationdirect.com offers.

CO-00AC Power Supply

Limited auxiliary AC power supply allows you to power the 24 VDC CLICK C0 series CPUs with 100-240 VAC supply power. The 0.5A DC power supply is capable of controlling the CPU plus a limited configuration based on the power budget of each I/O module. The CO-00AC is a low-cost solution for applications requiring only minimal I/O and power consumption. This power supply will not support a fully-populated CLICK PLC system with all possible I/O module combinations.

CO-01AC Power Supply

Expanded auxiliary AC power supply allows you to power the 24 VDC CLICK C0 series CPUs with 100-240 VAC supply power. The 1.3A DC power supply is capable of supporting a fully-populated CLICK PLC system with all possible I/O module combinations, with no concerns for exceeding the power budget.

CLICK 24 VDC Power Supply Ratings	
Part Number	Output Current
CO-00AC	0.5 A
CO-01AC	1.3 A

CO-00AC Power Supply Specifications	
Input Voltage Range	85-264 VAC
Input Frequency	47-63 Hz.
Input Current (typical)	0.3 A @ 100 VAC, 0.2 A @ 200 VAC
Inrush Current	30 A
Output Voltage Range	23-25 VDC
Output Current	0.5 A
Over Current Protection	@ 0.65 A (automatic recovery)
Weight	5.3 oz (150g)

CO-01AC Power Supply Specification	
Input Voltage Range	85-264 VAC
Input Frequency	47-63 Hz.
Input Current (typical)	0.9 A @ 100 VAC, 0.6 A @ 200 VAC
Inrush Current	30 A
Output Voltage Range	23-25 VDC
Output Current	1.3 A
Over Current Protection	@ 1.6 A (automatic recovery)
Weight	6.0 oz (170g)

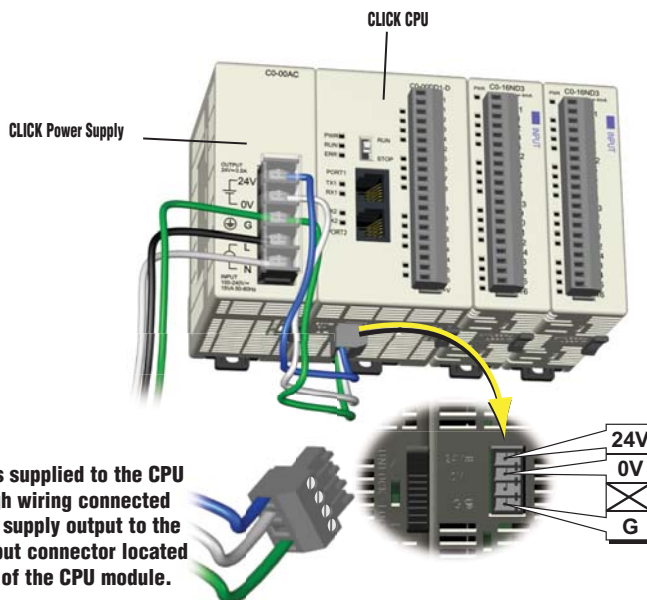
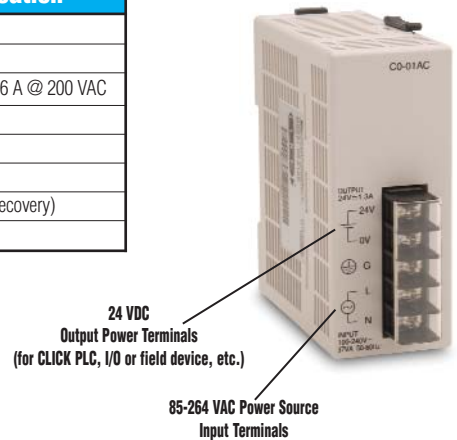
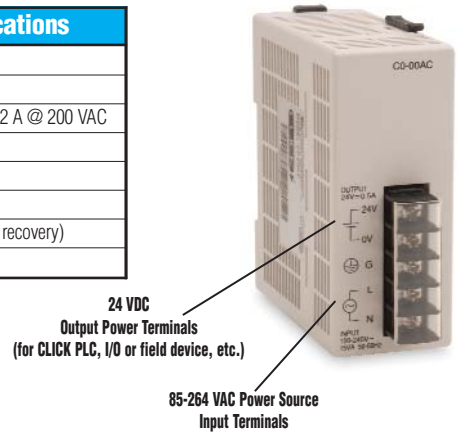

Power Budgeting

Power Budgeting

There are two areas to be considered when determining the power required to operate a CLICK PLC system. The first area is the power required by the CLICK CPU, along with the internal logic side power that the CPU provides to its own I/O and any connected I/O modules that are powered through the CPU's expansion port; plus any device, such as a C-more Micro-Graphic panel, that is powered through one of the CPU's communication ports.

The second area is the power required by all externally connected I/O devices. This should be viewed as the field side power required. The field side power is dependent on the voltage used for a particular input or output device as it relates to the wired I/O point, and the calculated load rating of the connected device.

It is strongly recommended that the power source for the logic side be separate from the power source for the field side to help eliminate possible electrical noise.

Power budgeting requires the calculation of the total current that the 24 VDC power source needs to provide to CLICK's logic side, and also a separate calculation of the total current required for all devices operating from the field side of the PLC system.

See the Power Budgeting Example shown to the right. The table shows current requirements for a CLICK CPU, two I/O modules, and a C-more Micro. Use the total amperage values to select a proper sized power supply.

Power Budgeting Using the CLICK Programming Software

The following example shows the logic side current consumption as calculated in the CLICK Programming software. Based on the amperage rating of the power supply selected in the first column, your power budget is calculated by subtracting each consecutive module's power consumption from the total available power budget. If you exceed the maximum allowable power consumption the power budget row is highlighted in red.

Power budget row turns red if maximum allowable power consumption is exceeded for the power supply selected.



CLICK 24 VDC Power Supply
CO-00AC or CO-01AC



Other 24 VDC Power Supply
Example: PSP24-60S

Current Consumption (mA)		
Part Number	Power Budget 24 VDC (logic side)	External 24 VDC (field side)
Basic CPU Modules		
CO-00DD1-D	120	60
CO-00DD2-D	120	0
CO-00DR-D	120	0
CO-00AR-D	120	0
Analog CPU Modules		
CO-02DD1-D	120	60
CO-02DD2-D	120	0
CO-02DR-D	120	0
Input Modules		
CO-08ND3	30	0
CO-08ND3-1	30	0
CO-16ND3	40	0
CO-08NA	30	0

Current Consumption (mA)		
Part Number	Power Budget 24 VDC (logic side)	External 24 VDC (field side)
Output Modules		
CO-08TD1	50	15
CO-08TD2	50	0
CO-16TD1	80	100
CO-16TD2	80	0
CO-08TA	80	0
CO-04TRS	100	0
CO-08TR	100	0
C-more Micro-Graphic Panel		
All p/n	90	0

Power Budgeting Example

Current Consumption (mA) Example		
Part Number	Power Budget 24 VDC (logic side)	External 24 VDC (field side)
CO-00DD1-D	120	60
CO-16ND3	40	0
CO-16TD1	80	100
C-more Micro	90	0
Total:	330	160 *

* Plus calculated load of connected I/O devices.

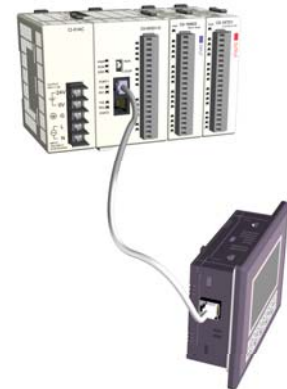

The screenshot shows the 'System Configuration Setup' window with a rack of modules including P/S, CPU, and various I/O modules. Below the rack is a table with the following data:

Name	P/S	CPU	I/O 1	I/O 2	I/O 3	I/O 4	I/O 5	I/O 6	I/O 7	I/O 8
Module Type	CO-00AC	CO-00DR-D	CO-16ND3	CO-08ND3	CO-08NA	CO-16TD1	CO-04TRS	CO-08TR		
Input		X001-X008	X101-X116	X201-X208	X301-X308					
Output		Y001-Y006				Y401-Y416	Y501-Y504	Y601-Y608		
PwrBudget(mA)	520	120	40	30	30	80	100	120		

The 'PwrBudget(mA)' row is highlighted in red, indicating that the total power consumption (330 mA) exceeds the available power budget (520 mA).