

Relay Output Modules

D2-04TRS Relay Output <--->	
Outputs per Module	4
Outputs Points Consumed	8 (only 1st 4pts. are used)
Commons per Module	4 (isolated)
Output Type	Relay, form A (SPST)
Operating Voltage	5-30 VDC / 5-240 VAC
Peak Voltage	30 VDC, 264 VAC
ON Voltage Drop	0.72 VDC maximum
AC Frequency	47 to 63 Hz
Minimum Load Current	10 mA
Max Load Current (resistive)	4A/point; 8A/module (resistive)
Max Leakage Current	0.1 mA @ 264 VAC
Max Inrush Current	5A for < 10 ms
Base Power Required 5VDC	250 mA
OFF to ON Response	10 ms
ON to OFF Response	10 ms
Terminal Type (included)	Removable; D2-8IOCON
Status Indicator	Logic side
Weight	2.8 oz. (80 g)
Fuses	1 per point 6.3A slow blow, replaceable Order D2-FUSE-3 (5 per pack)

Typical Relay Life (Operations)				
Voltage & Load Current				
Type of Load	1A	2A	3A	4A
24 VDC Resistive	500k	200k	100k	50k
24 VDC Solenoid	100k	40k	—	—
110 VAC Resistive	500k	250k	150k	100k
110 VAC Solenoid	200k	100k	50k	—
220 VAC Resistive	350k	150k	100k	50k
220 VAC Solenoid	100k	50k	—	—

At 24 VDC, solenoid (inductive) loads over 2A cannot be used.
At 100 VAC, solenoid (inductive) loads over 3A cannot be used.
At 220 VAC, solenoid (inductive) loads over 2A cannot be used.



See page 4-78 for part numbers of ZIPLink cables and connection modules compatible with this I/O module.

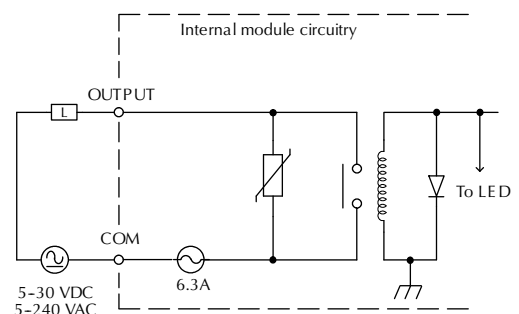
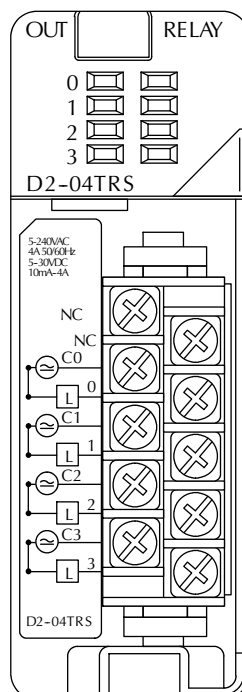
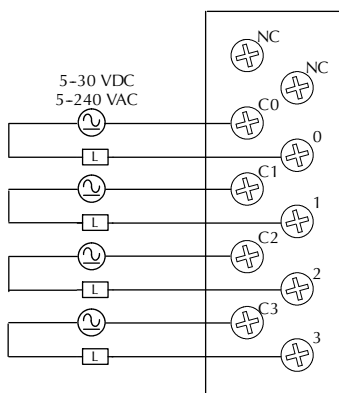
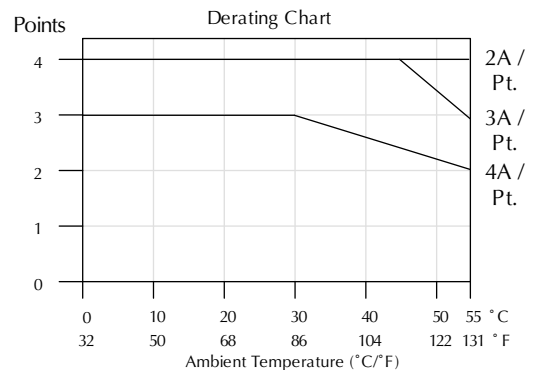

Relay Output Modules

D2-08TR Relay Output <---->	
Outputs per Module	8
Outputs Points Consumed	8
Commons per Module	1 (2 I/O terminals)
Output Type	Relay, form A (SPST)
Operating Voltage	5-30 VDC; 5-240 VAC
Peak Voltage	30 VDC, 264 VAC
ON Voltage Drop	N/A
AC Frequency	47 to 60 Hz
Minimum Load Current	5mA @ 5VDC
Max Load Current (resistive)	1A/point; 4A/common
Max Leakage Current	0.1 mA @265 VAC
Max Inrush Current	Output: 3A for 10 ms Common: 10A for 10 ms
Base Power Required 5VDC	250 mA
OFF to ON Response	12 ms
ON to OFF Response	10 ms
Terminal Type (included)	Removable; D2-8IOCON
Status Indicator	Logic side
Weight	3.9 oz. (110g)
Fuses	One 6.3A slow blow, replaceable Order D2-FUSE-3 (5 per pack)

Typical Relay Life (Operations)		
Voltage/Load	Current	Closures
24 VDC Resistive	1A	500k
24 VDC Solenoid	1A	100k
120 VDC Resistive	1A	500k
120 VDC Solenoid	1A	200k
220 VAC Resistive	1A	350k
220 VAC Solenoid	1A	100k

See page 4-78 for part numbers of ZIPLink cables and connection modules compatible with this I/O module.

Note: When used with the ZIPLink wiring system, relay outputs are derated not to exceed 2 Amps per point max.

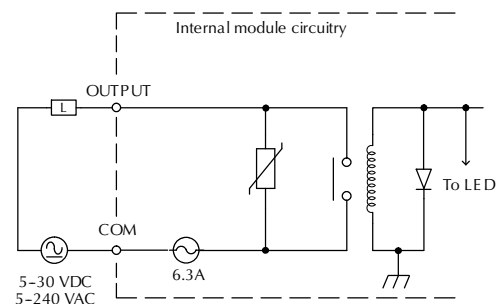
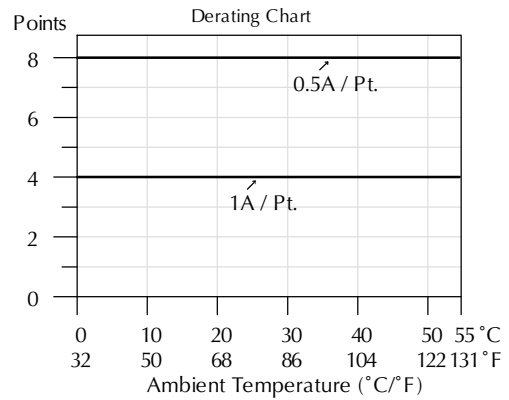
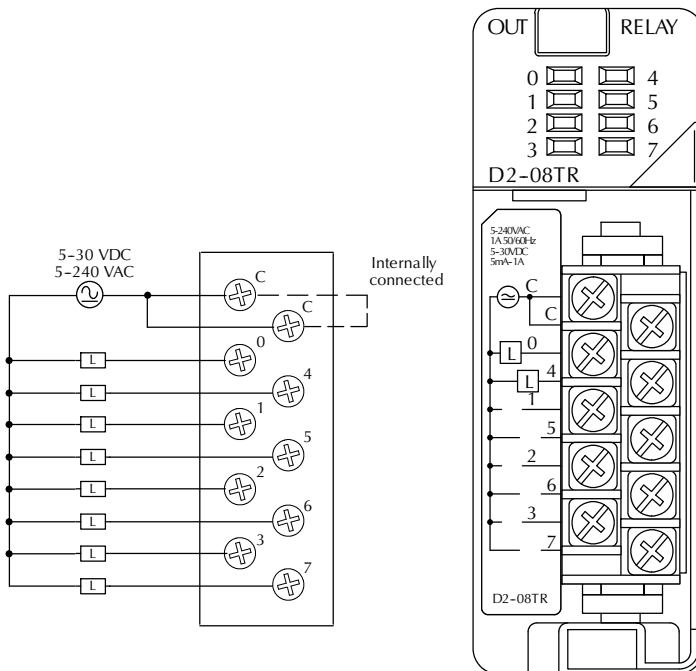

Relay Output Modules

F2-08TRS Relay Output <--->	
Outputs per Module	8
Outputs Points Consumed	8
Commons per Module	8 (isolated)
Output Type	3, Form C (SPDT) 5, Form A (SPST normally open)
Operating Voltage	7A @ 12-28 VDC, 12-250 VAC 0.5A @ 120VDC
Peak Voltage	150 VDC, 265 VAC
ON Voltage Drop	N/A
AC Frequency	47 to 63Hz
Minimum Load Current	10mA @ 12 VDC
Max Load Current (resistive)	7A/point ³ (subject to derating)
Max Leakage Current	N/A
Max Inrush Current	12A
Base Power Required 5VDC	670 mA
OFF to ON Response	15 ms (typical)
ON to OFF Response	5ms (typical)
Terminal Type (included)	Removable; D2-16IOCON
Status Indicator	Logic side
Weight	5.5oz. (156g)
Fuses	None



See page 4-78 for part numbers of ZIPLink cables and connection modules compatible with this I/O module.

Typical Relay Life ¹ (Operations) at Room Temperature			
Voltage & Type of Load ²	Load Current		
	50mA	5A	7A
24 VDC Resistive	10M	600k	300k
24 VDC Solenoid	-	150k	75k
120 VDC Resistive	-	600k	300k
120 VDC Solenoid	-	500k	200k
220 VAC Resistive	-	300k	150k
220 VAC Solenoid	-	250k	100k

1) Contact life may be extended beyond those values shown with the use of arc suppression techniques described in the DL205 User Manual. Since these modules have no leakage current, they do not have built-in snubber. For example, if you place a diode across a 24 VDC inductive load, you can significantly increase the life of the relay.

2) At 120 VDC 0.5A resistive load, contact life cycle is 200k cycles.

3) Normally closed contacts have 1/2 the current handling capability of the normally open contacts.

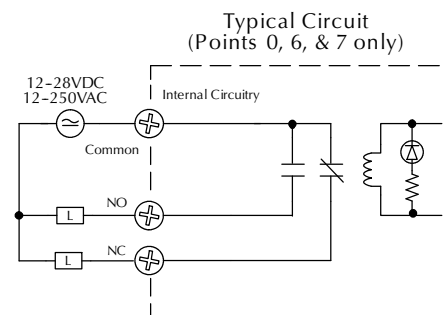
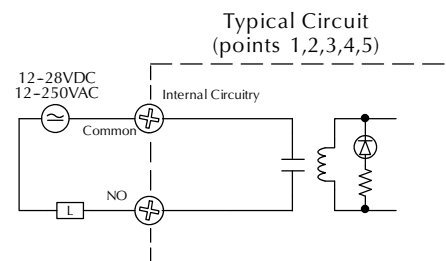
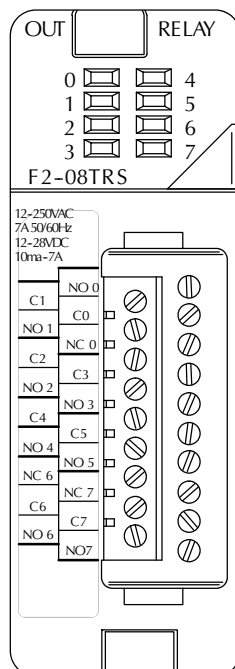
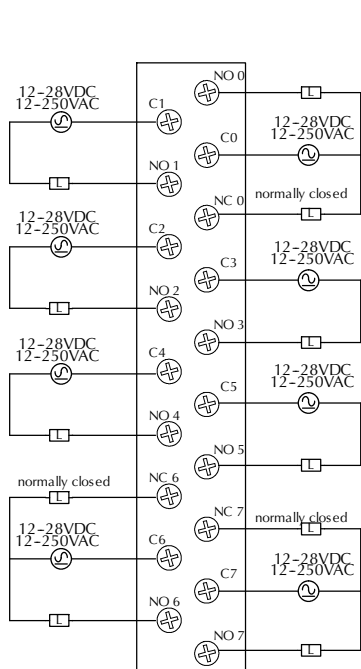
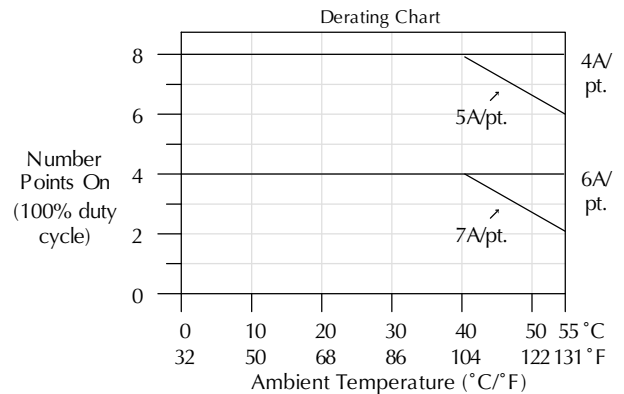

Relay Output Modules

F2-08TR Relay Output <--->	
Outputs per Module	8
Outputs Points Consumed	8
Commons per Module	2 (isolated), 4-pts. per common
Output Type	8, Form A (SPST normally open)
Operating Voltage	7A @ 12-28 VDC, 12-250VAC; 0.5A @ 120 VDC
Peak Voltage	150 VDC, 265 VAC
ON Voltage Drop	N/A
AC Frequency	47 to 63Hz
Minimum Load Current	10 mA @ 12 VDC
Max Load Current (resistive)	10A/point ³ (subject to derating) Max of 10A/common
Max Leakage Current	N/A
Max Inrush Current	12A
Base Power Required 5VDC	670 mA
OFF to ON Response	15 ms (typical)
ON to OFF Response	5ms (typical)
Terminal Type (included)	Removable; D2-8IOCON
Status Indicator	Logic side
Weight	5.5 oz. (156g)
Fuses	None

See page 4-78 for part numbers of ZIPLink cables and connection modules compatible with this I/O module.

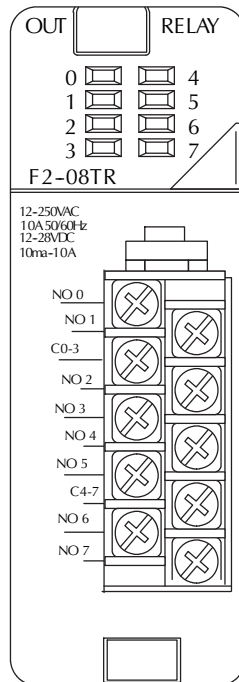
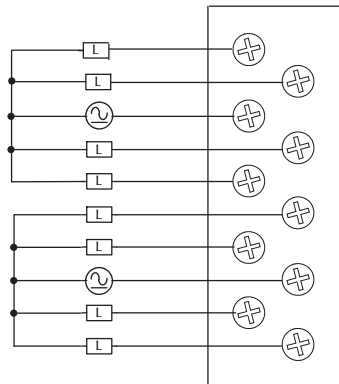

Typical Relay Life ¹ (Operations) at Room Temperature			
Voltage & Type of Load ²	Load Current		
	50 mA	5A	7A
24 VDC Resistive	10M	600k	300k
24 VDC Solenoid	-	150k	75k
110 VDC Resistive	-	600k	300k
110 VDC Solenoid	-	500k	200k
220 VAC Resistive	-	300k	150k
220 VAC Solenoid	-	250k	100k

1) Contact life may be extended beyond those values shown with the use of arc suppression techniques described in the DL205 User Manual. Since these modules have no leakage current, they do not have built-in snubber. For example, if you place a diode across a 24 VDC inductive load, you can significantly increase the life of the relay.
2) At 120 VDC 0.5A resistive load, contact life cycle is 200k cycles.
3) Normally closed contacts have 1/2 the current handling capability of the normally open contacts.

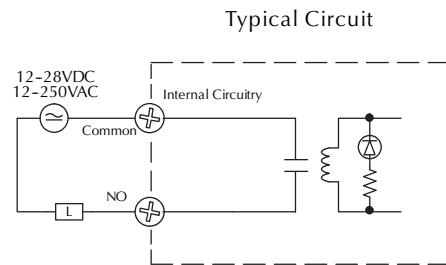
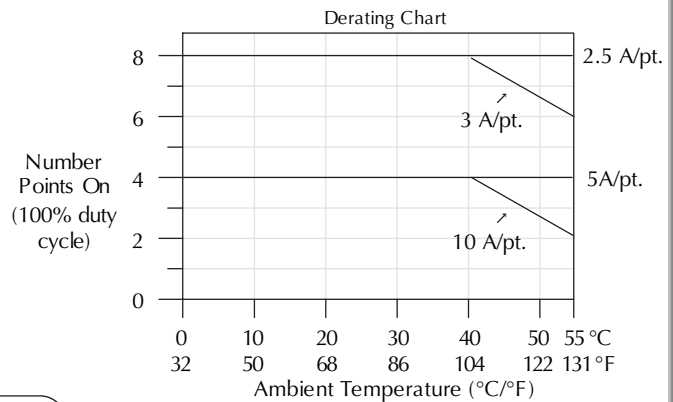

Relay Output Modules

D2-12TR Relay Output <---->	
Outputs per Module	12
Outputs Points Consumed	16 (four unused, see chart below)
Commons per Module	2 (6-pt. per common)
Output Type	Relay, form A (SPST)
Operating Voltage	5-30 VDC; 5-240 VAC
Peak Voltage	30 VDC; 264 VAC
ON Voltage Drop	N/A
AC Frequency	47 to 60 Hz
Minimum Load Current	5mA @ 5VDC
Max Load Current (resistive)	1.5 A/point; Max of 3A/common
Max Leakage Current	0.1 mA @ 265 VAC
Max Inrush Current	Output: 3A for 10ms Common: 10A for 10ms
Base Power Required 5VDC	450 mA
OFF to ON Response	10 ms
ON to OFF Response	10 ms
Terminal Type (included)	Removable; D2-16IOCON
Status Indicator	Logic side
Weight	4.6 oz. (130g)
Fuses	(2) 4A slow blow, replaceable Order D2-FUSE-4 (5 per pack)

Typical Relay Life (Operations)		
Voltage/Load	Current	Closures
24 VDC Resistive	1A	500k
24 VDC Solenoid	1A	100k
110 VDC Resistive	1A	500k
110 VDC Solenoid	1A	200k
220 VAC Resistive	1A	350k
220 VAC Solenoid	1A	100k

Addresses Used			
Points	Used?	Points	Used?
Yn+0	Yes	Yn+10	Yes
Yn+1	Yes	Yn+11	Yes
Yn+2	Yes	Yn+12	Yes
Yn+3	Yes	Yn+13	Yes
Yn+4	Yes	Yn+14	Yes
Yn+5	Yes	Yn+15	Yes
Yn+6	No	Yn+16	No
Yn+7	No	Yn+17	No

n is the starting address

See page 4-78 for part numbers of ZIPLink cables and connection modules compatible with this I/O module.

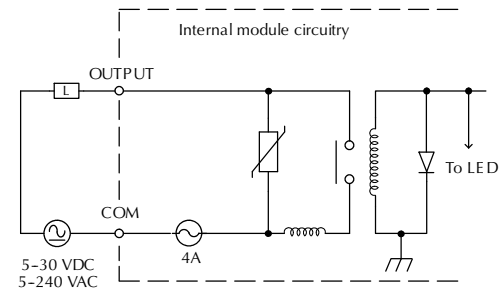
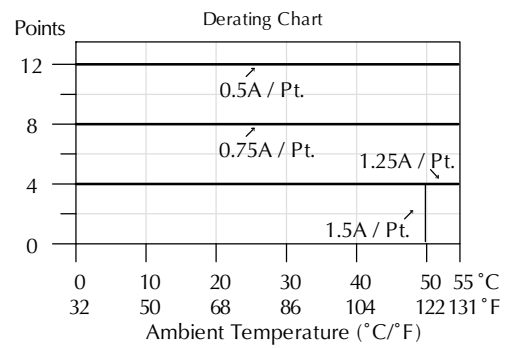
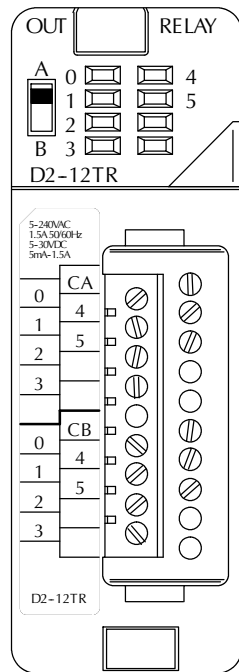
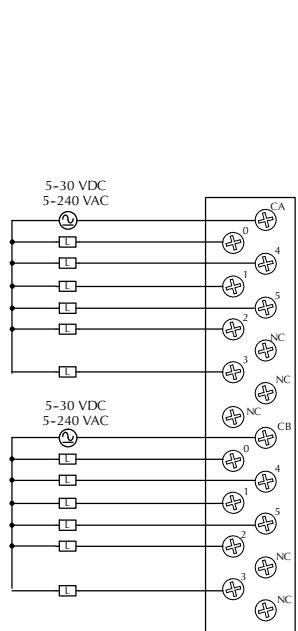

DC Input/Relay Output Module

D2-08CDR 4-pt. DC In / 4pt. Relay Out <--->	
General Specifications	
Base Power Required 5VDC	200 mA
Terminal Type (included)	Removable; D2-8IOCON
Status Indicator	Logic side
Weight	3.5 oz. (100 g)
Input Specifications	
Inputs per Module	4 (sink/source)
Input Points Consumed	8 (only first 4-pts. are used)
Commons per Module	1
Input Voltage Range	20-28 VDC
Peak Voltage	30 VDC
ON Voltage Level	19 VDC minimum
OFF Voltage Level	7 VDC maximum
AC Frequency	N/A
Input Impedance	4.7 kΩ
Input Current	5mA @ 24 VDC
Maximum Current	8mA @ 30 VDC
Minimum ON Current	4.5 mA
Maximum OFF Current	1.5 mA
OFF to ON Response	1 to 10 ms
ON to OFF Response	1 to 10 ms
Fuses (input circuits)	None

Output Specifications	
Outputs per Module	4
Outputs Points Consumed	8 (only first 4-pts. are used)
Commons per Module	1
Output Type	Relay, form A (SPST)
Operating Voltage	5-30 VDC; 5-240 VAC
Peak Voltage	30 VDC; 264 VAC
ON Voltage Drop	N/A
AC Frequency	47 to 63 Hz
Minimum Load Current	5 mA @ 5 VDC
Max Load Current (resistive)	1A/point ; 4A/module
Max Leakage Current	0.1 mA @ 264 VAC
Max Inrush Current	3A for < 100 ms 10 A for < 10 ms (common)
OFF to ON Response	12 ms
ON to OFF Response	10 ms
Fuses (output circuits)	1 (6.3A slow blow, replaceable); Order D2-FUSE-3 (5 per pack)

See page 4-78 for part numbers of **ZIPLink** cables and connection modules compatible with this I/O module.



Typical Relay Life (Operations)		
Voltage/Load	Current	Closures
24 VDC Resistive	1A	500k
24 VDC Solenoid	1A	100k
110 VAC Resistive	1A	500k
110 VAC Solenoid	1A	200k
220 VAC Resistive	1A	350k
220 VAC Solenoid	1A	100k

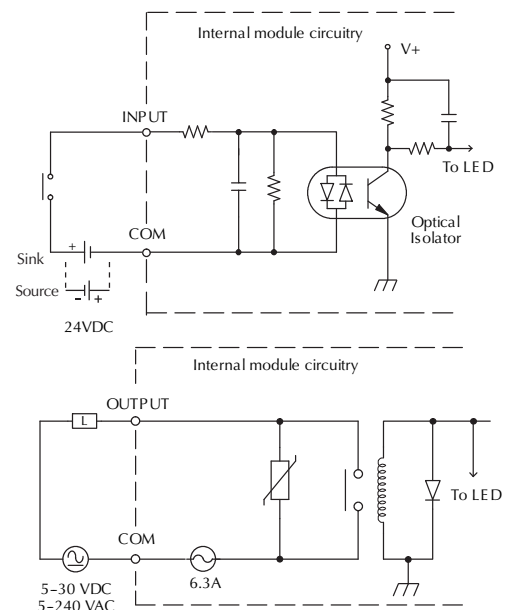
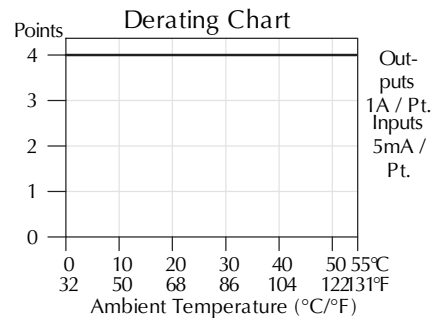
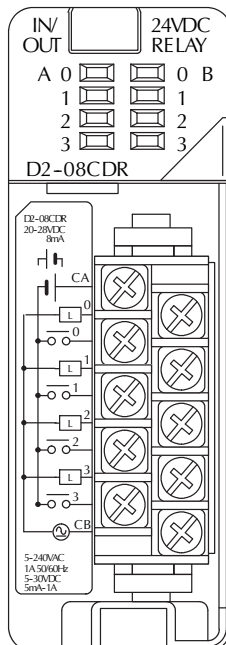
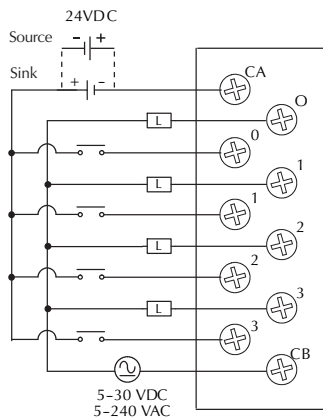

For "Sinking and Sourcing Concepts", see the Appendix section in this catalog.

Cut PLC wiring time to minutes instead of hours

The ZIPLink wiring system eliminates the normally tedious process of wiring PLC I/O to terminal blocks. Simply plug one end of a ZIPLink pre-wired terminal block cable into your I/O module and the other end into a ZIPLink connector module. It's that easy. ZIPLinks use half the space, at a fraction of the total cost of terminal blocks.

ZIPLinks are available in a variety of styles to suit your needs, including fused, relay and sensor/LED connector modules. ZIPLinks are available for all DL205 Series PLC discrete and analog input and output modules.

For complete information see ZIPLinks in the Terminal Blocks and Wiring Solutions section.



Specify your ZIPLink system

Use the Compatibility Matrix table below:

Step 1	Locate the I/O module part number.
Step 2	Locate Connector Module Type. (Feedthrough Module, Fuse Module, etc...)
Step 3	Select the cable length by replacing the # symbol with: Blank = 0.5m, -1 = 1.0m, -2 = 2.0m ¹
¹ Note: Cable part number denotes compatibility between Connector Module and I/O Modules.	

ZIPLink Wiring System Compatibility Matrix for DL205 PLCs									
Step 2: Connector Module Type		Feedthrough Modules		Fuse Modules		Relay Modules	Sensor Input Modules		Pigtail Cable
Step 1: I/O Module	Number of Terminals	ZL-RTB20	ZL-RTB40	ZL-RFU20	ZL-RFU40	ZL-RRL16-24	ZL-LTB16-24	ZL-LTB32-24	
Step 3: Cables									
Inputs									
D2-08ND3	10	ZL-D2-CBL10#							
D2-16ND3-2	19	ZL-D2-CBL19#					ZL-D2-CBL19#		ZL-D2-CBL19#P
D2-32ND3	40		ZL-D24-CBL40#					ZL-D24-CBL40#	ZL-D24-CBL40#P
D2-32ND3-2	40		ZL-D24-CBL40#					ZL-D24-CBL40#	ZL-D24-CBL40#P
D2-08NA-1	10	ZL-D2-CBL10#							
D2-08NA-2	10	ZL-D2-CBL10#							
D2-16NA	19	ZL-D2-CBL19#							ZL-D2-CBL19#P
Outputs									
D2-04TD1*	10	ZL-D2-CBL10#							
D2-08TD1	10	ZL-D2-CBL10#							
D2-08TD2	10	ZL-D2-CBL10#							
D2-16TD1-2	19	ZL-D2-CBL19#		ZL-D2-CBL19#		ZL-D2-CBL19#			ZL-D2-CBL19#P
D2-16TD2-2	19	ZL-D2-CBL19#		ZL-D2-CBL19#					ZL-D2-CBL19#P
D2-32TD1	40		ZL-D24-CBL40#		ZL-D24-CBL40#				ZL-D24-CBL40#P
D2-32TD2	40		ZL-D24-CBL40#		ZL-D24-CBL40#				ZL-D24-CBL40#P
D2-08TA	10	ZL-D2-CBL10#							
F2-08TA	10	ZL-D2-CBL10#							
D2-12TA	19	ZL-D2-CBL19#		ZL-D2-CBL19#					ZL-D2-CBL19#P
D2-04TRS*	10	ZL-D2-CBL10#							
D2-08TR	10	ZL-D2-CBL10#							
F2-08TRS*	19	ZL-D2-CBL19#							ZL-D2-CBL19#P
F2-08TR**	10	ZL-D2-CBL10#							
D2-12TR	19	ZL-D2-CBL19#		ZL-D2-CBL19#					ZL-D2-CBL19#P
Combo In/Out									
D2-08CDR	10	ZL-D2-CBL10#							

*Caution: The D2-04TD1, D2-04TRS, and F2-08TRS outputs are derated not to exceed 2 Amps per point and 2 Amps per common when used with the ZIPLink wiring system.

**The F2-08TR outputs are derated not to exceed 2 Amps per point and 4 Amps per common when used with the ZIPLink wiring system.

ZIPLink Connector Module and Cable specifications found in Terminal Blocks and Wiring Section

Power Requirements

These charts help determine your power requirements

This section shows the amount of power supplied by each of the base power supplies and the amount of power consumed by each DL205 device. The Power Consumed charts list how much INTERNAL power from each power source is required for the DL205 devices. Use this information when calculating the power budget for your system.

In addition to the internal power sources, the DL205 bases offer a 24 VDC auxiliary power supply with external power connections. This auxiliary power supply can power external devices.

Use ZIPLinks to reduce power requirements

If your application requires a lot of relay outputs, consider using the ZIPLink AC or DC relay output modules. These modules can switch high current (10A) loads without putting a load on your base power budget. Refer to the Terminal Blocks and Wiring Solutions section in this catalog for more information.

This logo is placed next to the I/O modules that are supported by the ZIPLink connection systems. See the I/O module specifications at the end of this section.



Power Consumed		
Device	5V(mA)	24V Auxiliary
Operator Interface		
DV-1000	150	0
C-more Micro-Graphic	210	0

Power Supplied							
Device	Price	5V(mA)	24V Auxiliary	Device	Price	5V(mA)	24V Auxiliary
Bases				Bases			
D2-03B-1	<--->	2600	300	D2-06BDC1-1	<--->	2600	None
D2-03BDC1-1	<--->	2600	None	D2-06BDC2-1	<--->	2600	300
D2-04B-1	<--->	2600	300	D2-09B-1	<--->	2600	300
D2-04BDC1-1	<--->	2600	None	D2-09BDC1-1	<--->	2600	None
D2-06B-1	<--->	2600	300	D2-09BDC2-1	<--->	2600	300

Power Consumed		
Device	5V(mA)	24V Auxiliary
CPUs		
D2-230	120	0
D2-240	120	0
D2-250-1	330	0
D2-260	330	0
H2-WPLC**	680	0
DC Input Modules		
D2-08ND3	50	0
D2-16ND3-2	100	0
D2-32ND3	25	0
D2-32ND3-2	25	0
AC Input Modules		
D2-08NA-1	50	0
D2-08NA-2	100	0
D2-16NA	100	0
Input Simulator Module		
F2-08SIM	50	0
DC Output Modules		
D2-04TD1	60	20
D2-08TD1	100	0
D2-08TD2	100	0
D2-16TD1-2	200	80
D2-16TD2-2	200	0
F2-16TD1P	70	50
F2-16TD2P	70	50
D2-32TD1	350	0
D2-32TD2	350	0
AC Output Modules		
D2-08TA	250	0
F2-08TA	250	0
D2-12TA	350	0
Relay Output Modules		
D2-04TRS	250	0
D2-08TR	250	0
F2-08TR(S)	670	0
D2-12TR	450	0
Combination In/Out Module		
D2-08CDR	200	0

Power Consumed		
Device	5V(mA)	24V Auxiliary
Analog Modules		
F2-04AD-1	100	5
F2-04AD-2	110	5
F2-08AD-1	100	5
F2-08AD-2	100	5
F2-02DA-1	40	60 (note 1)
F2-02DA-1L	40	70 @ 12V (note 1)
F2-02DA-2	40	60
F2-02DA-2L	40	70 @ 12V
F2-02DAS-1	100	50 / channel
F2-02DAS-2	100	60 / channel
F2-08DA-1	30	50 (note 1)
F2-08DA-2	60	140
F2-4AD2DA	60	80 (note 1)
F2-8AD4DA-1	35	100 (note 1)
F2-8AD4DA-2	35	80 (note 1)
F2-04RTD	90	0
F2-04THM	110	60
Specialty Modules		
D2-CTRINT	50*	0
D2-CM / D2-EM	100/130	0
H2-CTRIO	400	0
D2-DCM	300	0
F2-DEVNETS	160	0
F2-SDS-1	160	0
H2-PBC	530	0
H2-EBC(-F)	450, (640)	0
H2-ECOM(-F)	450, (640)	0
H2-ECOM100	300	0
F2-CP128	235	0
Remote I/O		
H2-ERM(-F)	320, (450)	0
D2-RMSM	200	0
D2-RSSS	150	0
Programming Devices		
D2-HPP	200	0

*requires external 5VDC for outputs
Note 1: Add an additional 20 mA per output loop.