

DL405 CPU Comparisons

DL405 CPU Specifications			
	D4-430	D4-440	D4-450
System Capacity			
Total memory available (words)	6.5K	22.5K	30.8K
Ladder memory (words)			
built-in memory	3.5K EEPROM	None, requires MC	7.5K flash
with memory cartridge	N/A	up to 15.5K	up to 15.5K
V-memory (words)	3.0K	7.0K	15.3K
Battery backup	Yes	Yes	Yes
Total CPU memory I/O pts. available (<i>actual I/O points depend on I/O configuration selected</i>)	1664 (X+Y+CR+GX)	2688 (X+Y+CR+GX)	8192 (X+Y+GX+GY)
I/O module point density	2/4/8/16/32/64	2/4/8/16/32/64	2/4/8/16/32/64
I/O module slots per base	4/6/8	4/6/8	4/6/8
Local/local expansion			
Serial remote I/O (including local & exp. I/O)	320 in/320 out	320 in/320 out	1024 in/1024 out
Remote I/O Channels	1664 max.	1664 max.	4224 max.
I/O pts. per remote module channel	2	2	3
Ethernet Remote I/O (including local/exp. I/O) discrete I/O pts.	512	512	512; 2048 (port 3)
	Yes	Yes	Yes
	1664 max.	2688 max.	8192 max.
	(Including local and exp.I/O)	(Including local and exp.I/O)	(Including local and exp.I/O)
Analog I/O channels	map into V-memory	map into V-memory	map into V-memory
Remote I/O channels	Limited by power budget	Limited by power budget	Limited by power budget
I/O per remote channel	16,384 (limited to 1664)	16,384 (limited to 2688)	16,384 (16 fully expanded H4-EBC slaves using V-memory and bit-of-word instructions)
Performance			
Contact execution (boolean)	3.0µs	0.33µs	0.96µs
Typical scan (1K boolean)	8-10ms	2-3ms	4-5ms
Programming and Diagnostics			
RLL ladder style	Yes	Yes	Yes
RLL PLUS/flowchart style (Stages)	Yes/384	Yes/1024	Yes/1024
Run time editing	No	Yes	Yes
Supports Overrides	No	No	Yes
Variable/fixed scan	Variabile	Variabile	Fixed or variable
Instructions	113	170	210
Control relays	480	1024	2048
Timers	128	256	256
Counters	128	128	256
Immediate I/O	Yes	Yes	Yes
Subroutines	No	Yes	Yes
For/next loops	No	Yes	Yes
Timed interrupt	No	Yes	Yes
Integer math	Yes	Yes	Yes
Floating-point math	No	No	Yes
Trigonometric functions	No	No	Yes
Table instructions	No	Yes	Yes
PID	No	No	Yes
Drum sequencers	No	No	Yes
Bit of word	No	No	Yes
Real-time clock/calendar	No	Yes	Yes
Internal diagnostics	Yes	Yes	Yes
Password security	No	Yes	Multi-level
System and User error log	No	Yes	Yes
IBox instructions	No	No	Yes
CPU Ports Communications			
Built-in ports	2 ports	2 ports	4 ports
K-sequence (proprietary protocol)	Yes	Yes	Yes
DirectNET	Yes	Yes	Yes
Modbus master/slave	No	No	Yes
ASCII out (Print)	No	No	Yes
Maximum baud rate	19.2K	19.2K	38.4K

D4-450 Key Features

DL450 CPU

- D4-450 <--->
- D4-450DC-1 <--->
- D4-450DC-2 <--->



16 PID loops

The D4-450 CPU can process up to 16 PID loops directly in the CPU. You can select from various control modes including automatic control, manual control, and cascade control. There are a wide variety of alarms including Process Variable, Rate of Change, and Deviation. The various loop operation parameters are stored in V-memory, which allows easy access from operator interfaces. Setup is accomplished with our *DirectSOFT* Programming Software. An overview of the various loop specifications and features is on page 6-13.

Floating-point math

The D4-450 CPU supports IEEE format floating-point math calculations. This feature means the D4-450 includes full trigonometric functions and various forms of integer/floating point number conversions.

Power supplies

We offer a choice of three power supplies for the DL450 CPU. The power supplies are built into the CPU. Available power supplies are:

- 110/220 VAC version - D4-450
- 24 VDC version - D4-450DC-1
- 125 VDC version - D4-450DC-2

D4-450 CPU

The D4-450 provides all the capabilities of the D4-430 and D4-440 CPUs, plus several additional features such as *DirectSOFT5* IBox instructions.

Built-in CPU communications ports

The D4-450 offers four built-in ports for extra convenience. The 15-pin port offers our proprietary K-sequence protocol and is primarily used for programming connections to a D4-HPP-1 handheld programmer or to a PC running *DirectSOFT* software. It can also be used to connect to a *C-more* panel or other operator interfaces. The 6-pin phone jack also supports K-sequence; plus, it can be a *DirectNET* slave port or an ASCII output port. The bottom 25-pin port contains two logical ports with different pins for each port. It is primarily a networking port that supports *DirectNET* master/slave or Modbus master/slave protocols. The bottom port can be used as an ASCII output port for connections to devices that can accept ASCII input. It can also be used as a remote I/O Master. The Communications Ports table on the next page has a complete description of each port.

D4-450 offers four built-in communication ports

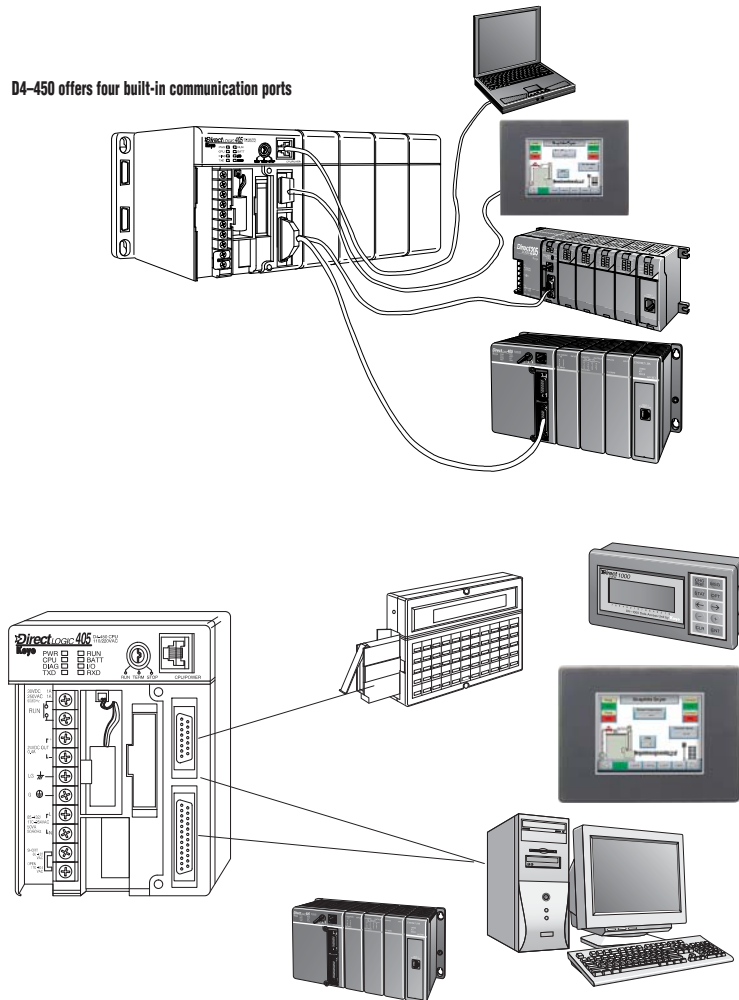

Note: if you are considering a D4-450 CPU to replace a CPU in an existing system, and the system uses specialty modules with an F4 prefix, then these modules may require an upgrade to operate with the D4-450. Contact our Technical Services group prior to placing your order for more information. (This note does not apply to analog modules.)

D4-450 Features

The diagrams on this page show the various hardware features found on the D4-450 CPU.

CPU Keyswitch		
RUN		Forces CPU to RUN mode. Locks Comm port - will not receive incoming data.
TERM		Allows peripherals (HPP, DCM, <i>DirectSOFT</i> , etc.) to select operating mode
STOP		Forces CPU out of RUN
CPU Status Indicators		
PWR	ON OFF	CPU power good CPU power failure
RUN	ON OFF	CPU is in RUN mode CPU is in STOP mode
CPU	ON OFF	CPU self-diagnostics error CPU self-diagnostics good
BATT	ON OFF	CPU battery is low CPU battery is good or disabled
DIAG	ON OFF	CPU diagnostics or local bus error CPU diagnostics or local bus good
I/O	ON OFF	I/O self-diagnostics error I/O self-diagnostics good
TXD	ON OFF	Data is being transmitted No data is being transmitted
RXD	ON OFF	Data is being transmitted No data is being transmitted
Communications Ports		
Phone Jack Port 2		Programming Port, RS232C, baud rate selectable up to 38.4Kb. Connects to <i>DirectSOFT</i> , DV-1000, <i>C-more</i> panels, network, etc. K-sequence protocol, <i>DirectNET</i> protocol (slave only), ASCII out
15-pin Port 0		Programming port, RS232C, 9600 baud, connects to HPP, <i>DirectSOFT</i> , DV-1000, <i>C-more</i> panels, etc. K-sequence protocol (fixed station address=1)
25-pin Port 1 and Port 3		General purpose port for RS232C and RS422. (RS485 Remote I/O Master available on Port 3 only.) Baud rate selectable via software up to 38.4K baud. Connects to <i>DirectSOFT</i> , <i>C-more</i> panels, network, etc. Two logical ports (separate pins on connector). Software selectable protocol includes:
	Protocol	Port 1 Port 3
	K-sequence	✓ ✓
	DirectNET Master/Slave	✓ ✓
	Modbus Master/Slave	✓ ✓
	Remote I/O	n/a ✓
	ASCII Out	✓ ✓

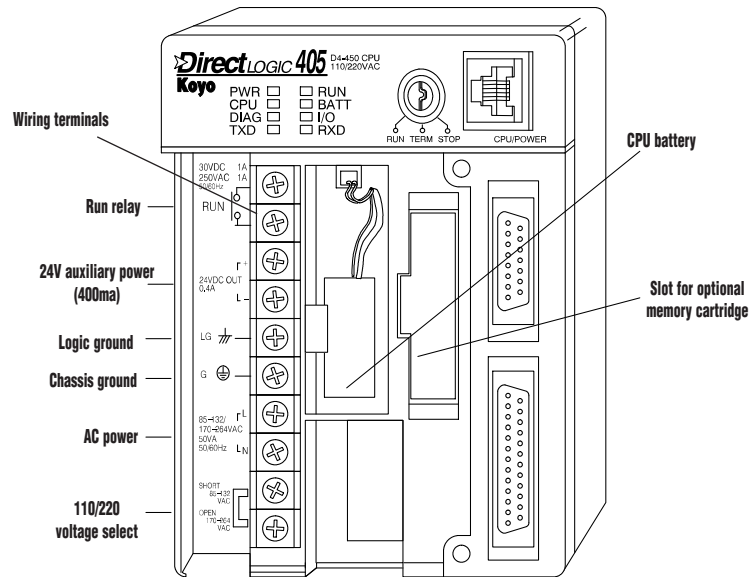

D4-450 communications ports pin-out

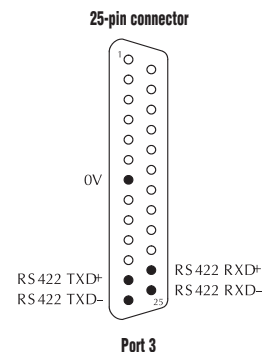
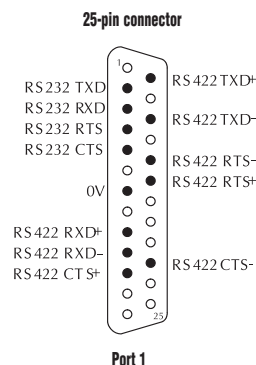
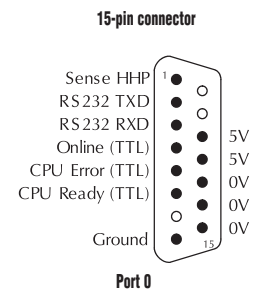
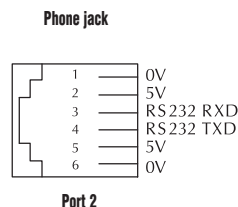

D4-450 Fixed or Variable Scan

D4-450 Scan control

The D4-450 CPU provides several scan control options, which are useful in some high-speed machine control applications.

Variable — The scan varies as necessary from scan to scan. The actual scan time depends on the instructions being executed.

Limited — This is similar to a variable scan in that the scan varies as necessary. However, if the actual scan time exceeds a specified target scan time, then a scan overrun condition is indicated.

Fixed — If the scan is finished before the time specified, idle time is added to ensure a fixed scan period. If the scan exceeds the time specified, the scan is extended to ensure all instructions are executed. A scan overrun condition is also reported.

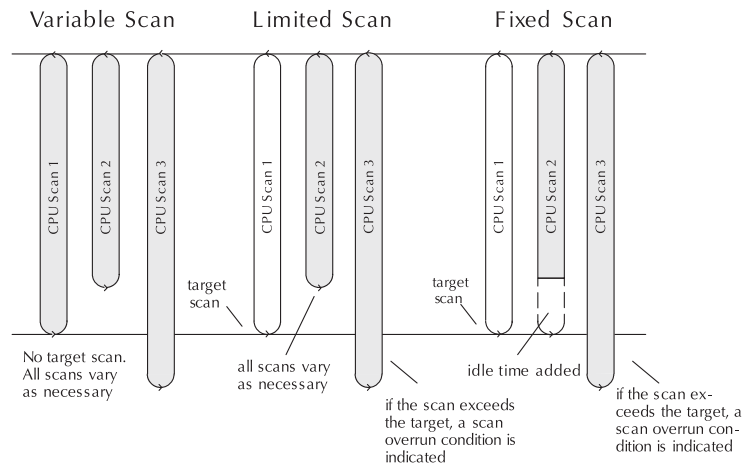

Memory

The D4-450 has 7.5K of flash memory on board. Upgrade to 15.5K by choosing an optional memory cartridge listed on page 6-14. The memory cartridge is recommended since it is removable in the event of problems.

Full array of instructions

Imagine if someone asked you to write a book, but then told you that you could only use 50 different words? That would be a tough job! The same is true for writing a PLC program. The right instruction can greatly simplify your control program.

The D4-450 supports over 200 powerful instructions. These include:

- Four types of drum sequencers, each with 16 steps and up to 16 outputs
- Leading and trailing edge triggered one-shots
- Bit of word manipulation (bit set, reset, etc.)
- Trigonometric functions
- Floating point conversions
- **Ibox** instructions that simplify tasks such as configuring analog modules or performing complex math equations

Rel. 2.1 of DirectSOFT, is required to program the D4-450.

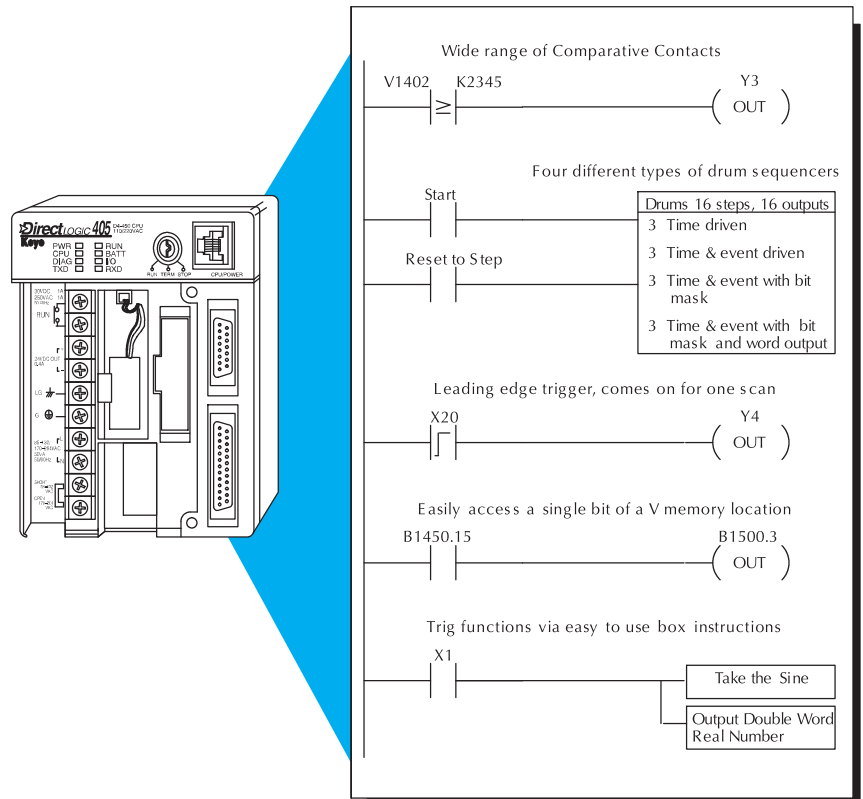

Note: if you are considering a D4-450 CPU to replace a CPU in an existing system, and the system uses specialty modules with an F4 prefix, then these modules may require an upgrade to operate with the D4-450. Contact our Technical Services group prior to placing your order for more information. (This note does not apply to Analog modules.)

D4-450 PID loops

PID Loop Specifications and Key Features	
Number of Loops	Selectable, 16 maximum
CPU V-memory Required	32 V-memory locations per loop selected (An additional 32 V-memory locations per loop required if using Ramp/Soak)
PID Algorithm	Position or velocity form of the PID equation. Optionally specify direct or reverse acting, square root of the error and error squared control.
Auto Tuning	Open loop step response method and closed loop limit cycle method.
Sample Rate	Specify the time interval between PV samples, 0.05 to 99.99 in units of seconds or minutes. If using all 16 loops, the smallest sample rate is limited to either 0.2 seconds or (PLC scan time x number of loops).
Loop Operation Modes	Loop can be in automatic control, manual (operator) control, or cascade control. PV alarm monitoring continues when loops are in manual mode.
Ramp/Soak	Up to 16 steps (8 ramp, 8 soak) per loop, with indication of Ramp/Soak step.
Square Root PV	Specify a square root of the PV for a flow control application.
Limit SP	Specify a maximum and minimum value for allowable setpoint changes.
Limit OUT	Specify a maximum and minimum value for the output range.
Gain	Specify proportional gain of 0.01 to 99.99.
Reset	Specify integral time of 0.1 to 99.98 in units of seconds or minutes.
Rate	Specify the derivative time, 0.00 to 99.99 seconds.
Rate Limiting	Specify a derivative gain limiting coefficient to filter the PV used in calculating the derivative term (0 to 20).
Bumpless Transfer I	Bias and setpoint are initialized automatically when the loop is switched from manual to automatic. This provides for a bumpless transfer, which reduces the chance of sharp changes in the output as a result of entering automatic mode.
Bumpless Transfer II	Bias is set equal to the Output when the module is switched from manual to automatic. This allows switching in and out of automatic mode without having to re-enter the setpoint.
Step Bias	Provides proportional bias adjustment for large setpoint changes. This may stabilize the loop faster and reduce the chance of the output going out of range. Step bias should be used in conjunction with the normal adjusted bias operation.
Anti-windup	If the position form of the PID equation is specified, the reset action is stopped when the PID output reaches 0 or 100%. Select adjusted bias or freeze bias operation.
Error Deadband	Specify an incremental value above and below the setpoint in which no change in output is made.
Error Squared	Squaring the error minimizes the effect a small error has on the Loop output, however, both Error Squared and Error Deadband control may be enabled.
Alarm Specifications	
Deadband	Specify 0.1% to 5% alarm deadband on all alarms except Rate of Change.
PV Alarm Points	Specify PV alarm settings for low-low, low, high, and high-high conditions. You can also specify a deadband to minimize the alarm cycles when the PV approaches alarm limits.
PV Deviation	Specify alarms to indicate two ranges of PV deviation from the setpoint value (yellow and red deviation).
Rate of Change	Specify a rate-of-change limit for the PV.
<p>Need Temperature Control? If you're only interested in controlling temperature, then there may be a better solution than the D4-450 CPU. Check out the F4-4LTC module. This module has the capabilities of our single loop controllers built into one economical module! Detailed specifications can be found later in this section. This module can directly control up to four loops and it even includes built-in relay outputs for heater or chiller control! If you use the built-in PID capability of the D4-450 CPU, you still have to purchase the analog input modules and the output modules (either discrete or analog) in order to complete the loop. This can result in a much higher overall cost when compared to the F4-4LTC.</p>	

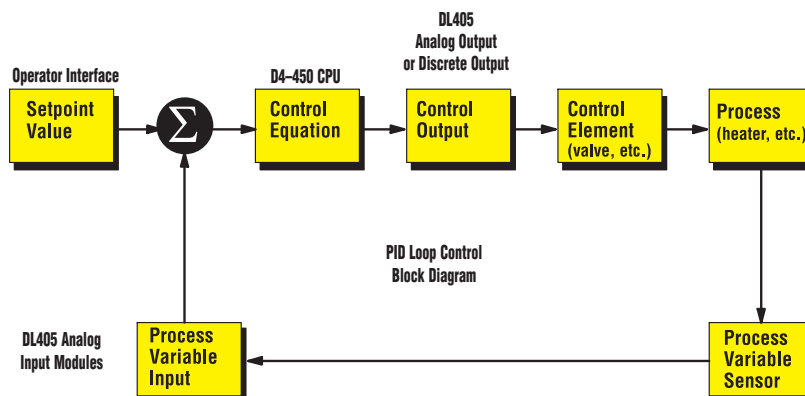

DL405 Programming Tools and Cables

Select a programming device

There are two tools for programming the DL405 CPUs: *DirectSOFT* PC-based programming software and the D4-HPP-1 handheld programmer.

DirectSOFT programming software

Our powerful Windows-based programming packages make it easy for you to program and monitor your DL405 PLC system. The version of the software that supports the DL405 CPUs is described in the table below. See the Software section in the desk reference for detailed information on *DirectSOFT*.

DirectSoft Part Number	Price	Description
PC-DSOFT5	<--->	Programs all PLC families DL05/06/105/205/305/405

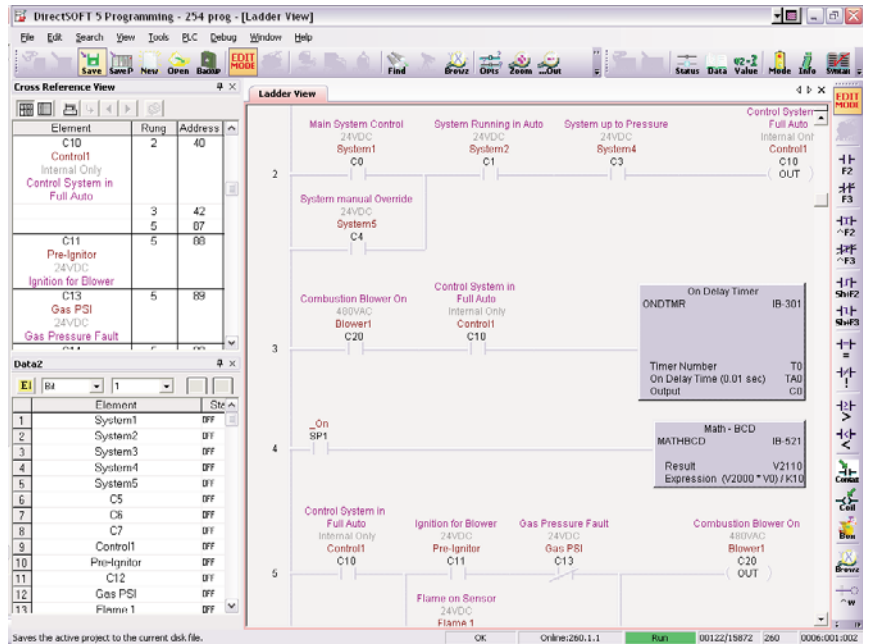

DL405 programming cables

Choose the proper cable to connect the DL405 CPU to your PC running *DirectSOFT*.

CPU	Price	Port	Cable	Price
D4-430/ D4-440	<--->	Top port (15 pin)	D4-DSCBL	<--->
	<--->	Lower port (25 pin)	D3-DSCBL-2	<--->
D4-450	<--->	Top port (15 pin)	D4-DSCBL	<--->
	<--->	Lower port (25pin)	D3-DSCBL-2	<--->
	<--->	Phone jack (RJ12)	D2-DSCBL	<--->

Pin labeling conforms to IBM DTE and DCE standards

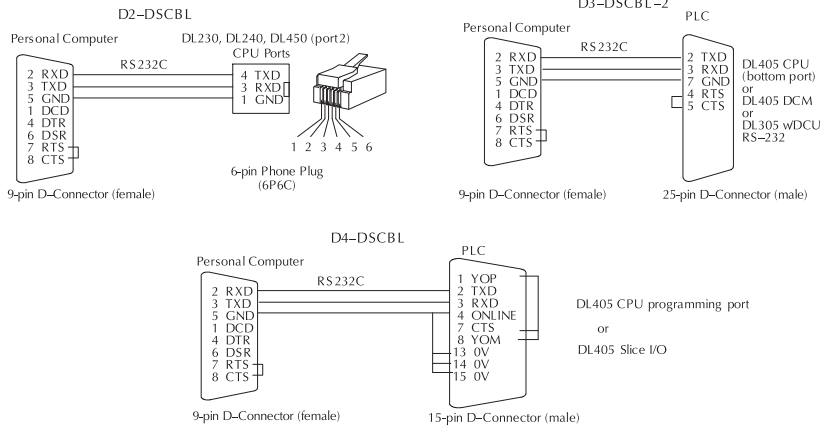

Handheld programmer

The D4-HPP-1 handheld programmer connects to the 15-pin port on any of the DL405 CPUs. A memory cartridge is located on the side of the handheld programmer. This slot allows you to copy memory cartridges (including UV PROMs) and transfer data/programs between the CPU and a memory cartridge.

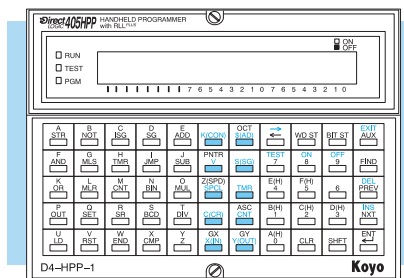

There are three optional connecting cables available for use with the D4-HPP-1 programmer:

- D4-HPCBL-1: 3m cable
- D4-HPCBL-2: 1.5m cable
- D4-CASCBL: cassette cable