



6-inch Micro-Graphic Panel

Hardware User Manual

EA1-MG6-USER-M

**C-more 6" Micro-Graphic Panel
EA1-S6ML - shown in Portrait Mode**

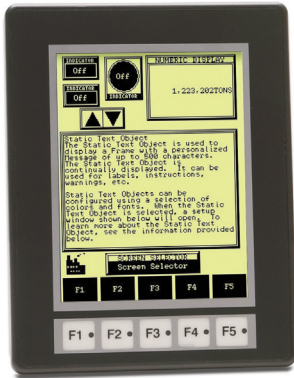

**C-more 6" Micro-Graphic Panel
EA1-S6MLW - shown in Landscape Mode**



**C-more 6" Micro-Graphic Panel Installed in a
21-button Portrait Keypad Bezel EA-MG6-BZ2P**



**C-more 6" Micro-Graphic Panel Installed in a
20-button Landscape Keypad Bezel EA-MG6-BZ2**





Graphic Panel - 6 Inch

HARDWARE USER MANUAL



Please include the Manual Number and the Manual Issue, both shown below, when communicating with Technical Support regarding this publication.

Manual Number: EA1-MG6-USER-M
Issue: 1st Edition Rev B.
Issue Date: 10/08

Publication History		
Issue	Date	Description of Changes
1st Edition	07/08	Original issue
Rev. A	10/08	Added CLICK PLC.
Rev. B	10/08	Added Mitsubishi Q / QnA

⚡ WARNING ⚡

Thank you for purchasing automation equipment from **Automationdirect.com**[®], doing business as, **AutomationDirect**. We want your new automation equipment to operate safely. Anyone who installs or uses this equipment should read this publication (and any other relevant publications) before installing or operating the equipment.

To minimize the risk of potential safety problems, you should follow all applicable local and national codes that regulate the installation and operation of your equipment. These codes vary from area to area and usually change with time. It is your responsibility to determine which codes should be followed, and to verify that the equipment, installation, and operation is in compliance with the latest revision of these codes.

At a minimum, you should follow all applicable sections of the National Fire Code, National Electrical Code, and the codes of the National Electrical Manufacturer's Association (NEMA). There may be local regulatory or government offices that can also help determine which codes and standards are necessary for safe installation and operation.

Equipment damage or serious injury to personnel can result from the failure to follow all applicable codes and standards. We do not guarantee the products described in this publication are suitable for your particular application, nor do we assume any responsibility for your product design, installation, or operation.

Our products are not fault-tolerant and are not designed, manufactured or intended for use or resale as on-line control equipment in hazardous environments requiring fail-safe performance, such as in the operation of nuclear facilities, aircraft navigation or communication systems, air traffic control, direct life support machines, or weapons systems, in which the failure of the product could lead directly to death, personal injury, or severe physical or environmental damage ("High Risk Activities"). **AutomationDirect** specifically disclaims any expressed or implied warranty of fitness for High Risk Activities.

For additional warranty and safety information, see the Terms and Conditions section of our catalog. If you have any questions concerning the installation or operation of this equipment, or if you need additional information, please call us at 770-844-4200.

This publication is based on information that was available at the time it was printed. At **AutomationDirect** we constantly strive to improve our products and services, so we reserve the right to make changes to the products and/or publications at any time without notice and without any obligation. This publication may also discuss features that may not be available in certain revisions of the product.

Trademarks

This publication may contain references to products produced and/or offered by other companies. The product and company names may be trademarked and are the sole property of their respective owners. **AutomationDirect** disclaims any proprietary interest in the marks and names of others.

**Copyright 2006-2008, Automationdirect.com[®] Incorporated
All Rights Reserved**

No part of this manual shall be copied, reproduced, or transmitted in any way without the prior, written consent of **Automationdirect.com[®] Incorporated**. **AutomationDirect** retains the exclusive rights to all information included in this document.

⚡ ADVERTENCIA ⚡

Gracias por comprar equipo de automatización de **Automationdirect.com**[®]. Deseamos que su nuevo equipo de automatización opere de manera segura. Cualquier persona que instale o use este equipo debe leer esta publicación (y cualquier otra publicación pertinente) antes de instalar u operar el equipo.

Para reducir al mínimo el riesgo debido a problemas de seguridad, debe seguir todos los códigos de seguridad locales o nacionales aplicables que regulan la instalación y operación de su equipo. Estos códigos varían de área en área y usualmente cambian con el tiempo. Es su responsabilidad determinar cuales códigos deben ser seguidos y verificar que el equipo, instalación y operación estén en cumplimiento con la revisión más reciente de estos códigos.

Como mínimo, debe seguir las secciones aplicables del Código Nacional de Incendio, Código Nacional Eléctrico, y los códigos de (NEMA) la Asociación Nacional de Fabricantes Eléctricos de USA. Puede haber oficinas de normas locales o del gobierno que pueden ayudar a determinar cuales códigos y normas son necesarios para una instalación y operación segura.

Si no se siguen todos los códigos y normas aplicables, puede resultar en daños al equipo o lesiones serias a personas. No garantizamos los productos descritos en esta publicación para ser adecuados para su aplicación en particular, ni asumimos ninguna responsabilidad por el diseño de su producto, la instalación u operación.

Nuestros productos no son tolerantes a fallas y no han sido diseñados, fabricados o intencionados para uso o reventa como equipo de control en línea en ambientes peligrosos que requieren una ejecución sin fallas, tales como operación en instalaciones nucleares, sistemas de navegación aérea, o de comunicación, control de tráfico aéreo, máquinas de soporte de vida o sistemas de armamentos en las cuales la falla del producto puede resultar directamente en muerte, heridas personales, o daños físicos o ambientales severos ("Actividades de Alto Riesgo").

Automationdirect.com específicamente rechaza cualquier garantía ya sea expresada o implicada para actividades de alto riesgo.

Para información adicional acerca de garantía e información de seguridad, vea la sección de Términos y Condiciones de nuestro catálogo. Si tiene alguna pregunta sobre instalación u operación de este equipo, o si necesita información adicional, por favor llámenos al número 770-844-4200 en Estados Unidos.

Esta publicación está basada en la información disponible al momento de impresión. En **Automationdirect.com** nos esforzamos constantemente para mejorar nuestros productos y servicios, así que nos reservamos el derecho de hacer cambios al producto y/o a las publicaciones en cualquier momento sin notificación y sin ninguna obligación. Esta publicación también puede discutir características que no estén disponibles en ciertas revisiones del producto.

Marcas Registradas

Esta publicación puede contener referencias a productos producidos y/u ofrecidos por otras compañías. Los nombres de las compañías y productos pueden tener marcas registradas y son propiedad única de sus respectivos dueños. **Automationdirect.com**, renuncia cualquier interés propietario en las marcas y nombres de otros.

PROPIEDAD LITERARIA 2006-2008, AUTOMATIONDIRECT.COM[®] INCORPORATED
Todos los derechos reservados

No se permite copiar, reproducir, o transmitir de ninguna forma ninguna parte de este manual sin previo consentimiento por escrito de **Automationdirect.com[®] Incorporated**. **Automationdirect.com** retiene los derechos exclusivos a toda la información incluida en este documento. Los usuarios de este equipo pueden copiar este documento solamente para instalar, configurar y mantener el equipo correspondiente. También las instituciones de enseñanza pueden usar este manual para propósitos educativos.

⚡ AVERTISSEMENT ⚡

Nous vous remercions d'avoir acheté l'équipement d'automatisation de **Automationdirect.com**[®], en faisant des affaires comme, **AutomationDirect**. Nous tenons à ce que votre nouvel équipement d'automatisation fonctionne en toute sécurité. Toute personne qui installe ou utilise cet équipement doit lire la présente publication (et toutes les autres publications pertinentes) avant de l'installer ou de l'utiliser.

Afin de réduire au minimum le risque d'éventuels problèmes de sécurité, vous devez respecter tous les codes locaux et nationaux applicables régissant l'installation et le fonctionnement de votre équipement. Ces codes diffèrent d'une région à l'autre et, habituellement, évoluent au fil du temps. Il vous incombe de déterminer les codes à respecter et de vous assurer que l'équipement, l'installation et le fonctionnement sont conformes aux exigences de la version la plus récente de ces codes.

Vous devez, à tout le moins, respecter toutes les sections applicables du Code national de prévention des incendies, du Code national de l'électricité et des codes de la National Electrical Manufacturer's Association (NEMA). Des organismes de réglementation ou des services gouvernementaux locaux peuvent également vous aider à déterminer les codes ainsi que les normes à respecter pour assurer une installation et un fonctionnement sûrs.

L'omission de respecter la totalité des codes et des normes applicables peut entraîner des dommages à l'équipement ou causer de graves blessures au personnel. Nous ne garantissons pas que les produits décrits dans cette publication conviennent à votre application particulière et nous n'assumons aucune responsabilité à l'égard de la conception, de l'installation ou du fonctionnement de votre produit.

Nos produits ne sont pas insensibles aux défaillances et ne sont ni conçus ni fabriqués pour l'utilisation ou la revente en tant qu'équipement de commande en ligne dans des environnements dangereux nécessitant une sécurité absolue, par exemple, l'exploitation d'installations nucléaires, les systèmes de navigation aérienne ou de communication, le contrôle de la circulation aérienne, les équipements de survie ou les systèmes d'armes, pour lesquels la défaillance du produit peut provoquer la mort, des blessures corporelles ou de graves dommages matériels ou environnementaux («activités à risque élevé»). La société **AutomationDirect** nie toute garantie expresse ou implicite d'aptitude à l'emploi en ce qui a trait aux activités à risque élevé.

Pour des renseignements additionnels touchant la garantie et la sécurité, veuillez consulter la section Modalités et conditions de notre documentation. Si vous avez des questions au sujet de l'installation ou du fonctionnement de cet équipement, ou encore si vous avez besoin de renseignements supplémentaires, n'hésitez pas à nous téléphoner au 770-844-4200.

Cette publication s'appuie sur l'information qui était disponible au moment de l'impression. À la société **AutomationDirect**, nous nous efforçons constamment d'améliorer nos produits et services. C'est pourquoi nous nous réservons le droit d'apporter des modifications aux produits ou aux publications en tout temps, sans préavis ni quelque obligation que ce soit. La présente publication peut aussi porter sur des caractéristiques susceptibles de ne pas être offertes dans certaines versions révisées du produit.

Marques de commerce

La présente publication peut contenir des références à des produits fabriqués ou offerts par d'autres entreprises. Les désignations des produits et des entreprises peuvent être des marques de commerce et appartiennent exclusivement à leurs propriétaires respectifs. **AutomationDirect** nie tout intérêt dans les autres marques et désignations.

Copyright 2006-2008, Automationdirect.com[®] Incorporated
Tous droits réservés

Nulle partie de ce manuel ne doit être copiée, reproduite ou transmise de quelque façon que ce soit sans le consentement préalable écrit de la société **Automationdirect.com[®] Incorporated**. **AutomationDirect** conserve les droits exclusifs à l'égard de tous les renseignements contenus dans le présent document.

TABLE OF CONTENTS



Chapter 1: Getting Started	1-1
Introduction	1-2
Conventions Used	1-3
Product Overview	1-4
Agency Approvals	1-4
Part Number Key	1-5
Product Label Example:	1-5
Serial Number and Date Code format:	1-5
Quick Start Steps	1-6
Step 1 – Unpack and Inspect	1-6
Step 2 – Install Optional Hardware Accessories	1-7
Step 3 – Become Familiar with Available Communication Ports	1-8
Step 4 – Install C-more 6" Micro-Graphic Panel	1-9
Enclosure Clearances	1-10
Step 5 – Connect C-more 6" Micro-Graphic Panel to Computer	1-11
Step 6 – Provide Power to the C-more 6" Micro-Graphic Panel	1-12
Step 7 – Accessing the C-more 6" Micro-Graphic Panel Setup Screens	1-13
Step 8 – Choose C-more 6" Micro-Graphic Panel to PLC Protocol & Cables	1-14
Step 9 – Install the Programming Software and Develop a Project	1-15
Step 10 – Connect C-more 6" Micro-Graphic Panel to PLC	1-16

Chapter 2: Specifications	2-1
Available Models	2-2
Model Specifications	2-3
Panel Dimensions	2-5
Communications Ports	2-6
Chemical Compatibility	2-7
Chapter 3: Accessories	3-1
Accessories	3-2
C-more Micro-Graphic Programming Software	3-3
USB to RS-232 Programming Cable Assembly	3-6
20-Button Landscape (Horizontal) Keypad Bezel	3-8
21-Button Portrait (Vertical) Keypad Bezel	3-11
D-SUB 15-pin 90-degree Communication Port Adapter	3-14
D-SUB 15-pin to Terminal Block Adapter	3-14
Clear Screen Overlay	3-15
Chapter 4: Installation and Wiring	4-1
Safety Guidelines	4-2
Introduction	4-3
Panel Cutout Dimensions (all models)	4-4
Wiring Guidelines	4-5
Chapter 5: System Setup Screens	5-1
Introduction	5-2
Accessing the System Setup Screens	5-3
System Setup Screens Flowchart	5-4
Setup Menu	5-5
Information Menu	5-6

Memory	5-6
Protocol	5-6
Extensions	5-6
Versions	5-6
Setting Menu	5-7
LCD Contrast	5-7
Backlight, Model EA1-S6ML	5-8
Backlight, Model EA1-S6MLW	5-9
Beep	5-10
Calibration	5-11
Clear User Memory	5-12
Reset to Factory Default	5-12
Hourglass	5-13
Rotation	5-14
Test Menu	5-15
Serial Port1 - Loop Back Test	5-15
Serial Port2 - Loop Back Test	5-16
PLC Enquiry Test	5-17
Buzzer Test	5-17
Touch Panel Test	5-18
Exit	5-18
Chapter 6: PLC Communications	6-1
Introduction	6-2
Available PLC Protocols	6-3
C-more 6" Micro-Graphic Communication Ports	6-4
DirectLOGIC PLCs Password Protection	6-6
PLC Compatibility and Connection Charts	6-6
AutomationDirect CLICK PLC:	6-6
Direct LOGIC PLCs RS-422A/RS-485A:	6-7
Allen-Bradley:	6-7
GE, Mitsubishi, Omron, Modicon and Siemens:	6-7
How to use the PLC Compatibility and Connection Charts	6-8
Example:	6-8
Cables from AutomationDirect	6-15
Cables from AutomationDirect – Wiring Diagrams	6-17

User Constructed Cables – Wiring Diagrams	6–26
RS-422A/RS-485A Multi-Drop Wiring Diagram Examples	6–32
Chapter 7: Maintenance	7–1
Project Backup	7–2
Check Operating Environment	7–2
Check Operating Voltage	7–2
Check Transmit and Receive Indicators	7–3
Check Physical Conditions	7–3
Run Tests under the System Setup Screens	7–4
Check Settings under the System Setup Screens	7–5
Cleaning the Display Screen	7–5
Check Project Functionality	7–6
Checks from the <i>C-more</i> Micro-Graphic Programming Software	7–6
Chapter 8: Troubleshooting	8–1
<i>C-more</i> Micro-Graphic Panel does not Power up	8–2
Display is Blank	8–2
Display is Dim	8–3
No User Program	8–3
Lost Firmware – Red ‘Update Mode’ Screen Displayed	8–4
Updating Firmware	8–4
No Communications between Panel and PC (Personal Computer)	8–5
No Communications between Panel and PLC	8–7
Panel & PLC Error Codes	8–8
<i>C-more</i> Micro-Graphic Panel Runtime Errors	8–9
Electrical Noise Problems	8–10
Chapter 9: Replacement Parts	9–1
Replacement Parts Overview	9–2
Replacement Parts	9–2

Customizing the Function Keys Insert Label	9-3
Appendix A: PLC Protocol Error Codes	A-1
Introduction	A-2
<i>C-more</i> Micro-Graphic Panel Error Code Table	A-3
Modbus Protocols Error Code P499 Explanation	A-4
AutomationDirect CLICK	A-4
AutomationDirect <i>Direct</i> LOGIC - Modbus (Koyo)	A-4
Modicon Modbus RTU	A-4
Entivity Modbus RTU	A-4
<i>Direct</i> LOGIC Error Code P499 Explanation	A-5
<i>Direct</i> LOGIC – K-Sequence PLC Error Code Table	A-5
<i>Direct</i> LOGIC – <i>Direct</i> NET PLC Error Codes	A-5
Allen-Bradley Error Code P499 Explanation	A-6
Allen-Bradley DF1 Protocol – PLC Error Code Tables	A-7
Allen-Bradley DH485 Protocol – PLC Error Code Tables	A-9
GE Error Code P499 Explanation	A-11
GE SNPX Protocol – PLC Error Code Tables	A-12
Mitsubishi FX Protocol – PLC Error Codes	A-21
Mitsubishi Q / QnA and Q Series – PLC Error Codes	A-21
Omron Error Code P499 Explanation	A-23
Omron Host Link Protocol – PLC Error Code Table	A-24
Omron FINS Protocol – PLC Error Code Table	A-25
Siemens Error Code P499 Explanation	A-28
Siemens PPI Protocol – PLC Error Code Table	A-29
Appendix B: <i>C-more</i> Micro-Graphic Panel Runtime Errors	B-1
Introduction	B-2
Runtime Errors	B-2

Index

GETTING STARTED



CHAPTER 1

In This Chapter...

Introduction	1-2
Conventions Used	1-3
Product Overview	1-4
Agency Approvals	1-4
Part Number Key	1-5
Product Label Example:	1-5
Serial Number and Date Code format:	1-5
Quick Start Steps	1-6
Step 1 – Unpack and Inspect	1-6
Step 2 – Install Optional Hardware Accessories	1-7
Step 3 – Become Familiar with Available Communication Ports	1-8
Step 4 – Install <i>C-more 6"</i> Micro-Graphic Panel	1-9
Enclosure Clearances	1-10
Step 5 – Connect <i>C-more 6"</i> Micro-Graphic Panel to Computer	1-11
Step 6 – Provide Power to the <i>C-more 6"</i> Micro-Graphic Panel	1-12
Step 7 – Accessing the <i>C-more 6"</i> Micro-Graphic Panel Setup Screens	1-13
Step 8 – Choose <i>C-more 6"</i> Micro-Graphic Panel to PLC Protocol & Cables	1-14
Step 9 – Install the Programming Software and Develop a Project	1-15
Step 10 – Connect <i>C-more 6"</i> Micro-Graphic Panel to PLC	1-16

Introduction

The Purpose of this Manual

Thank you for purchasing from our *C-more*[®] Micro-Graphic family of products. This manual describes *AutomationDirect.com's* *C-more* 6" Micro-Graphic panels, their specifications, included components and available accessories and provides you with important information for installation, connectivity and setup. The manual shows you how to install, wire and use the products. It also helps you understand how to interface the panels to other devices in a control system.

This user manual contains important information for personnel who will install the panels and accessories, and for the personnel who will be programming the panel. If you understand control systems making use of operating interfaces such as the *C-more* Micro-Graphic panels, our user manuals will provide all the information you need to get, and keep, your system up and running.

Supplemental Manuals

If you are familiar with industrial control type devices, you may be able to get up and running with just the aide of the Quick Start Guide that is included with each panel. You may also refer to the online help that is available in the *C-more* Micro-Graphic programming software.

Technical Support

We strive to make our manuals the best in the industry. We rely on your feedback to let us know if we are reaching our goal. If you cannot find the solution to your particular application, or, if for any reason you need technical assistance, please call us at:

770-844-4200

Our technical support group will work with you to answer your questions. They are available Monday through Friday from 9:00 A.M. to 6:00 P.M. Eastern Time. We also encourage you to visit our web site where you can find technical and non-technical information about our products and our company.

<http://www.automationdirect.com>

If you have a comment, question or suggestion about any of our products, services, or manuals, please fill out and return the 'Suggestions' card that was included with this manual.

Conventions Used



When you see the “notepad” icon in the left-hand margin, the paragraph to its immediate right will be a special note. The word **NOTE:** in boldface will mark the beginning of the text.



When you see the “exclamation mark” icon in the left-hand margin, the paragraph to its immediate right will be a warning. This information could prevent injury, loss of property, or even death (in extreme cases). The word **WARNING:** in boldface will mark the beginning of the text.

Key Topics for Each Chapter

The beginning of each chapter will list the key topics that can be found in that chapter.

Getting Started	
	
In This Chapter...	
General Information	1-2
Specifications	1-4

Product Overview

1



EA1-S6ML

shown in Landscape (Horizontal) mode

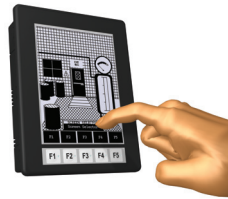

EA1-S6MLW

shown in Portrait (Vertical) mode

The *C-more 6"* Micro-Graphic panel has a 5.7-inch STN LCD monochrome 320 x 240 dot display. Model EA1-S6ML has five selectable LED-driven backlight colors including Green, Red, Amber, Yellow and Lime. Model EA1-S6MLW has five selectable LED-driven backlight colors including White, Pink1, Pink2, Pink3 and Red. Both models feature five user-defined function keys, each key with a user-defined red LED indicator. The panels can display up to 40 lines by 78 characters of static text and up to 40 lines by 40 characters of dynamic text with embedded variables and phrases mixed with graphics at landscape orientation. Portrait orientation can display 59 characters and 40 lines of static text and 40 lines by 40 characters of dynamic text. Each model is rated NEMA 4/4X, IP-65 (when mounted correctly, for indoor use only). The *C-more 6"* Micro-Graphic panels are powered from a 12-24 VDC power supply or can operate in low-power mode when powered from the serial communications port of select AutomationDirect PLCs.

Other features include:

- 1792 KB memory
- Built in RJ12 serial communications port (RS-232)
- Built in 15-pin serial communications port (RS-232/422/485)
- Adjustable contrast
- 2 optional keypad bezels, 20-button landscape and 21-button portrait mount
- Optional replaceable clear screen overlay
- Built in Alarm Control setup that activates beep, backlight flash, customized alarm banner, and red LED blinking
- Up to 999 screens, limited only by memory usage
- 0 to 50 °C (32 to 122 °F) operating temperature range
- UL, cUL & CE agency approvals (see below for details)
- 2-year warranty from date of purchase

Agency Approvals

UL/CUL/CE Certification Numbers				
Name	UL/CUL	UL508	CE	ISO-9000
C-more Micro-Graphic Panels & Accessories	E157382	E157382	EN61131-2	Yes



Part Number Key

Panel Part Number Key

The *C-more* 6" Micro-Graphic panel part numbers consist of the following:

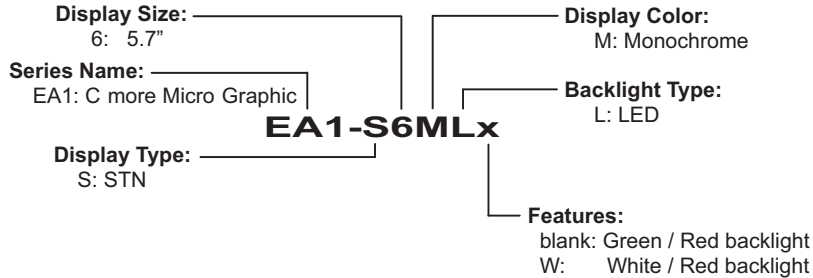

Bezel Part Number Key

The optional *C-more* 6" Micro-Graphic keypad bezel part numbers consist of the following:

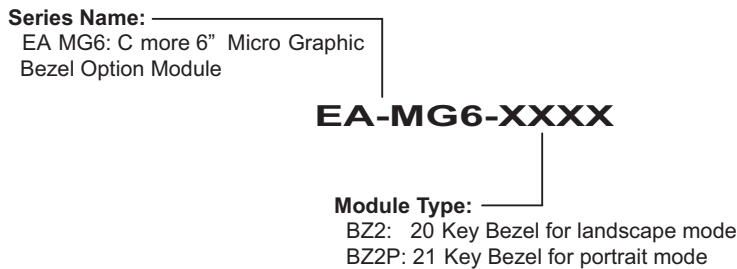

Product Label Example:

EA1-S6ML

EA1-S6MLW

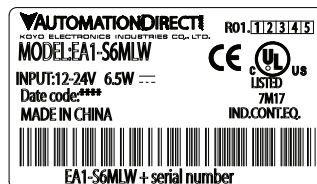

Serial Number and Date Code format:

Serial Number = [Part Number]+[YYMDDFFNNN]

Date Code = **YYMF**

- YY:** Year (07 99 --- e.g. 07 2007)
- M:** Month (1 9, X, Y, Z --- e.g. X Oct.)
- DD:** Day (1 31)
- F:** Manufacturing Site (0 9, A Z)
- NNN:** Sequence number for the date listed (000 999)

Quick Start Steps

1

Step 1 – Unpack and Inspect

a.) Unpack the *C-more* 6" Micro-Graphic panel from its shipping carton. Included in the carton are the following:

- *C-more* 6" Micro-Graphic panel (EA1-S6ML or EA1-S6MLW)
- DC power connector (EA-MG-DC-CON)
- cutout template
- mounting clips
- gasket
- function key label inserts
- Quick Start Guide

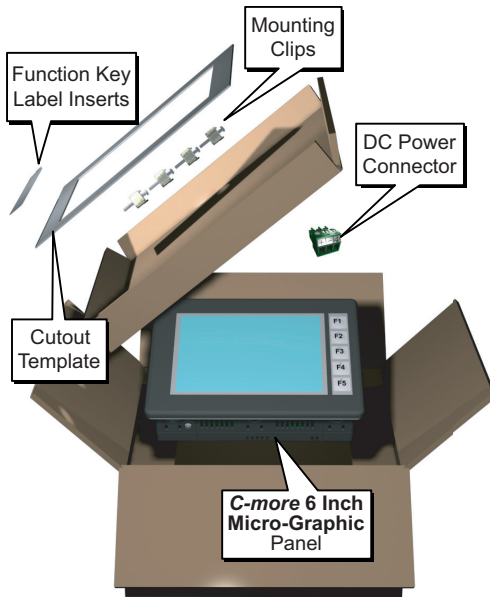

Shipping Carton Contents

b.) Unpack any accessories that have been ordered, such as:
Keypad Bezel, programming cable, PLC communications cable, etc.

c.) Inspect all equipment for completeness. If anything is missing or damaged, immediately call the *AutomationDirect*® returns department @ 1-800-633-0405.

Optional Accessories

**20-Button Horizontal Keypad Bezel
EA-MG6-BZ2**



**21-Button Vertical Keypad Bezel
EA-MG6-BZ2P**



Step 2 – Install Optional Hardware Accessories

Below is an example of a *C-more* 6" Micro-Graphic panel being assembled with an optional EA-MG6-BZ2 20-button Keypad Bezel.

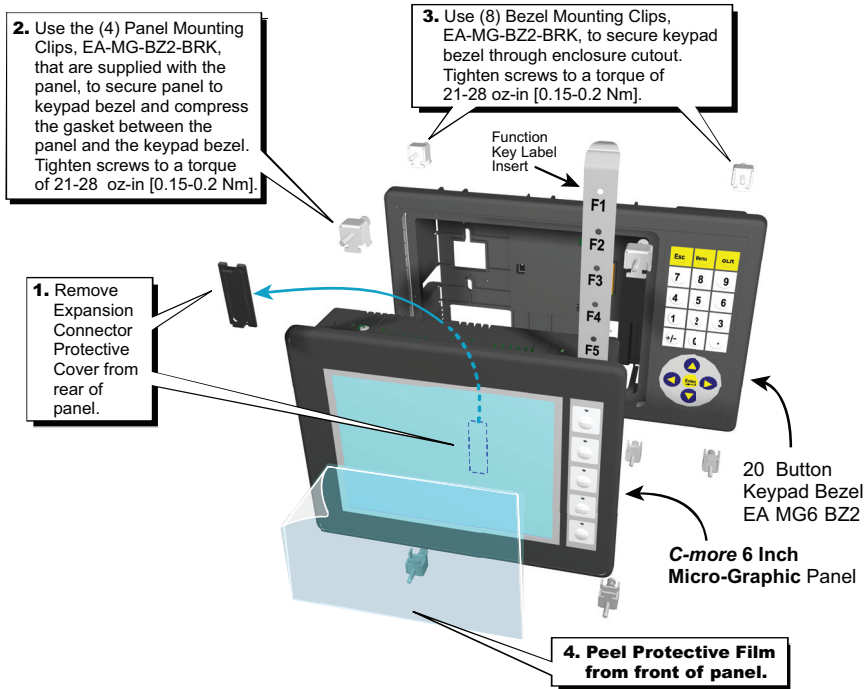

NOTE: Mounting clips for the panel and keypad bezels are included with the respective product.

Optional Accessory

Clear Screen Overlay
EA-6-COV2

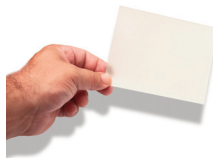

Step 3 – Become Familiar with Available Communication Ports

The *C-more* 6" Micro-Graphic panel includes a built-in RS-232 serial communications port designated as Port1. This port uses an RJ12 type telephone jack to make connections to either the EA-MG-PGM-CBL programming cable assembly or a communications cable, such as an EA-2CBL, to interface with a PLC or controller. The panel can receive power through this port from the serial communications port on AutomationDirect CLICK™ and select *Direct* LOGIC PLCs. The other serial communications port designated as Port2 is a 15-pin D-sub connector that supports RS-232, RS-485 and RS-422.



NOTE: When the 6" panel is powered through Port1 from a connected PLC or PC, the screen brightness is diminished because the panel is running in **Low-Power Mode**. For full brightness, connect an external 12-24 VDC power source to the panel's power connection. **Low-Power Mode** is intended for initial programming. For full brightness, connect an external 12-24 VDC power source when the panel is installed in its application.

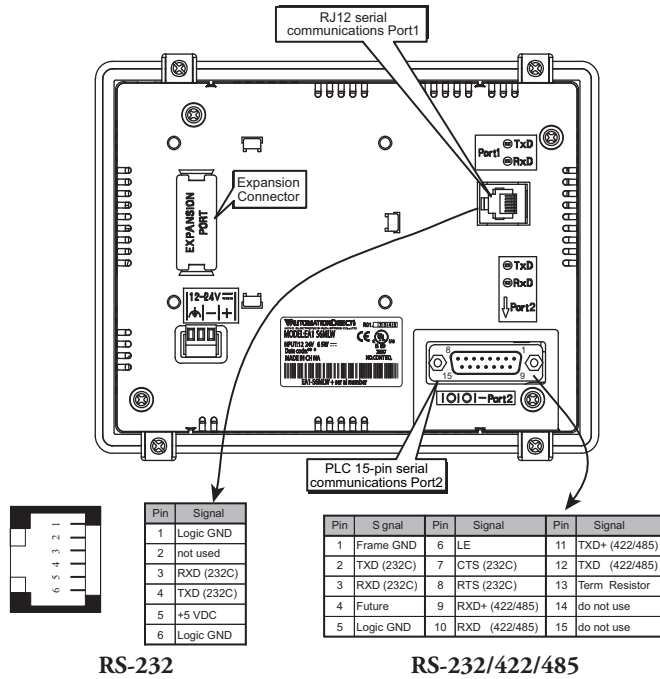

NOTE: See Chapter 2: Specifications and Chapter 6: PLC Communications for additional details on the available communication ports, protocols and cables.



NOTE: The panel has a built-in RJ12 serial communications port (Port1 - RS-232) and a built in 15-pin serial communications port (Port2 - RS-232/422/485). **Only one** of the ports can be used with a connected PLC. The programming software allows the user to select either Port1 or Port2 under the Panel Manager dialog box. When using Port2 to communicate with the connected PLC, Port1 can still be used with the EA-MG-PGM-CBL Software Programming Cable Assembly to transfer projects between the PC and panel.

Step 4 – Install *C-more* 6” Micro-Graphic Panel

The *C-more* 6” Micro-Graphic panel can be mounted through a cutout in an enclosure by using the template that is provided with the panel, or using the dimensions shown below. Cutout dimensions for the 20-button landscape and 21-button portrait keypad bezel options are also shown below. The keypad bezels also include a template that can be used. The enclosure mounting thickness range for the panels and the keypad bezels is 0.04”–0.2” [1–5 mm].

The screw torque range for the screws used on the panel mounting clips and the keypad bezel mounting clips is 21–28 oz-in [0.15–0.2 Nm].

See **Chapter 2: Specifications** for additional product dimensions.

Chapter 3: Accessories for accessory specifications and dimensions.

EA1-S6ML & EA1-S6MLW Panel Cutout

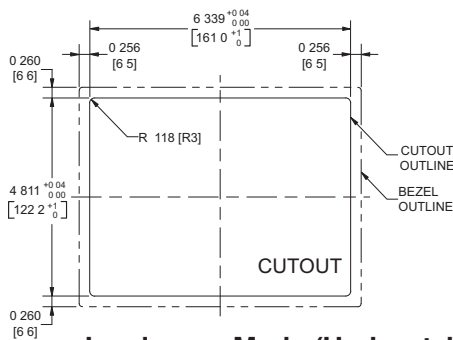

Landscape Mode (Horizontal)

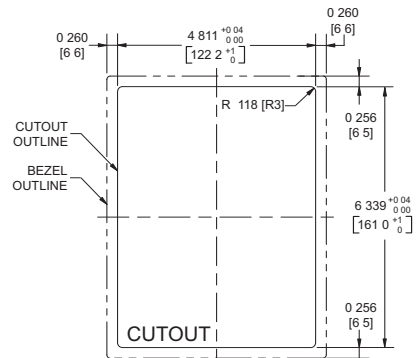

Portrait Mode (Vertical)

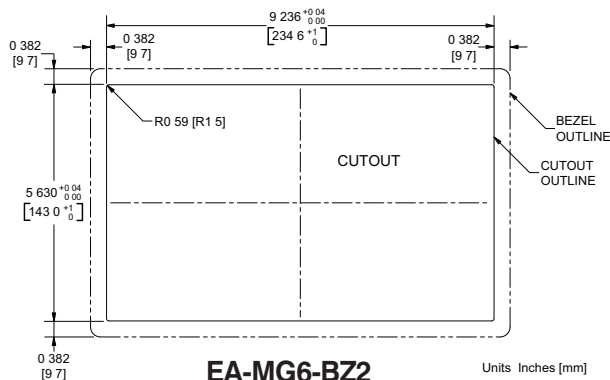

EA-MG6-BZ2
Landscape (Horizontal)
Keypad Bezel Cutout

Units: Inches [mm]

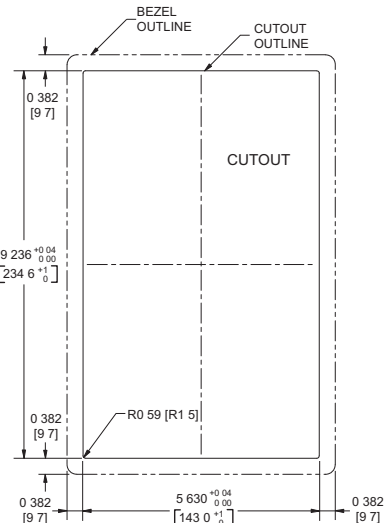

EA-MG6-BZ2P
Portrait (Vertical)
Keypad Bezel Cutout

Enclosure Clearances

A 1.2" [30mm] minimum clearance is required inside an enclosure for proper ventilation of the *C-more* Micro-Graphic panel.

**EA1-S6ML(W)
Rear View**

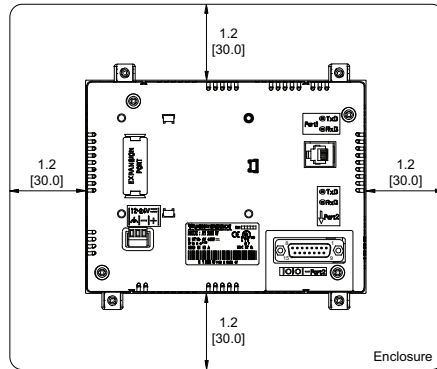

units: inches [mm]

**Panel with Keypad
Bezel**

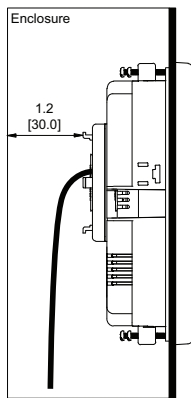

**EA1-S6ML(W) with
EA-MG6-BZ2(P)**

Panel only

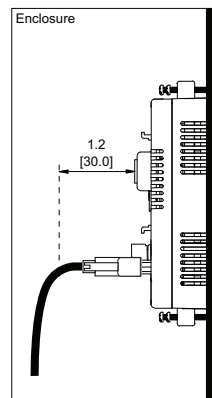

EA1-S6ML(W)



NOTE: Additional clearance inside the enclosure is required when connecting to the 15-pin serial communications port (Port2).

Step 5 – Install the Programming Software and Develop a Project

Following are the minimum system requirements for running *C-more* Micro-Graphic Programming Software, EA-MG-PGMSW, on a PC:

- Personal Computer with a 333 MHz or higher processor (CPU) clock speed recommended; (Windows® 2000 with Service Pack 4 or Windows® XP; 800 MHz or higher processor (CPU) clock speed recommended (Windows® Vista (32 bit)); Intel® Pentium/Celeron family, or AMD® K6/Athlon/Duron family, or compatible processor recommended)
- Keyboard and Mouse or compatible pointing device
- Super VGA color video adapter and monitor with at least 800 x 600 pixels resolution (1024 x 768 pixels recommended) 64K color minimum
- 150 MB free hard-disk space
- 128 MB free RAM (512 MB recommended); 512 MB free RAM (1GB recommended) for Vista
- CD-ROM or DVD drive for installing software from the CD, or internet access to download free programming software
- USB port to use with an EA-MG-PGM-CBL, USB to RS232 Programming Cable Assembly for project transfer from the programming software to the panel
- Operating System - Windows® XP Home / Professional Edition Service Pack 2, Windows® 2000 with Service Pack 4, or Windows® Vista (32 bit)

Insert the supplied CD-ROM into the PC's CD-ROM drive and follow the instructions. If you need assistance during the software installation, please refer to the supplied Software Installation Guide or call the *AutomationDirect* Technical Support team at 770-844-4200.

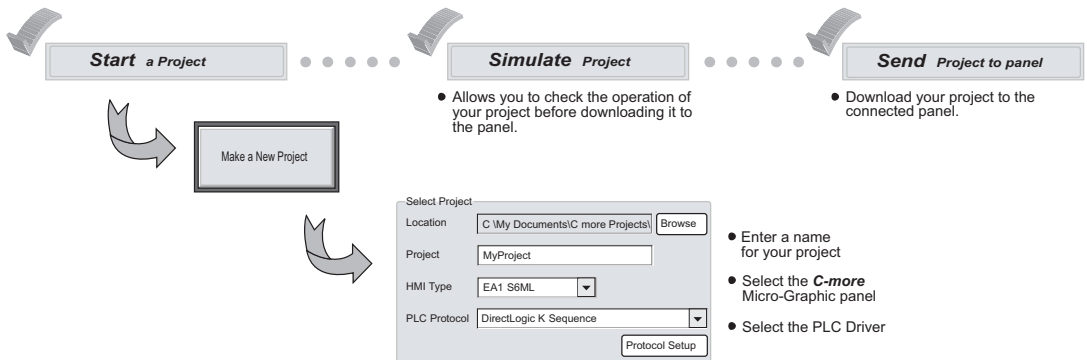

Step 6 – Connect *C-more* 6” Micro-Graphic Panel to Computer

NOTE: Install *C-more* Micro-Graphic Programming software before connecting the panel to the PC to ensure the panel drivers install correctly.

Use an EA-MG-PGM-CBL, USB to RS-232 Programming Cable Assembly, from an USB port type A on the project development PC, through the supplied converter, to the RJ12 RS-232 programming/PLC serial communications port on the *C-more* Micro-Graphic panel as shown below.

USB to RS-232 Programming Cable Assembly

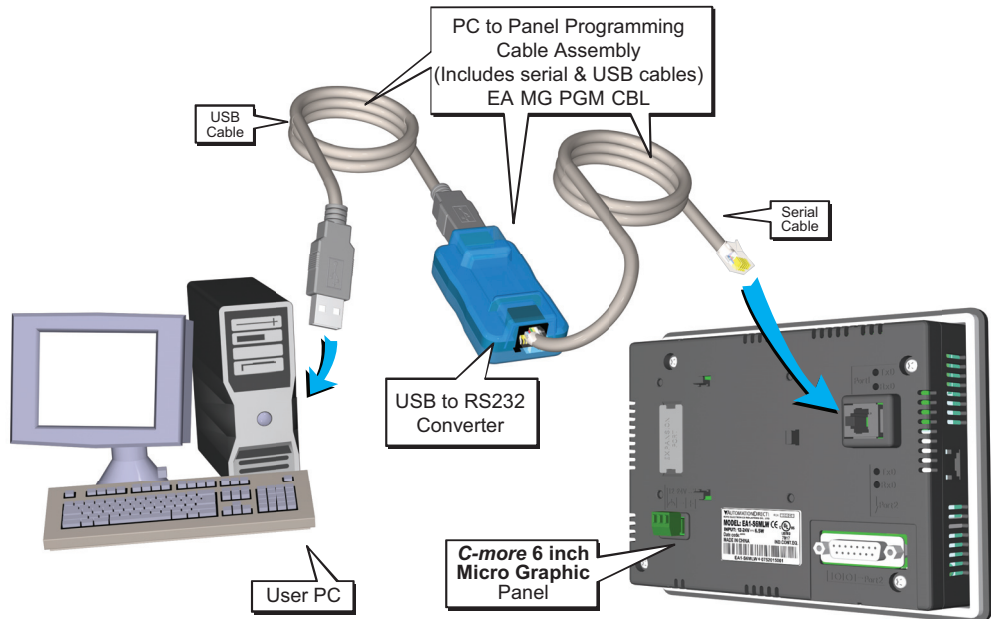

NOTE: When the panel is powered through Port1 from a connected PLC or PC, the screen brightness is diminished because the panel is running in **Low-Power Mode**. For full brightness, connect an external 12-24 VDC power source to the panel's power connection. **Low-Power Mode** is intended for initial programming. For full brightness, connect an external 12-24 VDC power source when the panel is installed in its application.

Step 7 – Providing Power to the *C-more 6*” Micro-Graphic Panel

Power can be supplied to the *C-more* Micro-Graphic panel in one of three different ways.

- 1.) During operation, the panel functions in High-Power Mode when powered by a minimum 1 Amp 12 - 24 VDC power source. Recommended power supplies are AutomationDirect part number PSP24-024S or PSP24-024C.
- 2.) The *C-more* Micro-Graphic panel is powered during programming from the PC through the USB to RS-232 Programming Cable Assembly, EA-MG-PGM-CBL. The panel will operate in Low-power mode when powered by the PC and result in a dim screen.
- 3.) Optionally, the *C-more* Micro-Graphic panel can function in Low-Power Mode powered from most *AutomationDirect* PLC's RJ12 serial communications port. Use a DV-1000CBL communications cable, or a DV-1000CBL communications cable with a FA-15HD 15-pin HD DSub/RJ12 Adapter connected to most AutomationDirect PLC's 15-pin HD communications port (DL06, D2-250-1 & D2-260) PLCs for Low-Power operation. See **Chapter 6: PLC Communications** for additional details. The panel will operate in low-power mode when powered by the PC.

*Panel Powered from AutomationDirect PLC via Communications Cable

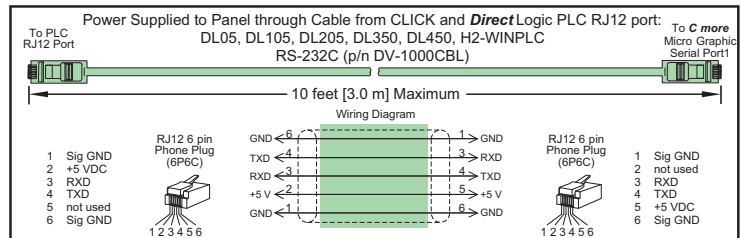

NOTE: When the 6” panel is powered through Port1 from a connected PLC or PC, the screen brightness is diminished because the panel is running in **Low-Power Mode**. For full brightness, connect an external 12-24 VDC power source to the panel's power connection. **Low-Power Mode** is intended for initial programming. For full brightness, connect an external 12-24 VDC power source when the panel is installed in its application.

Panel Powered from a DC Power Source - Wiring Diagram

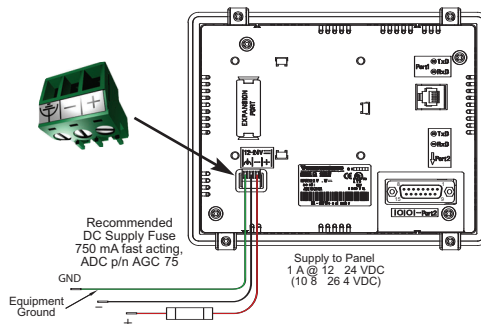

NOTE: Recommended DC power supply to power the *C-more* Micro Graphic Panel, *AutomationDirect* Part No. PSP24-024S or PSP24-024C.

Step 8 – Accessing the C-more 6” Micro-Graphic Panel Setup Screens

To access the Setup Menu of the panel's setup screens, press the the BAK [F1] and ENT [F5] function keys simultaneously for three (3) seconds.

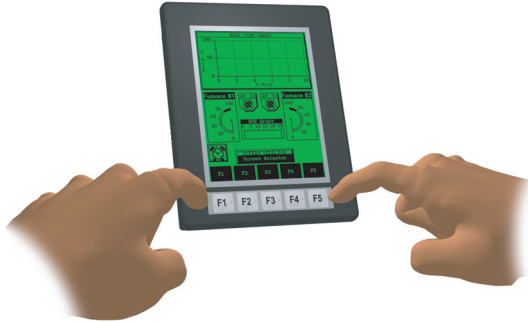

From the Setup Menu, information about the panel can be obtained, settings can be adjusted, and panel functions can be tested.



NOTE: See Chapter 5: System Setup Screens for details on using the setup screen settings and functions.

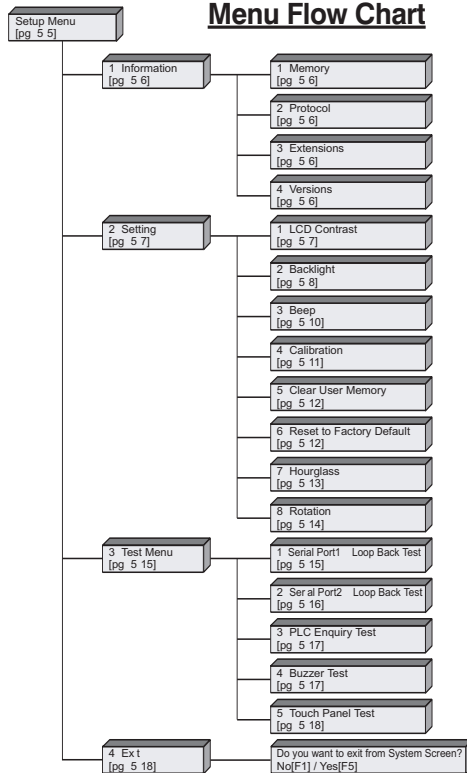
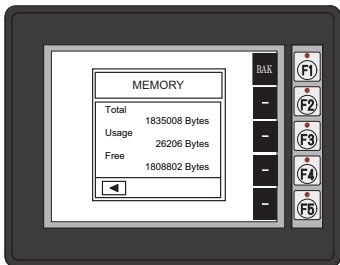
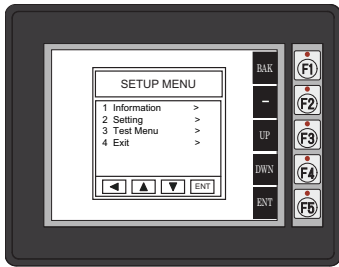

Step 9 – Choose *C-more 6*” Micro-Graphic Panel to PLC Protocol & CablesAvailable PLC Protocols

PLC Drivers	
<i>Serial - port1 or port2</i>	<i>Serial - port2 only</i>
AutomationDirect CLICK	Allen-Bradley DF1 Half Duplex
AutomationDirect K-sequence	Allen-Bradley DF1 Full Duplex
AutomationDirect DirectNET	Allen-Bradley PLC5 DF1
AutomationDirect Modbus	Allen-Bradley DH485
Modicon Modbus RTU	GE SNPX (90/30, 90/70, Micro 90, VersaMax Micro)
Entivity Modbus RTU	Mitsubishi FX
	Mitsubishi Q & QnA
	Omron Host Link (C200 Adapter, C500)
	Omron FINS Serial (CJ1, CS1)
	Siemens PPI (S7-200 CPU)

Available purchased cables

Cable Description	Cable Part No.
<i>Cables used with serial Port1</i>	
AutomationDirect CLICK, Direct LOGIC PLC RJ-12 port, DL05, DL06, DL105, DL205, D3-350, D4-450 & H2-WinPLC (RS-232C)	DV-1000CBL
Note: The PLC can provide 5 VDC through this cable. No external 12-24 VDC source is required, however, screen brightness is diminished and the alarm beep will not function.	
Direct LOGIC DL405 PLC 15-pin D-sub port, DL405 (RS-232C)	D4-1000CBL
Direct LOGIC (VGA Style) 15-pin port, DL06, D2-250 (250-1), D2-260 (RS-232C) Use with DV-1000CBL cable.	FA-15HD
Direct LOGIC PLC 15-pin D-sub port, DL405 (RS-232C).	FA-CABKIT
Direct LOGIC PLC RJ-11 port, D3-340 (RS-232C).	OP-3CBL-1

Cable Description	Cable Part No.
<i>Cables used with serial Port2</i>	
AutomationDirect CLICK, Direct LOGIC PLC RJ-12 port, DL05, DL06, DL105, DL205, D3-350, D4-450 & H2-WinPLC (RS-232C)	EA-2CBL
Direct LOGIC (VGA Style) 15-pin port, DL06, D2-250 (250-1), D2-260 (RS-232C).	EA-2CBL-1
Direct LOGIC PLC RJ-11 port, D3-340 (RS-232C).	EA-3CBL
Direct LOGIC DL405 PLC 15-pin D-sub port, DL405 (RS-232C).	EA-4CBL-1
Direct LOGIC PLC 25-pin D-sub port, DL405, D3-350, DL305 DCU and all DCM's (RS-232C).	EA-4CBL-2
Allen-Bradley MicroLogix 1000, 1100, 1200 & 1500 (RS-232C)	EA-MLOGIX-CBL
Allen-Bradley SLC 5-03/04/05, ControlLogix, CompactLogix, FlexLogix DF1 port (RS-232C)	EA-SLC-232-CBL
Allen-Bradley PLC-5 DF1 port (RS-232C)	EA-PLC5-232-CBL
Allen-Bradley MicroLogix, SLC 5-01/02/03, PLC5 DH485 port (RS-232C)	EA-DH485-CBL
GE 90/30, 90/70, Micro 90, Versamax Micro (Port2) 15-pin D-sub port (RS-422A)	EA-90-30-CBL
mitsubishi FX Series 25-pin port (RS-422A)	EA-MITSU-CBL
mitsubishi FX Series 8-pin mini-DIN (RS-422A)	EA-MITSU-CBL-1
OMRON Host Link (C200 Adapter, C500) (RS-232C)	EA-OMRON-CBL



NOTE: See Chapter 6: PLC Communications for a detailed chart of PLC compatibility & cable connections. Chapter 6 includes wiring diagrams for end user construction of certain cables.

Step 10 – Connect *C-more* 6” Micro-Graphic Panel to PLC

Connect the serial communications cable between the *C-more* Micro-Graphic panel and the PLC. The panel can be connected to the PLC via the panel’s built-in RJ12 serial communications port (RS-232) or 15-pin serial communications port with either RS-232, RS-422 or RS-485 communications.

1

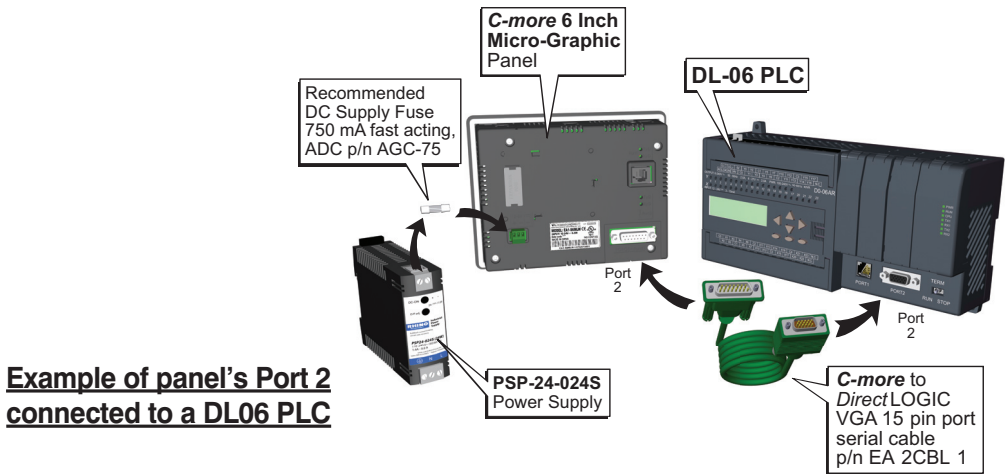
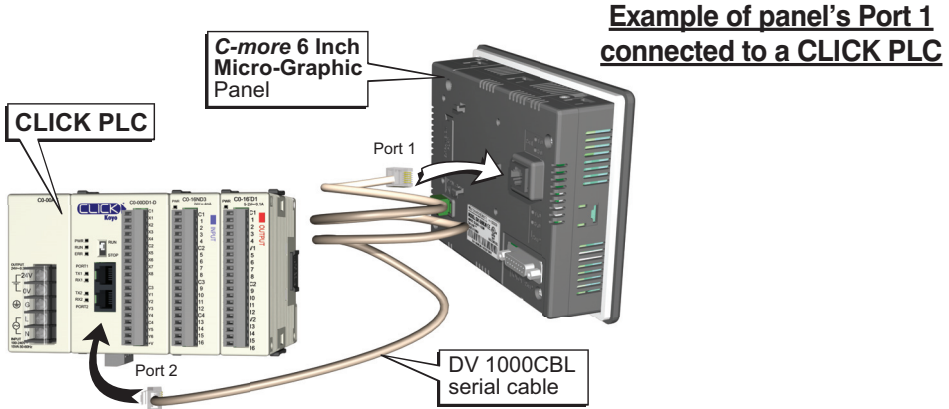

SPECIFICATIONS





In This Chapter...

Available Models	2-2
Model Specifications	2-3
Panel Dimensions	2-5
Communications Ports	2-6
Chemical Compatibility	2-7

Available Models

The *C-more* 6" Micro-Graphic panels expand the next generation of HMI panels brought to you by *AutomationDirect*. They have been designed to display and interchange graphical data from a PLC by viewing, using the function keys, or touching the screen.

The *C-more* 6" Micro-Graphic panel is available in two models to suit your application. Refer to the following table for part numbers, descriptions and general specifications. See **Chapter 3: Accessories** for details on the available accessories for the *C-more* 6" Micro-Graphic panels.

Micro-Graphic Panels	
Part Number	Description
EA1-S6ML	 <p>5.7-inch <i>C-more</i> Micro-Graphic Touch Panel with STN LCD monochrome, 320x240 dot display. The panel has red and green LED backlights. Supports 5 selectable backlight colors (Red, Green, Amber, Lime, and Yellow). Includes 5 user-defined function keys with LED indicators. 2 built in serial Ports (RS-232 RJ12 port and 15 pin D-sub RS-232/422/485). NEMA 4/4X, IP-65 (when mounted correctly; for indoor use only).</p>
EA1-S6MLW	 <p>5.7-inch <i>C-more</i> Micro-Graphic Touch Panel with STN LCD monochrome, 320x240 dot display. The panel has white and red LED backlights. Supports 5 selectable backlight colors (White, Pink1, Pink2, Pink3, and Red). Includes 5 user-defined function keys with LED indicators. 2 built in serial Ports (RS-232 RJ12 port and 15 pin D-sub RS-232/422/485). NEMA 4/4X, IP-65 (when mounted correctly; for indoor use only).</p>

C-more 6" Micro-Graphic Panel



C-more 6" Micro-Graphic Panels Installed in Landscape and Portrait Keypad Bezels



Model Specifications

Specifications	
Description:	320 x 240 dots LCD display(Landscape Mode), five user defined keypad function buttons, and five user defined LEDs
Display:	
• Type	5 7" STN monochrome LCD, graphical characters
• Resolution	320 (W) x 240 (H) dots (Landscape Mode) 240 (W) x 320 (H) dots (Portrait Mode)
• Color	2 colors (normal / inverse)
• Viewing Area Size	4.614" (W) x 3.480" (H) [117.2 mm x 88.4 mm]
• Active Area Size	4.535" (W) x 3.400" (H) [115.2 mm x 86.4 mm]
• Contrast	Adjusted from the panel's built-in configuration setup menu
• Viewing Angle	3, 9 o'clock axis → 45 degrees 6 o'clock axis → 40 degrees 12 o'clock axis → 20 degrees
Backlight:	
• Type	LED
• Color	Model EA1-S6ML : 5 user defined colors: Red, Green, Amber, Lime, and Yellow
	Model EA1-S6MLW: 5 user defined colors: White, Pink1, Pink2, Pink3 and Red
• User Replaceable	No
Touch Screen:	
• Type	Analog touch panel
• Operation	82 gram force [0.8 N] maximum
• Life	Minimum of 1,000,000 cycles
Features:	
• User Memory	1792 kBytes
• Number of Screens	Up to 999 – limited by project memory usage
• Beep (Internal)	Yes
• Keypad Function Buttons	Five user defined function key push buttons with the ability to label. Minimum of 500,000 cycles
• Keypad Function Button LEDs	Each function key button includes a red LED that can be user programmed.
• Serial Communications	Built-in RJ12 serial communications port (RS-232) and 15-pin D-sub serial communications port (RS-232, RS-485/422).
• Expansion Connection	Yes – used with optional Keypad Bezels, EA-MG6-BZ2 & EA-MG6-BZ2P.

Specification table continued at the top of the next page.

Model Specifications (cont'd)

2

Specifications (cont'd)		
Screen Objects:		
• Functional Devices	Push Button, Switch, Indicator Button, Indicator Light, Graphic Indicator Light, Numeric Display, Numeric Entry, Inc/Dec Value, Bar Graph, Bitmap Button, Static Bitmap, Dynamic Bitmap, Recipe Button, Static Text, Lookup Text, Dynamic Text, Screen Change Push Button, Screen Selector, Adjust Contrast, Function, Key Configuration Object, Real Time Graph, Line Graph, Analog Meter.	
• Static Shapes	Lines, Rectangles, Circles and Frames	
• Displayable Fonts	Fixed fonts: 6x6, 6x8, 8x16, 16x16, 32x16, 32x32, and Windows fonts	
Electrical:		
	Low Power Mode	High Power Mode
• Input Voltage Range	5.0 VDC (4.75 – 5.25 VDC)	12/24 VDC (10.2 – 26.4 VDC)
• Input Power	Supplied through the panel's RJ12 serial communications port connection when used with most AutomationDirect PLCs having a RJ12 communication port or from a PC during programming.	Supplied from an external 12-24 VDC power source
• Power Consumption	1.05 W @ 5 VDC (210 mA)	6.5 W @ 10.2 VDC (630 mA), 12 VDC (540 mA), 24 VDC (250 mA)
• Recommended Fuse	No fuse required when directly connected to a PLC or PC with recommended cable.	Type AGC fast acting glass fuse, 750 mA, 250 VAC, ADC p/n AGC-75
• Max. Inrush Current	1 A for 500 µs	10 A for 500 µs
• Acceptable External Power Drop	Maximum 1 ms	
Environmental:		
• Operating Temperature	0 to 50 °C (32 to 122 °F)	
• Storage Temperature	-20 to +60 °C (-4 to +140 °F)	
• Humidity	5–95% RH, non-condensing	
• Environmental Air	No corrosive gases permitted	
• Vibration	IEC60068-2-6 (Test Fc), 5-9 Hz: 3.5 mm amplitude, 9-150 Hz: 1.0G, sweeping, at a rate of 1 octave/min. (±10%), 10 sweep cycles per axis on each of 3 mutually perpendicular axes	
• Shock	IEC60068-2-27 (Test Ea), 15 G peak, 11 ms duration, three shocks in each direction per axis, on 3 mutually perpendicular axes (total of 18 shocks)	
• Noise Immunity	NEMA ICS3-304 RFI, (145 MHz, 440 MHz 10 W @ 10 cm) Impulse 1000 V @ 1 µs pulse	
• Enclosure	NEMA 4/4X, IP-65 (When mounted correctly, for indoor use only.)	
• Agency Approvals	CE (EN61131-2), UL508, CUL Canadian C22.2 No. 142-M95, UL File E157382	
Physical:		
• Dimensions	6.850" (W) x 5.331" (H) x 2.13" (D) [174.0 mm x 135.4 mm x 54.1 mm] (Landscape Mode) 5.331" (W) x 6.850" (H) x 2.13" (D) [135.4 mm x 174.0 mm x 54.1 mm] (Portrait Mode)	
• Enclosure Mounting Thickness Range	0.04" – 0.2" [1 – 5 mm]	
• Mounting Clip Screw Torque Range	21 – 28 oz-in [0.15 – 0.2 Nm]	
• Depth from bezel rear	1.894" [47.1 mm]	
• Weight	30.69 oz. (870 g)	

Panel Dimensions

Panel Dimensions

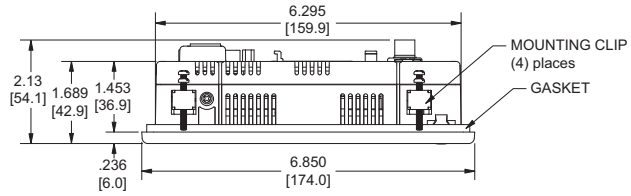

Units: Inches [mm]

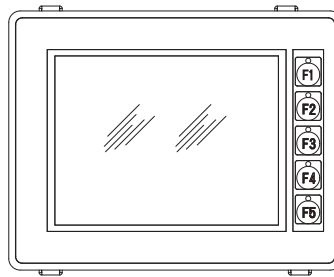
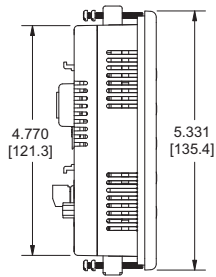

Enclosure Thickness

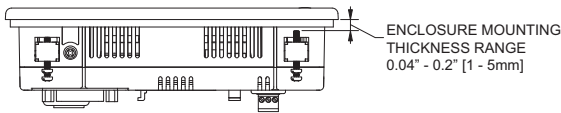

Mounting Clip Screw Torque

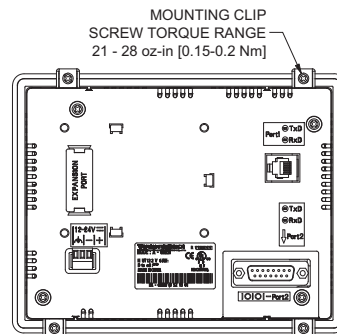

Communications Ports

2

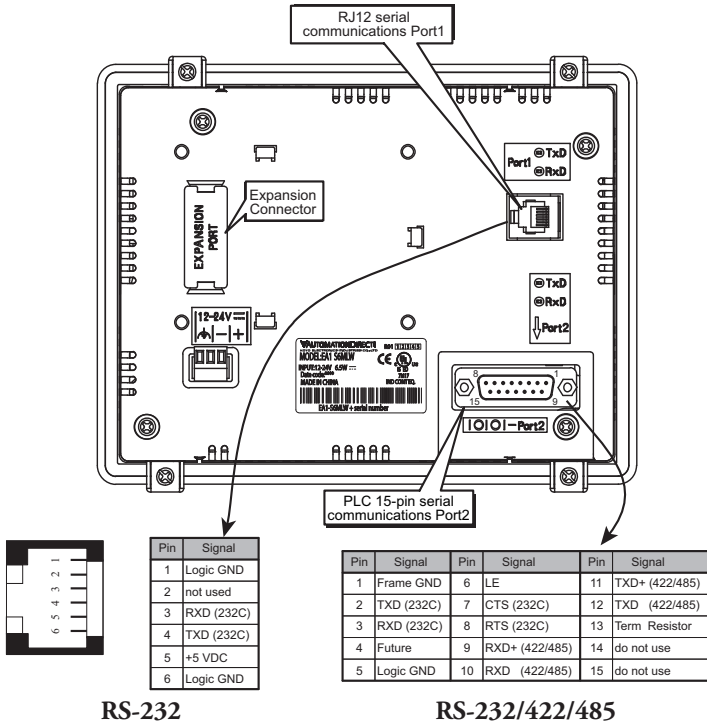

NOTE: The panel has one built-in RJ12 serial communications port (Port1 - RS-232) and one 15-pin serial communications port (Port2 - RS-232/422/485). **Only one** of the ports can be used with a connected PLC. The programming software allows the user to select either Comm. Port1 or Comm. Port2 under the Panel Manager dialog box. When using Port2 to communicate with the connected PLC, Port1 can still be used with the EA-MG-PGM-CBL Software Programming Cable Assembly to transfer projects between the PC and panel.

Chemical Compatibility

The *C-more* Micro-Graphic panels are built of three different materials that may be exposed to elements outside of the enclosure. The panel's screen has a polyester (PET) surface. The bezel uses ABS plastic materials and the panel's gasket is a silicone rubber material. The following tables are provided to make you aware of the general compatibility between chemicals that may be present in your work environment and the various materials used in the manufacture of the panel. Use the table to determine those chemicals that are safe to use around your *C-more* Micro-Graphic panel and those that may harm it. The tables are made up of specifications provided by the manufacturer of the listed material. The tables rate these chemicals as either Excellent, Good, Not Recommended, or Not Usable. Because the ratings are for ideal conditions at room temperature, consider all factors when evaluating your application. Areas left blank have not been tested by the manufacturer and therefore information of compatibility is not available.

Chemicals	Screen Sheet – PC [Density %, Temperature °C]	Bezel – ABS [Density %, Temperature °C]	Gasket – Silicone [Density %, Temperature °C]	Bezel Key Sheet – PET [Density %, Temperature °C]
Acetaldehyde		Not Recommended		
Acetic Acid		[10, 20 °C] Excellent		
		[10, 20 °C] Excellent		
		[50, 20 °C] Not Usable		
		[50-70, 20 °C] Not Usable		
		[100, 20 °C] Not Usable		
Acetic anhydride		Not Recommended		
Acetone	Not Usable	Not Usable		Excellent
Acetophenone		Not Usable		
Acetylene		Excellent		
Acrylonitrile		Not Recommended		
Alcohol - Butyl Ether			Excellent	
Alcohol - Ethanol			Excellent	
Alcohol - Isopropyl			Excellent	
Alums NH ₃ , Cr, K		Excellent		
Aluminum acetate		Excellent		
Aluminum bromide		Good		
Aluminum chloride		Good		
Aluminum nitrate		Excellent		
Aluminum sulfate		Excellent		
Ammonia [anhydrous]		Good		
Ammonia gas [cold]		Good		

Table continued at top of next page.

Chemical Compatibility (cont'd)

Chemicals	Screen Sheet – PC [Density %, Temperature °C]	Bezel – ABS [Density %, Temperature °C]	Gasket – Silicone [Density %, Temperature °C]	Bezel Key Sheet – PET [Density %, Temperature °C]
Ammonia liquid		Good		
Ammonia water		[12%] Not Usable		
		[28%] Not Usable		
Ammonium carbonate		Excellent		
Ammonium chloride		Excellent		
Ammonium hydroxide [ammonia water]		Excellent		
Ammonium nitrate		Excellent		
Ammonium persulfate		Excellent		
Ammonium phosphate		Excellent		
Ammonium sulfate		Excellent		
Amyl acetate		Not Usable		
Amyl alcohol		Good		
Aniline dyes		Not Recommended		
Animal oil [lard]		Good		
Aqua regia		Not Usable		
Arsenic acid		Not Recommended		
Asphalt		Excellent		
Barium chloride		Excellent		
Barium hydroxide		Excellent		
Barium sulfate		Excellent		
Barium sulfide		Excellent		
Beer		Excellent		
Beet sugar liquors		Excellent		
Benzaldehyde		Not Recommended		
Benzene [Benzol]		Not Recommended		
Benzene				Excellent
Benzine		Not Usable	Not Usable	
Benzyl alcohol		Not Recommended		
Benzyl benzoate		Not Usable		
Benzyl chloride		Not Usable		
Borax		Excellent		
Boric acid		Good		
Bromine		Not Usable		

Table continued at top of next page.

Chemical Compatibility (cont'd)

Chemicals	Screen Sheet – PC [Density %, Temperature °C]	Bezel – ABS [Density %, Temperature °C]	Gasket – Silicone [Density %, Temperature °C]	Bezel Key Sheet – PET [Density %, Temperature °C]
Butane		Excellent		
Butter		Good		
Butyl acetate		Not Usable		
Butyl acrylate		Not Usable		
Butyl alcohol		[Butanol] Good		
Butyl Cellosolve	Not Usable			
Calcium acetate		Excellent		
Calcium bisulfite		Good		
Calcium chloride		Excellent		
Calcium hydroxide		Excellent		
Calcium hypochlorite		[20, 20 °C] Excellent		
Calcium nitrate		Excellent		
Calcium sulfide		Excellent		
Cane sugar liquors		Excellent		
Carbon dioxide		Excellent		
Carbon disulfide		Not Usable		
Carbonic acid		Good		
Carbon tetrachloride		Not Usable		Excellent
Castor oil		Not Recommended		
China wood [tung] oil		Excellent		
Chlorine gas [dry]		Not Usable		
Chlorine gas [wet]		Not Usable		
Chlorine liquid		Not Usable		
Chlorinated solvents		Not Usable		
Chloroacetic acid		Not Usable		
Chloroacetone		Not Usable		
Chloroform		Not Usable		Excellent
Chlorophenol				Not Usable
Chlorosulfonic acid		Not Usable		
Chlorotoluene		Not Usable		
Chromic acid		[2, 70 °C] Not Usable		
		[5, 70 °C] Not Usable		
		[10, 70 °C] Not Usable		
		[25, 70 °C] Not Usable		

Table continued at top of next page.

Chemical Compatibility (cont'd)

Chemicals	Screen Sheet – PC [Density %, Temperature °C]	Bezel – ABS [Density %, Temperature °C]	Gasket – Silicone [Density %, Temperature °C]	Bezel Key Sheet – PET [Density %, Temperature °C]
Citric acid		Good		
Cocoonut oil		Good		
Concentrated HCl	Excellent			
Copper chloride		Excellent		
Copper cyanide		Excellent		
Copper sulfate		Excellent		
Corn oil		Good		
Cottonseed oil		Good		
Creosol		Not Usable		
Cyclohexane		Good		
Cyclohexanol		Good		
Cyclohexanone	Not Usable	Not Usable		
Developing solutions [Hypos]		Excellent		
Dibutyl phthalate [DBP]		Not Usable		
Dichlorobenzene		Not Usable		
Diethylene glycol		Good		
Diethyl ether		Not Usable		
Disopropyl ketone		Not Usable		
Dimethyl aniline		Not Usable		
Dimethyl formamide		Not Usable		
Dioxane		Not Usable		
Dipentene		Not Usable		
Epichlorohydrine		Not Usable		
Ethyl acetate	Not Usable	Not Usable		Excellent
Ethyl acetoacetate		Not Usable		
Ethyl acrylate		Not Usable		
Ethyl alcohol		Not Recommended		Excellent
Ethyl benzene		Not Usable		
Ethyl chloride		Not Usable		
Ethylene chlorohydrin		Not Usable		
Ethylene diamine		Not Usable		
Ethylene dichloride		Not Usable		
Ethylene glycol		Excellent		

Table continued at top of next page.

Chemical Compatibility (cont'd)

Chemicals	Screen Sheet – PC [Density %, Temperature °C]	Bezel – ABS [Density %, Temperature °C]	Gasket – Silicone [Density %, Temperature °C]	Bezel Key Sheet – PET [Density %, Temperature °C]
Ethylene oxide		Not Usable		
Fatty acid		Good		
Ferric chloride		Excellent		
Ferric nitrate		Excellent		
Ferric sulfate		Excellent		
Fluorboric acid		Not Recommended		
Fluorobenzene		Not Usable		
Fluosilicic acid		Not Recommended		
Formaldehyde		[40, 20 °C] Good		
		[25, 20 °C] Excellent		
		[50, 20 °C] Good		
		[90, 20 °C] Not Recommended		
Freon				[45° C] Excellent
Freon 11		Not Recommended		
Freon 12		Good		
Freon 113		Not Usable		
Freon 114		Not Recommended		
Fuel oil		Good		
Gasoline	Excellent	Not Recommended	Not Usable	
Gelatin		Excellent		
Glauber's salt		Excellent		
Glue		Excellent		
Glycerin		Excellent		
Grease		Excellent		
Hexane		Not Recommended		
Hexyl alcohol		Good		
Hydrobromic acid		[20, 20 °C] Not Usable		
		[20-70, 20 °C] Not Usable		
		[37, 20 °C] Not Usable		
Hydrochloric acid		[10, 20 °C] Excellent	Good	[15%] Excellent
		[20, 20 °C] Good		
		[20-80, 20 °C] Not Recommended		
		[38, 20 °C] Not Recommended		[30%] Good

Table continued at top of next page.

Chemical Compatibility (cont'd)

Chemicals	Screen Sheet – PC [Density %, Temperature °C]	Bezel – ABS [Density %, Temperature °C]	Gasket – Silicone [Density %, Temperature °C]	Bezel Key Sheet – PET [Density %, Temperature °C]
Hydrocyanic acid		Excellent		
Hydrofluoric acid		[10, 20 °C] Excellent		
		[20, 20 °C] Excellent		
		[40,RT] Good		
Hydrofluoric acid anhydrous		Not Usable		
Hydrogen		Excellent		
Hydrogen peroxide		[5, 20 °C] Not Recommended		
		[5-50, 20 °C] Not Recommended		
		[30, 20 °C] Not Usable		
Hydrogen sulfide		Excellent		
Hedorquinone		Not Recommended		
Hypochlorous acid		Not Recommended		
Isobutyl alcohol		Good		
Isopropyl acetate		Not Usable		
Isopropyl alcohol	Excellent	Good		
JP fuels (1-6)		Good		
Kerosene		Good		
Lacquer		Not Usable		
Lactic acid		Excellent		
Lard		Excellent		
Lead acetate		Excellent		
Lead nitrate		Good		
Lead sulfamate		Good		
Linoleic acid		Excellent		
Linseed oil		Excellent		
Liquified petroleum gas [LPG]		Excellent		
Lubricating oil		Excellent		
Lye solution		Excellent		
Magnesium chloride		Excellent		
Magnesium hydroxide		Excellent		
Magnesium sulfate		Excellent		
Maleic acid		Excellent		

Table continued at top of next page.

Chemical Compatibility (cont'd)

Chemicals	Screen Sheet – PC [Density %, Temperature °C]	Bezel – ABS [Density %, Temperature °C]	Gasket – Silicone [Density %, Temperature °C]	Bezel Key Sheet – PET [Density %, Temperature °C]
Mercuric chloride		Excellent		
MEK	Not Usable			Good
Mercury		Excellent		
Metacresol				Not Usable
Methyl acetate		Not Usable		
Methyl alcohol		Not Recommended		Excellent
Methyl Benzoate				Not Usable
Methyl chloride	Not Usable	Not Usable		
Methyl ethyl ketone [MEK]		Not Usable		
Methyl isobutyl ketone [MIBK]		Not Usable		
Methyl methacrylate		Not Usable		
Methyl dichloride		Not Usable		
Methyl Salicylate				Not Usable
Milk		Excellent		
Mineral oil		Excellent	Excellent	
Monochlorobenzene		Not Usable		Not Usable
Naptha		Good		
Napthalene		Excellent		
Napthenic acid		Good		
Natural gas		Excellent		
Natural oil			Excellent	
Nickel acetate		Excellent		
Nickel chloride		Excellent		
Nickel sulfate		Excellent		
Nitric acid		[10, 20 °C] Good		[30%] Good
		[10-70, 20 °C] Not Usable		
		[30, 20 °C] Not Usable		
		[30-70, 20 °C] Not Usable		[30%] Not Usable
		[61.3, 20 °C] Not Usable		
[Vapor, RT] Not Usable				
Nitrobenzene		Not Usable		Not Usable
Nitroethane		Not Usable		
Nitromethane		Not Usable		

Table continued at top of next page.

Chemical Compatibility (cont'd)

Chemicals	Screen Sheet – PC [Density %, Temperature °C]	Bezel – ABS [Density %, Temperature °C]	Gasket – Silicone [Density %, Temperature °C]	Bezel Key Sheet – PET [Density %, Temperature °C]
Nitropropane		Not Usable		
Nitrogen		Excellent		
Octyl alcohol		Good		
Oleic acid		Excellent		
Olive oil		Excellent		
Oxalic acid		Excellent		
Oxygen		Excellent		
Ozone		Not Recommended		
Palmitic acid		Excellent		
Perchloroethylene		Not Usable		
Petroleum		Excellent		
Phenol		Not Usable		Not Usable
Phosphoric acid		[50, 20 °C] Good		
		[50-70, 20 °C] Not Usable		
		[75, 20 °C] Not Usable		
Pickling solution		[Sulfuric acid 20% + nitric acid 4%] Good		
		[Sulfuric acid 40% + nitric acid 15%] Not Recommended		
Pine oil		Good		
Potassium chloride		Excellent		
Potassium cyanide		Excellent		
Potassium dichromate		[10, 20 °C] Excellent		
Potassium hydroxide		Excellent		[10%] Not Usable
Potassium nitrate		Excellent		
Potassium permangante		[5, 20 °C] Excellent		
Potassium sulfate		Excellent		
Propane		Excellent		
Propyl acetate		Not Usable		
Propyl alcohol		Good		
Salt water		Excellent		
Silicone oils		Good		
Silver nitrate		Excellent		

Table continued at top of next page.

Chemical Compatibility (cont'd)

Chemicals	Screen Sheet – PC [Density %, Temperature °C]	Bezel – ABS [Density %, Temperature °C]	Gasket – Silicone [Density %, Temperature °C]	Bezel Key Sheet – PET [Density %, Temperature °C]
Skydrol 500		Not Usable		
Skydrol 7000		Not Usable		
Soap solutions		Excellent		
Soda ash		Excellent		
Sodium bicarbonate		Excellent		
Sodium bisulfate		Good		
Sodium borate		Excellent		
Sodium carbonate				[10%] Excellent
Sodium chloride		Excellent		
Sodium cyanide		Excellent		
Sodium hydroxide		[10, 20 °C] Excellent	Good	[1%] Excellent
		[30, 20 °C] Excellent		[10%] Not Usable
		[30-70, 20 °C] Not Usable		
Sodium hydrochlorite		[5, 20 °C] Excellent		
		[5-70, 20 °C] Not Usable		
Sodium metaphosphate		Excellent		
Sodium nitrate		Excellent		
Sodium perborate		Excellent		
Sodium peroxide		Not Usable		
Sodium phosphate		Excellent		
Sodium thiosulfate		Excellent		
Sodium sulfate [Glauber's salt]		Good		
Sodium sulfite		Excellent		
Soybean oil		Excellent		
Stannic chloride		Good		
Steam		[below 150 degrees] Not Usable		
Steam		[above 150 degrees] Not Usable		
Stearic acid		Excellent		
Styrene		Not Recommended		
Sucrose solutions		Excellent		
Sulfur		Excellent		
Sulfur dioxide		Good		

Table continued at top of next page.

Chemical Compatibility (cont'd)

2

Chemicals	Screen Sheet – PC [Density %, Temperature °C]	Bezel – ABS [Density %, Temperature °C]	Gasket – Silicone [Density %, Temperature °C]	Bezel Key – PET [Density %, Temperature °C]
Sulfuric acid		[10, 20 °C] Excellent	Not Usable	[20%] Excellent
		[10-70, 20 °C] Not Usable		
		[30, 20 °C] Excellent		
		[30-70, 20 °C] Not Recommended		
		[98, 20 °C] Not Usable		
		[Vapor, 20 °C] Not Usable		[80%] Not Usable
Sulphurous acid		[10, 20 °C] Good		
Tannic acid		Good		
Tar		Not Recommended		
Tartaric acid		Excellent		
Terpineol		Not Recommended		
Tetrachloroethane		Not Usable		Excellent
Tetraethyl lead		Good		
Tetralin				Not Usable
Tetrahydrofuran		Not Usable	Not Usable	
Thionyl chloride		Not Usable		
Toluene	Not Usable	Not Usable	Not Usable	Excellent
Trichloroethylene [Trichlene]		Not Usable		
Triethanol amine		Good		
Turpentine oil		Good		
Vegetable oil		Good		
Vinegar		Excellent		
Water	Excellent	Excellent		
Whiskey		Excellent		
Xylene	Not Usable	Not Usable		Excellent
Zeolites		Excellent		
Zinc acetate		Excellent		
Zinc chloride		Excellent		
Zinc sulfate		Excellent		

ACCESSORIES







In This Chapter...

Accessories	3-2
<i>C-more</i> Micro-Graphic Programming Software	3-3
USB to RS-232 Programming Cable Assembly	3-6
20-Button Landscape (Horizontal) Keypad Bezel	3-8
21-Button Portrait (Vertical) Keypad Bezel	3-11
D-SUB 15-pin 90-degree Communication Port Adapter	3-14
D-SUB 15-pin to Terminal Block Adapter	3-14
Clear Screen Overlay	3-15

Accessories

3

Micro-Graphic Programming Software & Programming Cable		
Part Number		Description
EA-MG-PGMSW		C-more Micro-Graphic panel Windows-based configuration software. Requires Windows 2000 with Service Pack 4, XP Home or Professional with Service Pack 2 or Windows Vista. Requires USB port connection from PC to touch panel. Includes CD-ROM. Programming cable (EA-MG-PGM-CBL) sold separately. Downloadable version available from the Web site at no charge. Software Help Files included in download.
EA-MG-PGM-CBL		6-ft. cable assembly to connect personal computer to any C-more Micro-Graphic panel for setup and programming. (Note: This cable assembly uses the PC's USB port and converts the signals to serial transmissions. The USB port supplies 5 VDC to the Micro-Graphic panel for low-power mode configuration operations). Assembly includes standard USB A-type connector to B-type connector cable, custom converter, and an RS232C cable with RJ12 modular connector on each end.

Micro-Graphic Panel Accessories		
Part Number		Description
EA-MG6-BZ2		For Landscape (Horizontal) Mounted Panels. 20-button keypad bezel with numeric keypad for C-more 6" Micro-Graphic panels, 4 arrow adjust keys, and ESCAPE, MENU, CLEAR and ENTER buttons. Helps to reduce screen wear in heavy-duty applications where operators can use the keypad to enter numeric data. Designed for easy drop-in of the Micro-Graphic panels.
EA-MG6-BZ2P		For Portrait (Vertical) Mounted Panels. 21-button keypad bezel with numeric keypad for C-more 6" Micro-Graphic panels, 4 arrow adjust keys, and ESCAPE, MENU, CLEAR and (2) ENTER buttons. Helps to reduce screen wear in heavy-duty applications where operators can use the keypad to enter numeric data. Designed for easy drop-in of the Micro-Graphic panels.
EA-6-COV2		Optional clear screen overlay used to protect C-more Micro-Graphic displays from minor scratches and wear. Package contains 3 clear screen overlays.

C-more Micro-Graphic Programming Software

C-more[®] Micro-Graphic Programming Software is a spin-off of its powerful sibling *C-more* Touch Panel. It offers very high end features designed to reduce your configuration time. Simply drag and drop the objects from the object bar (right side of screen) onto the the screen construction area. Then configure your PLC tags and click on the objects you wish to use. Use the built-in simulator to review your work on your PC before ever downloading your project!



3



NOTE: Software and Firmware Version 2.0 or later is required with models EA1-S6ML and EA1-S6MLW. Available for free download at www.automationdirect.com.

Thumbnail project preview pane

Helps keep track of multi-screen projects.

Built-in user object/screen libraries

Save time by re-using your custom objects and screens.

Scrolling object selection window

Lets you find the object you want fast. Just drag and drop it on the screen.

Scrolling help window

Gives you helpful information on each object

Built-in project simulator

- Runs your project on your PC
- Test all of your screens before downloading
- Time savings pays for the panel

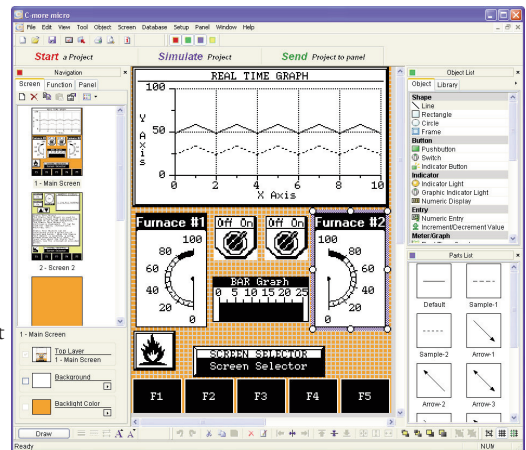

PC Requirements:

Following are the minimum system requirements for running *C-more* 6" Micro-Graphic Programming Software, EA-MG-PGMSW, on a PC:

- USB port for project transfer from software to touch panel
- Personal Computer with a 333 MHz or higher processor (CPU) clock speed recommended; (Windows® 2000 with Service Pack 4 or Windows® XP, 800 MHz or higher processor (CPU) clock speed recommended (Windows® Vista (32 bit)); Intel® Pentium/Celeron family, or AMD® K6/Athlon/Duron family, or compatible processor recommended
- Keyboard and Mouse or compatible pointing device
- Super VGA color video adapter and monitor with at least 800 x 600 pixels resolution (1024 x 768 pixels recommended) 64K color minimum
- 150 MB free hard-disk space
- 128 MB free RAM (512 MB recommended); 512 MB free RAM (1GB recommended) for Vista
- CD-ROM or DVD drive for installing software from the CD or internet access to download
- Operating System - Windows® XP Home / Professional Edition with Service Pack 2, Windows® 2000 with Service Pack 4 or Windows® Vista









Micro-Graphic Programming Software (cont'd)

3

C-more Micro-Graphic Panel Objects			
Object	Graphic	Object	Graphic
<p>The Line object, just like with drawing tools, allows the user to insert a straight line drawing into a project. When a Line is inserted into a project, a window opens to allow the user to setup all available parameters for the Line object. Some of the uses for Line Objects include but are not limited to adding callouts, pointers, or indicators.</p>		<p>The Numeric Display consists of a frame that displays a real-time numeric value according to the value of data received from an assigned Tag Name. The Numeric Display supports numeric Signed Decimal, Unsigned Decimal, BCD, and Floating Point data types with up to 11 digits, including decimal point. User Defined Alpha Numeric Prefix and Suffix values are also supported.</p>	
<p>The Rectangle object, just like with drawing tools, allows the user to insert a drawing of a Rectangle as well as other geometric shapes into a project. When this object is inserted into a project, a window opens to allow the user to setup all available parameters for the Rectangle object.</p>		<p>The Numeric Entry object is used to enter a value from your Panel to a PLC Register. This object, when selected, opens a Numeric Keypad that allows the user to enter a new value that will be written to the assigned Tag Name. The Numeric Entry supports numeric Signed Decimal, Unsigned Decimal, BCD, and Floating Point data types with up to 11 digits, including decimal points. User Defined Alpha Numeric Prefix and Suffix values are also supported.</p>	
<p>The Circle object, just like with drawing tools, allows the user to insert a drawing of a Circle or ellipse shape into a project. When this object is inserted into a project, a window opens to allow the user to setup all available parameters for the Circle object.</p>		<p>The Increment/Decrement Value object is used to add or subtract a value by pressing a button on the Panel. Basically the object uses two Tags, one to read a value from and another to write a modified value to. The Increment/Decrement Value supports numeric Signed Decimal, Unsigned Decimal, BCD, and Floating Point data types with up to 11 digits, including decimal points. The Increment and decrement values are also user selectable.</p>	
<p>The Frame object allows the user to insert a Frame to the project that can be used to Frame other objects. Some of the uses for Frame object include but are not limited to graphically separating objects for different operations that may appear on one screen and emphasizing pushbuttons or other objects that may require more attention by the operator.</p>		<p>The Real Time Graph object displays the value stored in up to two PLC tags, over a history of up to 24 points each. One point is added at each refresh.</p>	
<p>The Pushbutton object is available from the Button Category of the Object List window. The Pushbutton object is an electronic version of a typical Pushbutton normally found on control panels. The Pushbutton object can be used to activate or deactivate components assigned to a Discrete Tag Name.</p>		<p>The Line Graph object displays the values of up to 24 PLC address points. Up to two address arrays can be displayed. The line is drawn in its entirety at each refresh.</p>	
<p>The Switch object is an electronic version of a typical Switch that normally can be found on control panels. The Switch object can be used to activate or deactivate components assigned to a Discrete Tag Name.</p>		<p>The Analog Meter object is used to display the current value of a Tag Name.</p>	
<p>The Indicator Button object is available from the Button Category of the Object List window. The Indicator Button object is an electronic version of a typical Indicator Button normally found on control panels. The Indicator Button is a combination of a Pushbutton and an Indicator Light. The Indicator Button can be used to activate or deactivate components assigned to a Discrete Tag Name.</p>		<p>The Bar Meter object is used to monitor up to two assigned Tag Names continuously. This object has various appearances depending upon the relative value of the tags. The Bar Meter can be used to create digital versions of level, current, and flow meters to name a few samples, or gauges that measure speed and other measurable data.</p>	
<p>The Indicator Light object is an electronic version of a typical Indicator Light normally found on industrial control panels. The Indicator Light can be configured to display the status of the assigned Discrete Tag Name.</p>		<p>The Bitmap Button object offers the ability to use a Bitmap graphic to perform the functions of a Button. This allows users to create their own graphics and implement them within the software project. The Bitmap Button object can be used to activate or deactivate components assigned to a Discrete Tag Name. The C-more Micro-Graphic display only supports two colors, black and white.</p>	
<p>The Graphic Indicator Light object is a more enhanced version of the "Indicator Light Object" that allows the user to choose more detailed graphics to display the status of a tag. This object is an electronic version of a typical Indicator Light normally found on industrial control panels. The Indicator Light can be configured to display the status of the assigned Discrete Tag Name.</p>		<p>The Static Bitmap offers the ability to display a Bitmap graphic on any screen. The Static Bitmap does not change state. Refer to the Dynamic Bitmap Object if you require the graphic object to change state based on a Tag Value in your PLC. The dialog box for a "Static Bitmap" object allows you to "read from disk" and select a graphic file for import. Graphics must be in one of the following formats: .BMP .JWMF .JPG .JPEG</p>	

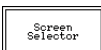
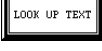
C-more Micro-Graphic Panel Objects continued at top of next page.

Micro-Graphic Programming Software (cont'd)

C-more Micro-Graphic Panel Objects			
Object	Graphic	Object	Graphic
<p>Recipe objects make it easy to make a large number of tag changes with the push of a single button. Create Recipes with up to 99 entries, and multiple sets of values. Then just push a button to load an entire set of values into the group of recipe tags.</p>		<p>The Scroll Text object is available from the Text Category of the Object List window. The Scroll Text object is an electronic version of a marquee. It is similar to the Static Text Object. If the text in the object does not fit in the window, it will scroll from right to left across the window. The Scroll Text object does not require a Tag Name assignment. The Scroll Text Object has a maximum character limit of 128 characters.</p>	
<p>The Dynamic Bitmap object offers the ability to make an object using two different Bitmap graphics that will display one graphic when the Tag is On and a different graphic when the Tag is Off. Use your own bitmap designs or use some of the bitmaps provided with the software that are located in the User Graphic Library.</p>		<p>The Screen Change Pushbutton object is available from the Control Category of the Object List window. The Screen Change Pushbutton object is a pushbutton that can be configured to activate another screen in the project. This object may be edited to various colors and sizes. Users can configure the button to activate the Power-Up screen, Forward Screen, Previous Screen, or any one of the project screens.</p>	
<p>The Static Text object is used to display a Frame with a personalized Message. This Frame and Message can be placed on any screen and any location within the screen.</p>		<p>The Screen Selector object is available from the Control Category of the Object List window. This object is an enhanced version of the Screen Change pushbutton in that it offers many more features and defaults with data from screens in the project. This helps to save time by not having to create Screen change buttons for each screen. This object may be edited to various colors and sizes.</p>	
<p>The Lookup Text object is used to display a Frame with a personalized Message. This Frame and Message can be placed on any screen and any location within the screen. The object is always displayed like a sign but is configured to display only the message prompted by an assigned Tag Name. Messages are retrieved from a Message Database which is configured by the user with text defined by the user. The Lookup Text Object will scroll text up to 128 characters.</p>		<p>The Adjust Display Contrast object is used to allow the operator to adjust the Panel Display Contrast. The default Display setting often works in most applications, however lighting may vary based on the location of each application. In these cases the operator can use this object to make adjustments. The current display setting value will appear on the top of the button and will change as the arrow keys are pressed. This button can be modified to various sizes.</p>	
<p>The Dynamic Text object is used to display text that is retrieved from data stored in a Tag. The Tag Name is assigned to registers in the PLC that contain set character data. The data can be stored in the PLC in ASCII format and may include information such as machine numbers, locations, part numbers, and such. The Message can be configured to be visible (Trigger) when an associated Tag Name is On or Off. This object can be placed on any screen and any location within the screen. The Dynamic Text Object will scroll text up to 40 characters.</p>		<p>The Function object is used to assign the panels function key buttons to a particular action as well as assigning the control of the LED On/Off status. When a button has been assigned as a shift button, the then F1 through F5 will become F6 through F10. The Function Object buttons will activate when the hardware button is pressed or when the object is pressed on the screen. The object size is restricted so that the keys will line up with the hardware function keys on the panel.</p>	

USB to RS-232 Programming Cable Assembly

Using the *C-more* Micro-Graphic Programming Software for project development, the *C-more* 6" Micro-Graphic panel can be connected to a PC (personal computer) by using the USB-to-RS-232 cable assembly, part number EA-MG-PGM-CBL.

- Connect the USB programming cable (included) from a USB port type A on the PC to the USB type B port on the converter (included). Next connect the serial programming cable from the converter's RJ12 port to the panel's RJ12 serial port. The panel receives power from the USB port of the PC that it is connected to through the USB to RS-232 converter assembly.

NOTE: Install *C-more* Micro-Graphic Programming software before connecting the panel to the PC to ensure the panel drivers install correctly.

EA-MG-PGM-CBL

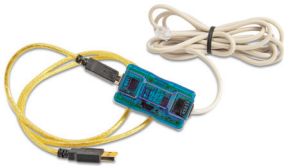

Converter Dimensions

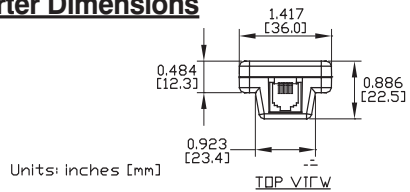

Converter Status LEDs

LED Status Indicators

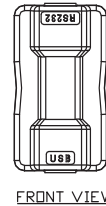
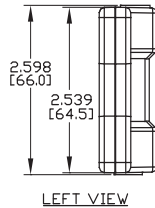
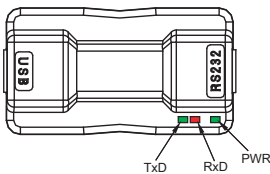

USB Connectivity

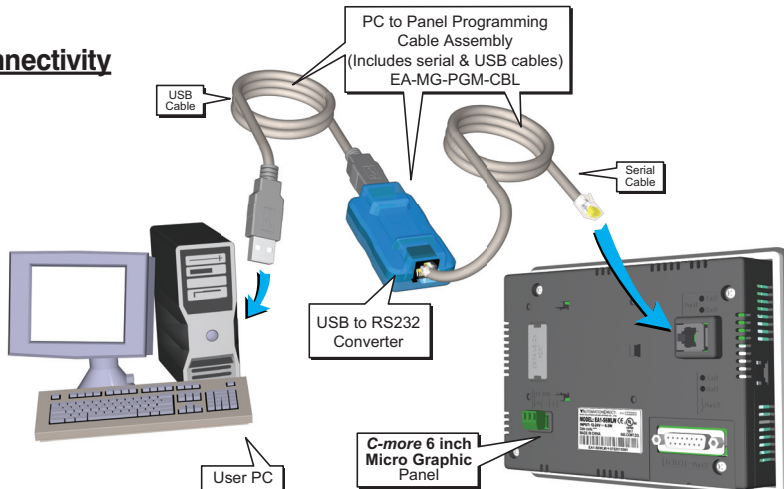

USB to RS-232 Programming Cable Assembly continued at top of next page.

USB to RS232 Programming Cable Assembly (cont'd)

USB to RS232 Converter Specifications	
Part Number:	EA-MG-PGM-CBL
Description:	6-ft. cable assembly to connect personal computer to any C-more Micro-Graphic panel for setup and programming. (Note: This cable assembly uses the PC's USB port and converts the signals to serial transmissions. The USB port supplies 5 VDC to the C-more Micro-Graphic panel for low-power mode configuration operations.) Assembly includes standard USB A-type connector to B-type connector cable, custom converter, and an RS232C cable with RJ12 modular connector on each end.
Hardware:	
• USB Interface	USB Specification Rev. 1.1 Connector: USB Type B jack to accept USB Type B cable plug
• Serial Interface	RS232 (EIA-232-E) Connector: RJ12 phone jack 6p to accept RJ12 cable plug
• Baud Rate	115.2 kbps Maximum
• Input Voltage	5 VDC (Supplied thru serial interface cable.)
• Power Consumption	50 mA (Does not include power to panel and/or bezel.)
Accessory Cables:	
• USB Cable	USB Type A plug to PC on one end, USB Type B plug to converter on other end, 0.30 m [1 foot] length (* Note)
• Serial Cable	RJ12 phone plug connectors on both ends, 2.0 m [6.56 feet] length (* Note)
Environmental:	
• Operating Temperature	0 to 50 °C (32 to 122 °F)
• Storage Temperature	-20 to 60 °C (-4 to 140 °F)
• Humidity	5 to 95 % RH (non-condensing)
• Environmental air	No corrosive gases permitted
• Vibration	IEC60068-2-6 (Test Fc), 5-9 Hz: 3.5 mm amplitude, 9-150 Hz: 1.0G, sweeping, at a rate of 1 octave/min. (±10%), 10 sweep cycles per axis on each of 3 mutually perpendicular axes
• Shock	IEC60068-2-27 (Test Ea), 15 G peak, 11 ms duration, three shocks in each direction per axis, on 3 mutually perpendicular axes (total of 18 shocks)
Physical:	
• Dimensions	2.559" (W) x 1.417" (H) x 0.886" (D) [65.0 mm x 36.0 mm x 22.5 mm]
• Weight	1.06 oz. [30 g]
* Note: Maximum cable length for either the USB or serial cable should not exceed 2.0 m [6.56 feet] in length.	

20-Button Landscape (Horizontal) Keypad Bezel

The 20-button keypad bezel is designed to be used with the *C-more* 6" Micro-Graphic panels. The keypad includes four directional arrow cursor buttons, a full numeric keypad, and one each of an ESCAPE, MENU, CLEAR and ENTER button. The keypad is intended to be used with the numeric entry object to allow changing of a value, and can also be used to navigate & select screen objects. The numeric buttons can be used to enter a new value, or use the cursor left and right buttons to select a digit and the cursor up and down buttons to change the value, along with the ENTER and CLEAR buttons. It can also be used to access and navigate the screen selector feature. The keypad bezel is designed for easy drop-in of a *C-more* 6" Micro-Graphic panel. No panel configuration is required.

EA-MG6-BZ2



Dimensions

Units Inches [mm]

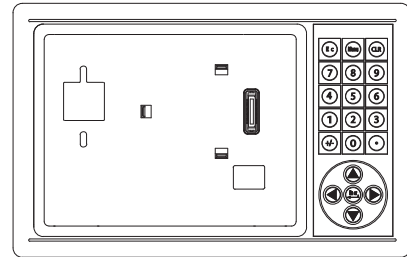
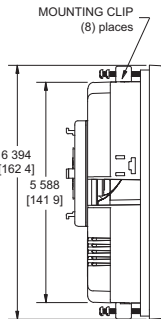
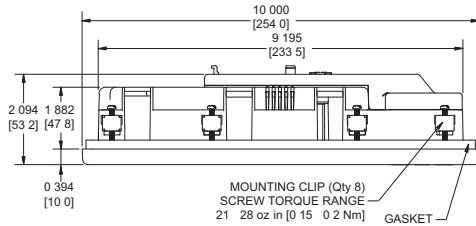

Panel Cutout

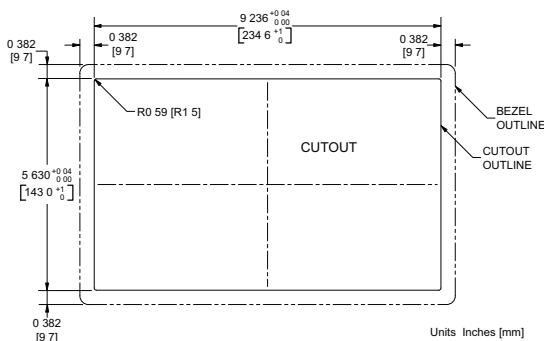

Four directional cursor buttons, numeric buttons and ESC, MENU, CLEAR and ENTER buttons.

Panel Thickness

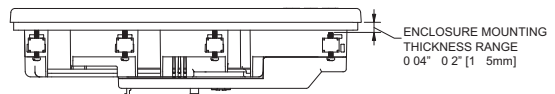

20-Button Keypad Bezel continued at top of next page.

20-Button Landscape (Horizontal) Keypad Bezel (cont'd)

20-Button Keypad Bezel Specifications	
Part Number:	EA-MG6-BZ2
General:	
• Micro-Graphic Panels Supported	EA-S6ML, EA-S6MLW
• Connection	Connects with expansion connector on the rear of the C-more 6" Micro-Graphic panel.
• Power Consumption	None
• Keypad Button Life	Minimum of 500,000 cycles
• Enclosure Mounting	(8) mounting clips, EA-MG-BZ2-BRK, included.
	Note: The C-more 6" Micro-Graphic panel is installed into the keypad bezel using the (4) mounting clips, EA-MG-BZ2-BRK, that are supplied with the panel.
Environmental:	
• Operating Temperature	0 to 50 °C (32 to 122 °F)
• Storage Temperature	-20 to 60 °C (-4 to 140 °F)
• Humidity	5 to 95 % RH (non-condensing)
• Environmental air	No corrosive gases permitted
• Vibration	IEC60068-2-6 (Test Fc), 5-9 Hz: 3.5 mm amplitude, 9-150 Hz: 1.0G, sweeping, at a rate of 1 octave/min. (±10%), 10 sweep cycles per axis on each of 3 mutually perpendicular axes
• Shock	IEC60068-2-27 (Test Ea), 15 G peak, 11 ms duration, three shocks in each direction per axis, on 3 mutually perpendicular axes (total of 18 shocks)
• Noise Immunity	NEMA ICS3-304 RFI, (145 MHz, 440 MHz 10 W @ 10 cm) Impulse 1000 V @ 1 µs pulse
• Enclosure	NEMA 4/4X, IP-65 (When mounted correctly, for indoor use only.)
• Agency Approvals	CE (EN61131-2), UL508, CUL Canadian C22.2 No. 142-M95, UL File E157382
Physical:	
• Dimensions	10.000" (W) x 6.394" (H) x 2.488" (D) [254.0 mm x 162.4 mm x 63.2 mm]
• Weight	26.1 oz. [740 g]

*C-more 6" Micro Graphic Panel
being installed in a 20 button
Keypad bezel EA-MG6-BZ2*



20-Button Keypad Bezel continued at top of next page.

20-Button Horizontal (Landscape) Keypad Bezel (cont'd)

Panel and 20-Button Keypad Bezel Assembly

3

2. Use the (4) Panel Mounting Clips, EA MG BZ2 BRK, that are supplied with the panel, to secure panel to keypad bezel and compress the gasket between the panel and the keypad bezel. Tighten screws to a torque of 21 28 oz in [0.15 0.2 Nm].

3. Use (8) Bezel Mounting Clips, EA MG BZ2 BRK, to secure keypad bezel through enclosure cutout. Tighten screws to a torque of 21 28 oz in [0.15 0.2 Nm].

1. Remove Expansion Connector Protective Cover from rear of panel.

4. Peel Protective Film from front of panel.

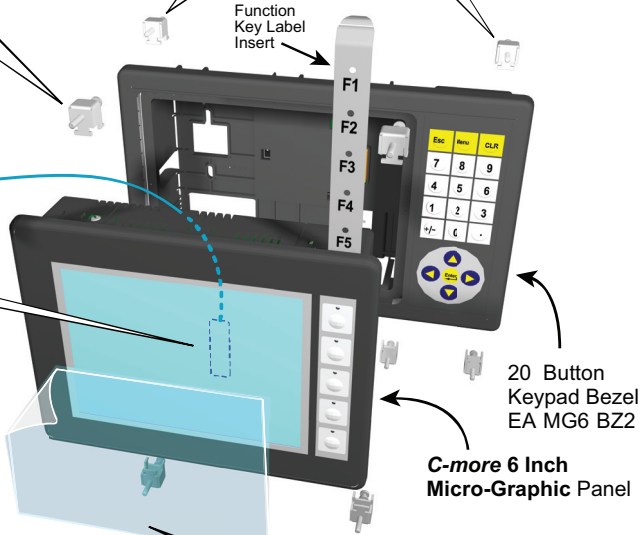

NOTE: Mounting clips for the panel and keypad bezels are included with the respective product.

21-Button Portrait (Vertical) Keypad Bezel

The 21-button keypad bezel is designed to be used with the *C-more* 6" Micro-Graphic panels. The keypad includes four directional arrow cursor buttons, a full numeric keypad, and one each of an ESCAPE, MENU, CLEAR and two ENTER buttons. The keypad is intended to be used with the numeric entry object to allow changing of a value, and can also be used to navigate & select screen objects. The numeric buttons can be used to enter a new value, or use the cursor left and right buttons to select a digit and the cursor up and down buttons to change the value, along with the ENTER and CLEAR buttons. It can also be used to access and navigate the screen selector feature. The keypad bezel is designed for easy drop-in of a *C-more* 6" Micro-Graphic panel. No panel configuration is required.

EA-MG6-BZ2P



Dimensions

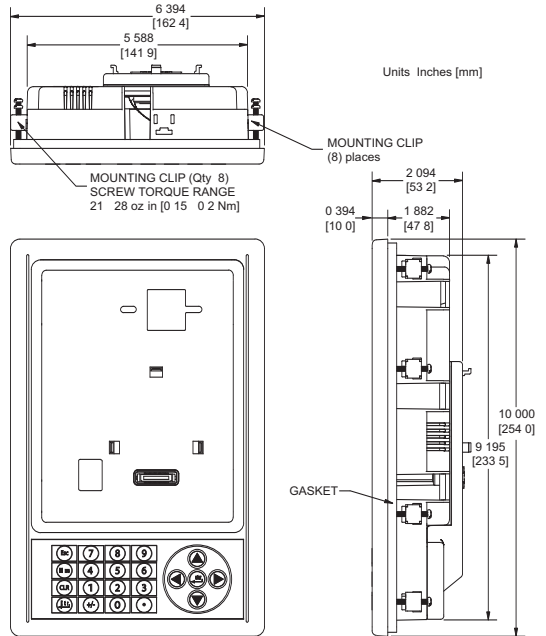

Panel Cutout

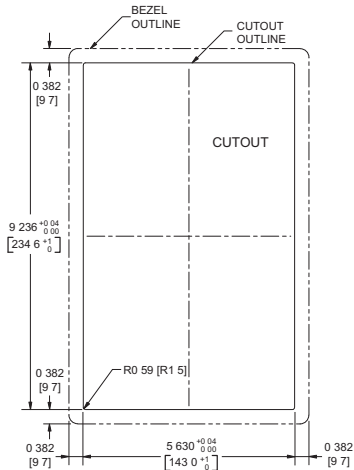

Four directional cursor buttons, numeric buttons, and ESC, MENU, CLEAR and two ENTER buttons.

Panel Thickness

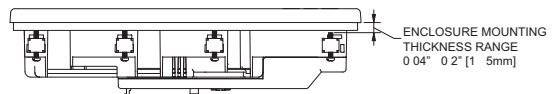

21-Button Keypad Bezel continued at top of next page.

21-Button Vertical (Portrait) Keypad Bezel (cont'd)

21-Button Keypad Bezel Specifications	
Part Number:	EA-MG6-BZ2P
General:	
• Micro-Graphic Panels Supported	EA-S6ML, EA-S6MLW
• Connection	Connects with expansion connector on the rear of the C-more 6" Micro-Graphic panel.
• Power Consumption	None
• Keypad Button Life	Minimum of 500,000 cycles
• Enclosure Mounting	(8) mounting clips, EA-MG-BZ2-BRK, included.
	Note: The C-more 6" Micro-Graphic panel is installed into the keypad bezel using the (4) mounting clips, EA-MG-BZ2-BRK, that are supplied with the panel.
Environmental:	
• Operating Temperature	0 to 50 °C (32 to 122 °F)
• Storage Temperature	-20 to 60 °C (-4 to 140 °F)
• Humidity	5 to 95 % RH (non-condensing)
• Environmental air	No corrosive gases permitted
• Vibration	IEC60068-2-6 (Test Fc), 5-9 Hz: 3.5 mm amplitude, 9-150 Hz: 1.0G, sweeping, at a rate of 1 octave/min. (±10%), 10 sweep cycles per axis on each of 3 mutually perpendicular axes
• Shock	IEC60068-2-27 (Test Ea), 15 G peak, 11 ms duration, three shocks in each direction per axis, on 3 mutually perpendicular axes (total of 18 shocks)
• Noise Immunity	NEMA ICS3-304 RFI, (145 MHz, 440 Mhz 10 W @ 10 cm) Impulse 1000 V @ 1 µs pulse
• Enclosure	NEMA 4/4X, IP-65 (When mounted correctly, for indoor use only.)
• Agency Approvals	CE (EN61131-2), UL508, CUL Canadian C22.2 No. 142-M95, UL File E157382
Physical:	
• Dimensions	6.394" (W) x 10.000" (H) x 2.488" (D) [162.4 mm x 254.0 mm x 63.2 mm]
• Weight	26.1 oz. [740 g]

*C-more 6" Micro Graphic Panel
installed in a 21 button Keypad
bezel EA-MG6-BZ2P*



21-Button Keypad Bezel continued at top of next page.

21-Button Vertical (Portrait) Keypad Bezel (cont'd)

Panel and 21-Button Keypad Bezel Assembly

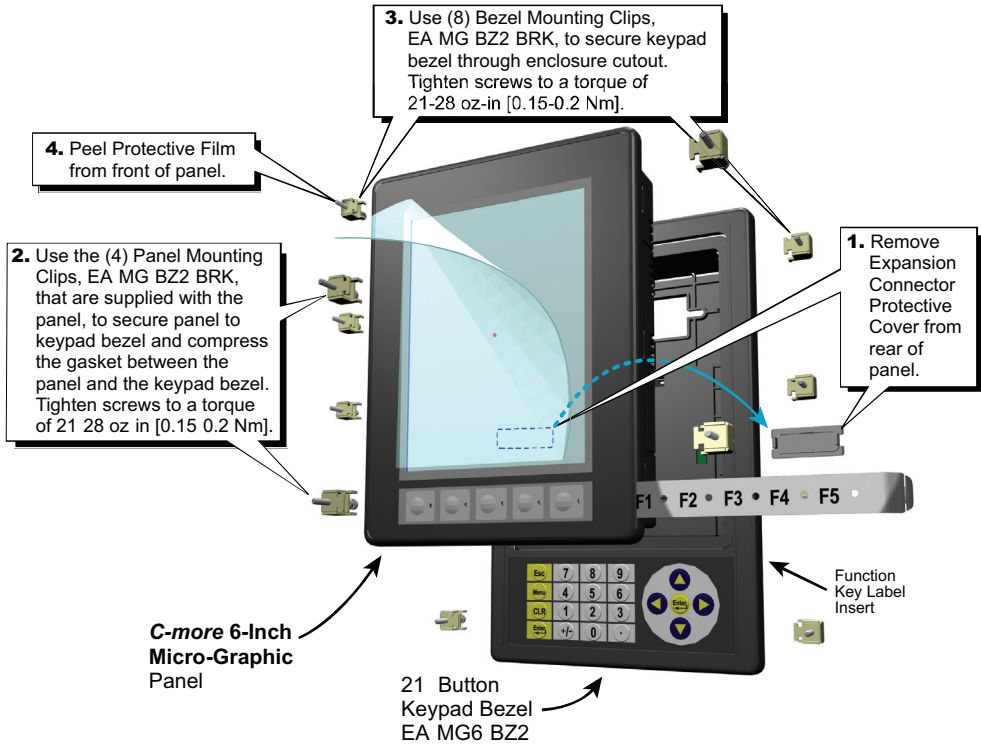

NOTE: Mounting clips for the panel and keypad bezels are included with the respective product.

D-SUB 15-pin 90-degree Communication Port Adapter

The EA-ADPTR-4 adapter plugs into the 15-pin serial port on the rear of the 6” panel to allow a PLC communication cable to be plugged in at a 90 degree angle to reduce panel depth requirements. 15-pin straight through pin-out. UL Recognized.

EA-ADPTR-4

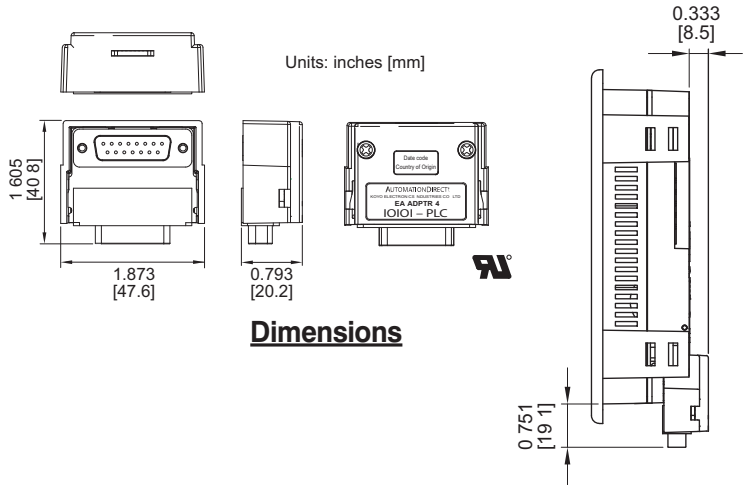

Dimensions

D-SUB 15-pin to Terminal Block Adapter

The EA-COMCON-3 adapter plugs into the 15-pin serial port on the rear of the 6” panel to allow wire terminal connections for an RS-422/RS-485/DH-485 PLC communication cable. UL Recognized.

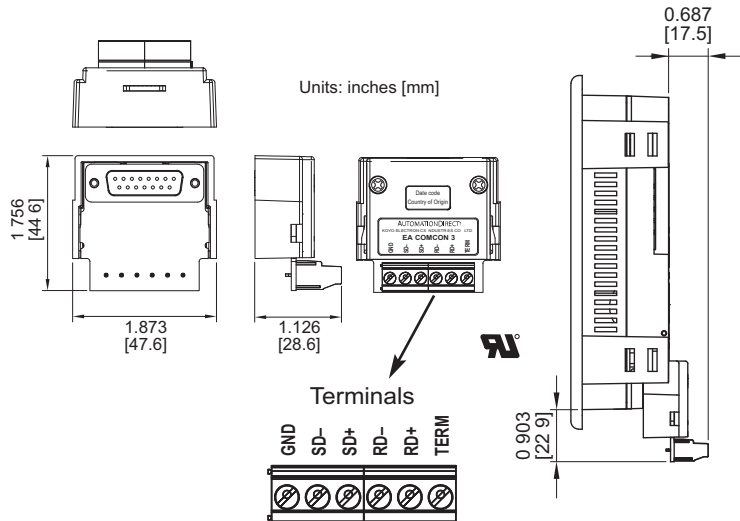

Clear Screen Overlay

Optional clear screen overlay used to protect *C-more* Micro-Graphic displays from minor scratches and wear. Package contains three clear screen overlays.

EA-6-COV2

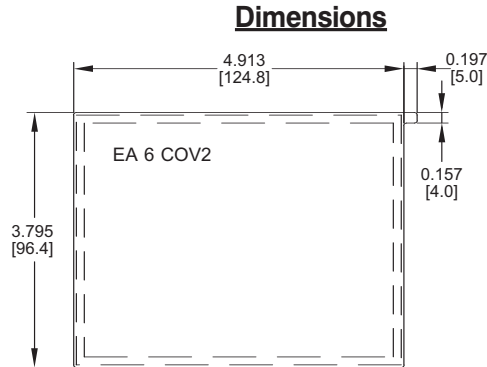
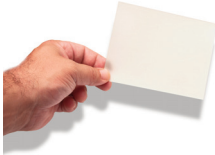

Clear Screen Overlay Installation

Step 1



Remove the overlay from the package

Step 2



Remove the paper backing from the overlay

Step 3



Align the overlay with the screen and press the adhesive firmly into place

Step 4



Remove the protective film*



***NOTE:** The protective cover ships with a thin protective sheet on the face of the cover that needs to be carefully removed. If your panel is not clear, the protective sheet may not have been removed.

INSTALLATION & WIRING



In This Chapter...

Safety Guidelines	4-2
Introduction	4-3
Panel Cutout Dimensions (all models)	4-4
Wiring Guidelines	4-5

Safety Guidelines



NOTE: *Products with CE marks perform their required functions safely and adhere to relevant standards as specified by CE directives provided they are used according to their intended purpose and that the instructions in this manual are adhered to. The protection provided by the equipment may be impaired if this equipment is used in a manner not specified in this manual. A listing of our international affiliates is available on our Web site: <http://www.automationdirect.com>*

4



WARNING: Providing a safe operating environment for personnel and equipment is your responsibility and should be your primary goal during system planning and installation. Automation systems can fail and may result in situations that can cause serious injury to personnel or damage to equipment. Do not rely on the automation system alone to provide a safe operating environment. You should use external electromechanical devices, such as relays or limit switches, that are independent of the PLC application to provide protection for any part of the system that may cause personal injury or damage. Every automation application is different, so there may be special requirements for your particular application. Make sure you follow all national, state, and local government requirements for the proper installation and use of your equipment.

Plan for Safety

The best way to provide a safe operating environment is to make personnel and equipment safety part of the planning process. You should examine *every* aspect of the system to determine which areas are critical to operator or machine safety. If you are not familiar with control system installation practices, or your company does not have established installation guidelines, you should obtain additional information from the following sources.

- NEMA — The National Electrical Manufacturers Association, located in Washington, D.C. publishes many different documents that discuss standards for industrial control systems. You can order these publications directly from NEMA. Some of these include:

ICS 1, General Standards for Industrial Control and Systems

ICS 3, Industrial Systems

ICS 6, Enclosures for Industrial Control Systems

- NEC — The National Electrical Code provides regulations concerning the installation and use of various types of electrical equipment. Copies of the NEC Handbook can often be obtained from your local electrical equipment distributor or your local library.
- Local and State Agencies — many local governments and state governments have additional requirements above and beyond those described in the NEC Handbook. Check with your local Electrical Inspector or Fire Marshall office for information.

Introduction

The installation and wiring of *C-more* 6" Micro-Graphic panels require selecting an appropriate location for the panel, laying out the cutout dimensions on the surface of the control cabinet that the panel will be mounted through, securing the panel with the provided mounting clips, tightening the screws to the appropriate torque rating to assure the gasket is sealing correctly, and finally connecting the appropriate power source to the panel.



NOTE: Each *C-more* 6" Micro-Graphic panel is provided with a cutout template to simplify marking the proper cutout size on the surface of the control cabinet that the panel will be mounted through. The keypad bezels are also provided with an appropriate cutout template for mounting convenience.

The *C-more* 6" Micro-Graphic panels include four mounting clips. They are fitted to the panel by inserting two tabs into mating slots on the panel and then sliding the clip into a narrower slot to secure it in place.

If using the panel with a Keypad Bezel, then install the panel into the keypad bezel and secure with the mounting clips that are provided with the panel to seal the panel gasket. Create a cutout in the enclosure that the assembled panel and keypad bezel will be mounted through and secure the assembly with the mounting clips that are provided with the keypad bezel. See **Chapter 3: Accessories** for additional details.

Mounting Clips EA-MG-BZ2-BRK

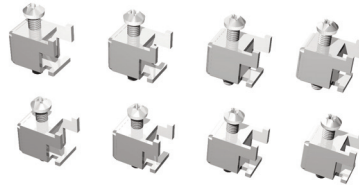

NOTE: The *C-more* 6" Micro-Graphic panel (EA1-S6ML & EA1-S6MLW), 20-Button Keypad Bezel (EA-MG6-BZ2) and 21-Button Keypad Bezel (EA-MG6-BZ2P) use the same type of mounting clip (EA-MG-BZ2-BRK).

Panel Cutout Dimensions (all models)

The *C-more* 6" Micro-Graphic panel is mounted into a cutout through the control cabinet and secured with four (4) mounting clips. The mounting clips are provided with the panel. There are slots on each side of the panel's long dimension that the two tabs on each mounting clip will match. The mounting clips are held in place by inserting the tabs into the "T" shaped holes (slots) and then moving the mounting clip toward the rear of the panel to keep it in place. Next tighten the mounting clip screws to pull the rear of the panel's bezel to the control cabinet's mounting surface. The screws need to be tightened to the torque rating shown in the illustration below so that the gasket is compressed to form the proper seal between the panel and cabinet surface.

4

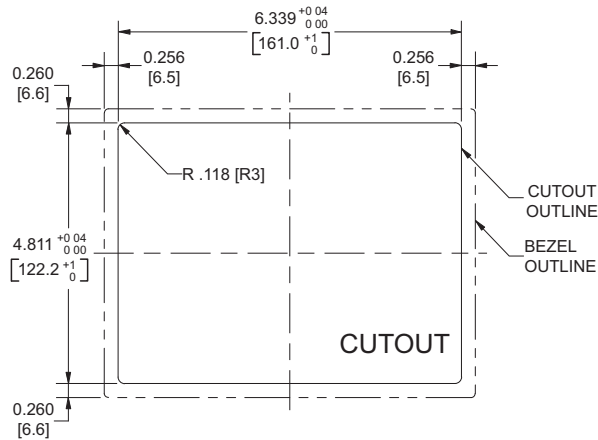

Enclosure Mounting Thickness Ranges and Mounting Bracket Screw Torque

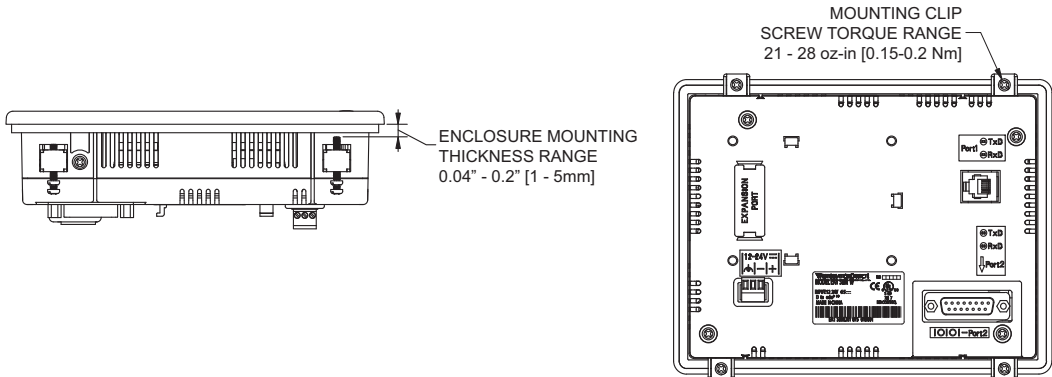

Wiring Guidelines



WARNING: To minimize the risk of potential safety problems, you should follow all applicable local and national codes that regulate the installation and operation of your equipment. These codes vary from area to area and it is your responsibility to determine which codes should be followed, and to verify that the equipment, installation, and operation are in compliance with the latest revision of these codes. Equipment damage or serious injury to personnel can result from the failure to follow all applicable codes and standards. We do not guarantee the products described in this publication are suitable for your particular application, nor do we assume any responsibility for your product design, installation, or operation.

If you have any questions concerning the installation or operation of this equipment, or if you need additional information, please call us at 1-800-633-0405 or 770-844-4200.

This publication is based on information that was available at the time it was printed. At AutomationDirect.com® we constantly strive to improve our products and services, so we reserve the right to make changes to the products and/or publications at any time without notice and without obligation. This publication may also discuss features that may not be available in certain revisions of the product.

Providing Power to the *C-more* 6" Micro-Graphic Panel

Power can be supplied to the *C-more* Micro-Graphic panel in one of three different ways.

- 1.) The *C-more* 6" Micro-Graphic panel is powered during programming from the PC through the USB to RS-232 Programming Cable Assembly, EA-MG-PGM-CBL. The panel will operate in Low-Power mode when powered by the PC and result in a dim screen.
- 2.) During operation, the 6" panel functions in High-Power Mode when supplied powered by a minimum 1 Amp 12 - 24 VDC power source. Recommended power supplies are AutomationDirect part number PSP24-024S or PSP24-024C.
- 3.) During operation, the *C-more* 6" Micro-Graphic panel can function in Low-Power Mode powered from most *AutomationDirect* PLC's RJ12 serial communications port. Use a DV-1000CBL communications cable, or a DV-1000CBL communications cable with a FA-15HD 15-pin HD DSub/RJ12 Adapter connected to most AutomationDirect PLC's 15-pin HD communications port (DL06, D2-250-1 & D2-260) PLCs for Low-Power operation. See **Chapter 6: PLC Communications** for additional details. The panel will operate in low-power mode when powered by the PC.



NOTE: When the 6" panel is powered through Port1 from a connected PLC or PC, the screen brightness is diminished because the panel is running in **Low-Power Mode**. For full brightness, connect an external 12-24 VDC power source to the panel's power connection. **Low-Power Mode** is intended for initial programming. For full brightness, connect an external 12-24 VDC power source when the panel is installed in its application.

Wiring Guidelines continued at top of the next page.

Wiring Guidelines (cont'd)

Panel Powered from AutomationDirect PLC via Communications Cable

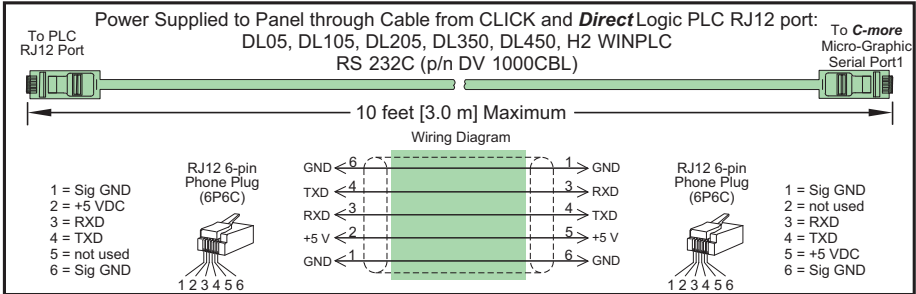

NOTE: Maximum cable length when the panel is powered via a PLC is 10 feet.

NOTE: Only one C-more Micro-Graphic panel can be powered by a CLICK PLC. If a 2nd panel is connected to a different port on the CLICK PLC, an external power supply is required.

Wiring Guidelines continued at top of the next page.

Wiring Guidelines (cont'd)

Panel Powered from an external DC Power Supply – Wiring Diagrams

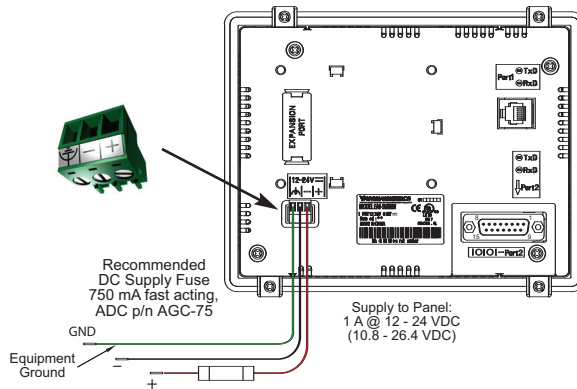

NOTE: Recommended DC power supply, **AutomationDirect** Part No. PSP24-024S or PSP24-024C.

Maximum communication cable length when powered from an external DC Power Adapter

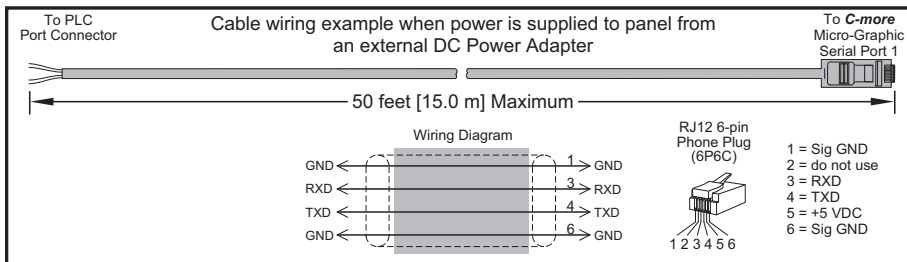

NOTE: When the 6" panel is powered through Port1 from a connected PLC or PC, the screen brightness is diminished because the panel is running in **Low-Power Mode**. For full brightness, connect an external 12-24 VDC power source to the panel's power connection. **Low-Power Mode** is intended for initial programming. For full brightness, connect an external 12-24 VDC power source when the panel is installed in its application.

SYSTEM SETUP SCREENS



In This Chapter...

Introduction	5-2
Accessing the System Setup Screens	5-3
System Setup Screens Flowchart	5-4
Setup Menu	5-5
Information Menu	5-6
Memory	5-6
Protocol	5-6
Extensions	5-6
Versions	5-6
Setting Menu	5-7
LCD Contrast	5-7
Backlight, Model EA1-S6ML	5-8
Backlight, Model EA1-S6MLW	5-9
Beep	5-10
Calibration	5-11
Clear User Memory	5-12
Reset to Factory Default	5-12
Hourglass	5-13
Rotation	5-14
Test Menu	5-15
Serial Port1 - Loop Back Test	5-15
Serial Port2 - Loop Back Test	5-16
PLC Enquiry Test	5-17
Buzzer Test	5-17
Touch Panel Test	5-18
Exit	5-18

Introduction

The *C-more*[®] Micro-Graphic panels include a series of built-in **System Setup Screens** that allow the user to view detailed information about the panel, adjust features, test various functions of the panel, clear memory, and reset all values and conditions back to the original factory defaults.

The following is presented to give the user a detailed step by step look at:

- How to access the System Setup Screens
- What adjustments and features are available
- When and why the feature may need to be adjusted or used
- How to adjust and/or interrupt the features

The System Setup Screens are split into three categories to make it easy for the user to view information, make adjustments, or test the panel. The three Setup Menu selections are:

Information

Here you will find detailed information about the panel's available memory and usage, the protocol being used by the panel, if an optional keypad bezel is installed and version information for the firmware and boot loader.

Setting

This is the area for adjusting the contrast of the display, selecting one of the five backlight colors (red, amber, yellow, lime or green for EA1-S6ML or white, pink1, pink2, pink3 or red for EA1-S6MLW), enabling or disabling the internal beeper, calibrating the touch panel, clearing the user memory, resetting all of the settings back to the factory defaults, and setting the loading screen hourglass icon delay time or disabling the display of the hourglass icon.

The Setting factory default values are:

- LCD Contrast value of 8
- Green backlight color for EA1-S6ML, white backlight color for EA1-S6MLW
- The internal audible beeper enabled
- Forced touch panel calibration
- User program cleared from memory
- Hourglass icon delay of 350 ms.
- Horizontal orientation

Test Menu

The test menu includes options to initiate communication tests of the two serial ports, to test communications with the PLC, to test operation of the panel's beeper and to test the touch panel surface. Refer to the serial port 1 and serial port 2 loop back test sections of this chapter for details on loop back connector wiring.

Accessing the System Setup Screens

To access the Setup Menu of the panel System Setup Screens, press the panel's BAK [F1] and ENT [F5] function keys simultaneously for three (3) seconds as shown below. The System Setup Screens' Setup Menu will be displayed as shown at the bottom of this page.

Press both the F1 and F5 function keys simultaneously for 3 seconds to bring up the System Setup Screens' Setup Menu.

C-more 6" Micro-Graphic Panel

5



System Setup Screens Flowchart

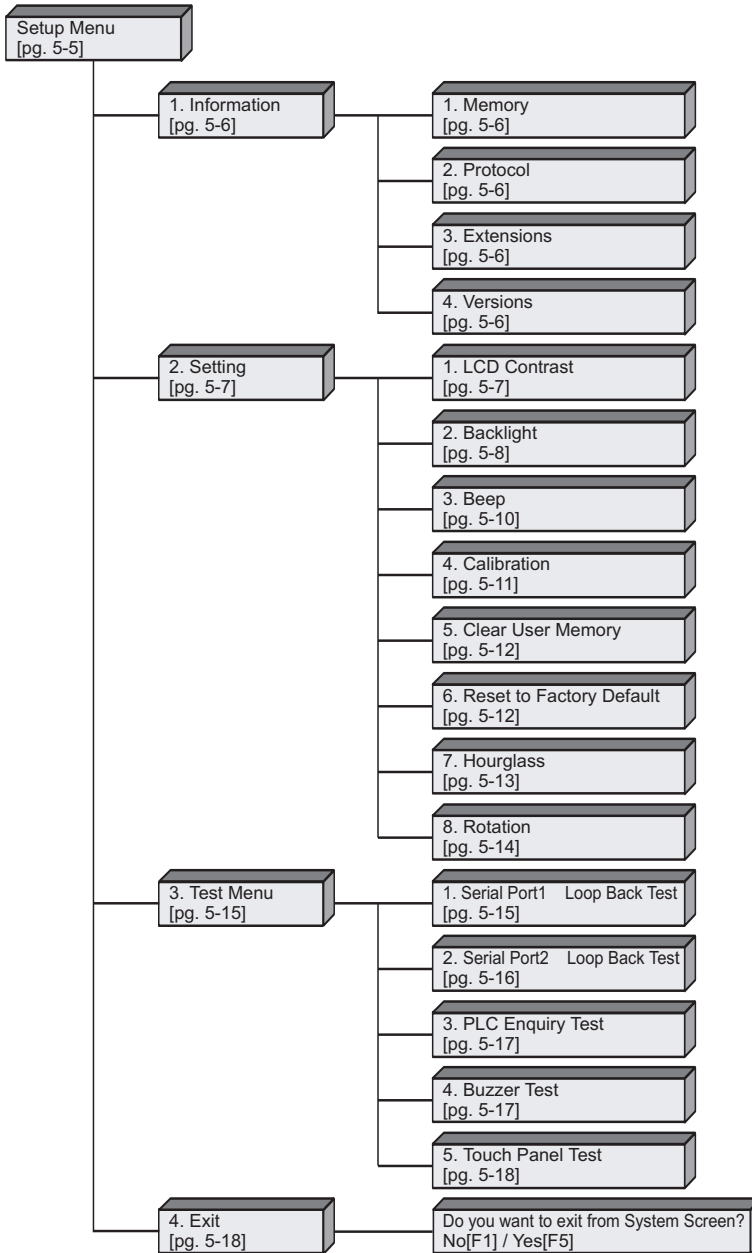

Setup Menu

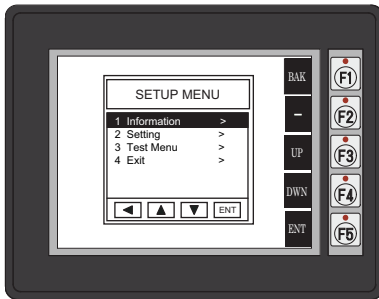

To navigate the different selections under the Setup Menu, use the function keys BAK [F1] to return to the project screen or previous screen, UP [F3] to cursor up, DWN [F4] to cursor down, and ENT [F5] to enter a selection.

Pressing ENT [F5] with **Information** highlighted will take you to the **Information** menu screen. See page 5-6.

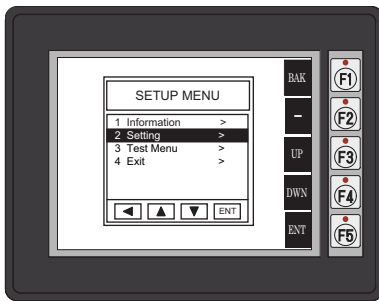

Pressing ENT [F5] with **Setting** highlighted will take you to the **Setting** menu screen. See page 5-7.

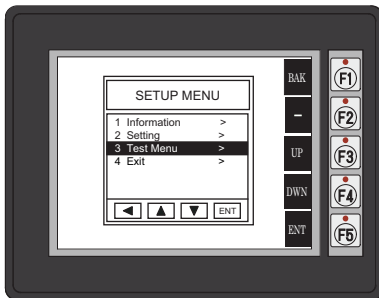

Pressing ENT [F5] with **Test Menu** highlighted will take you to the **Test Menu** screen. See page 5-15.

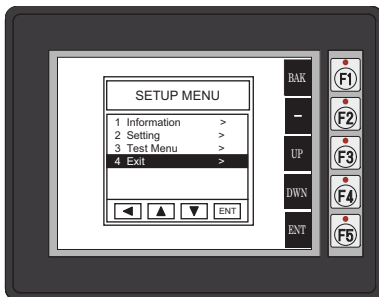

Pressing ENT [F5] with **Exit** highlighted will allow the user to be decided whether to **Exit** or not **Exit** the System Setup Screens. See page 5-18.

Information Menu

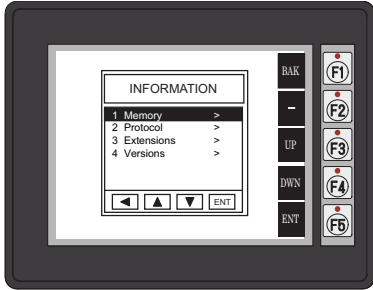

Pressing ENT [F5] with **Memory** highlighted will show the total memory available, memory usage and free memory available for the project.

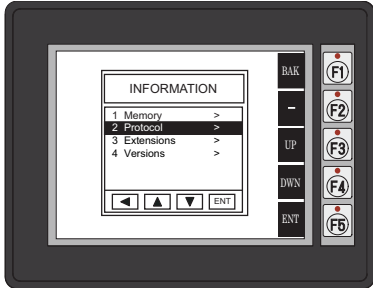
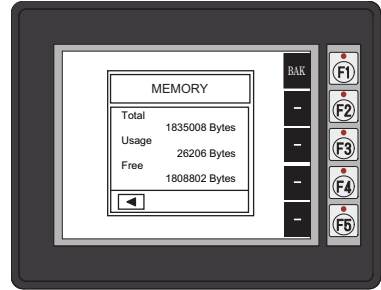

Pressing ENT [F5] with **Protocol** highlighted will show the PLC Protocol that has been assigned to the panel and the protocol version.

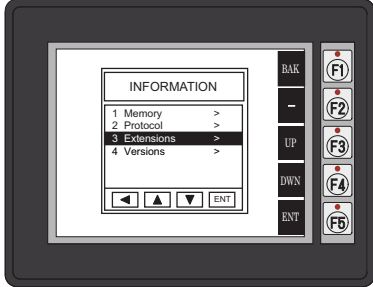
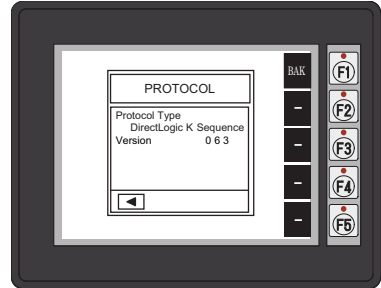

Pressing ENT [F5] with **Extensions** highlighted will show if an optional keypad bezel is installed on the panel. The example here shows the EA-MG6-BZ2.

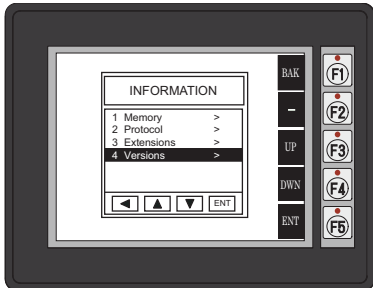
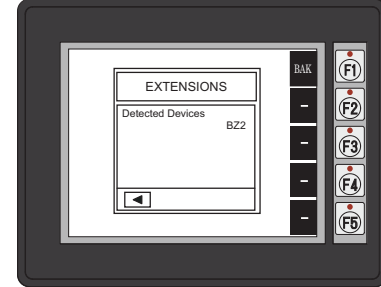

Pressing ENT [F5] with **Versions** highlighted will show the panel's firmware and boot loader versions.*

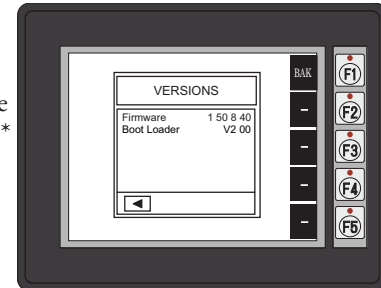

5



***Note:** Firmware Version 2.0 or later is required with models EA1-S6ML and EA1-S6MLW. Available for free download at www.automationdirect.com

Setting Menu

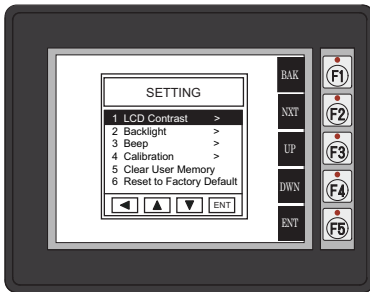

Use the UP [F3] and DWN [F4] function keys to scroll through the list of settings. There are six selections on the first screen and two additional selections on a second screen. You can also use the NXT [F2] function key to go back and forth between the two screens without having to use the up and down keys. The BAK [F1] function key will return you to the previous screen. Use the ENT [F5] function key to make your selection once you have the setting highlighted.

The **Setting** screen includes the following:

LCD Contrast - page 5-7

Backlight – page 5-8 to 5-9

Beep – page 5-10

Calibration – page 5-11

Clear User Memory – page 5-12

Reset to Factory Default – page 5-12

Hourglass – page 5-13

Rotation – page 5-14

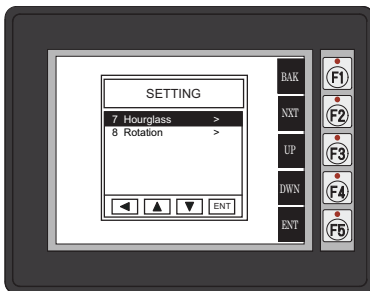

Setting – LCD Contrast

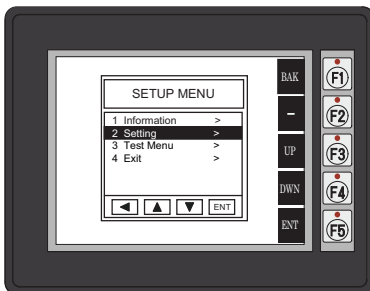

With **LCD Contrast** highlighted, press ENT [F5] to bring up the screen showing the current value. The default is 8. The contrast can be adjusted between 1 and 16, with 1 being the least contrast and 16 being the greatest.

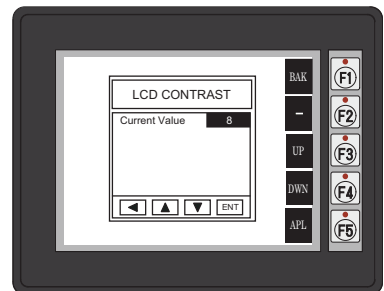

NOTE: When the panel is powered through Port1 from a connected PLC or PC, the screen brightness is diminished because the panel is running in **Low-Power Mode**. For full brightness, connect an external 12-24 VDC power source to the panel's power connection. **Low-Power Mode** is intended for initial programming. For full brightness, connect an external 12-24 VDC power source when the panel is installed in its application.

Setting – Backlight, Model EA1-S6ML

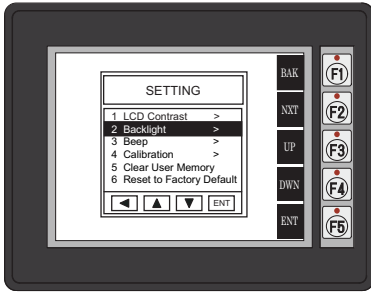

With Backlight highlighted, press ENT [F5] to show the current backlight screen color. For model EA1-S6ML, the default is green. The UP [F3] and DWN [F4] function keys can be used to scroll through the five available backlight colors (green, lime, yellow, amber and red). Use the APL [F5] function key to apply the new color. Shown here are the various backlight colors.

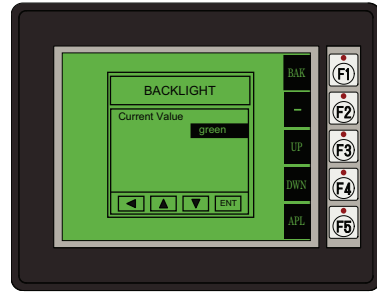

Green

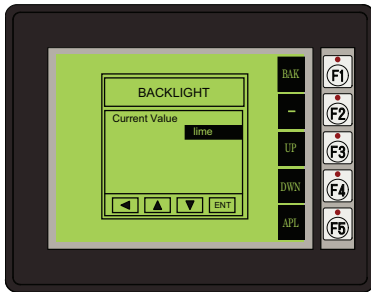

Lime

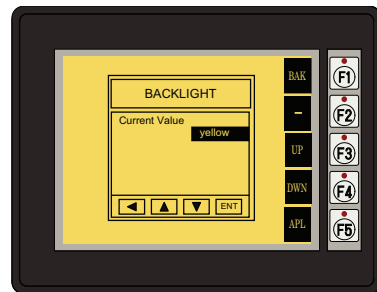

Yellow

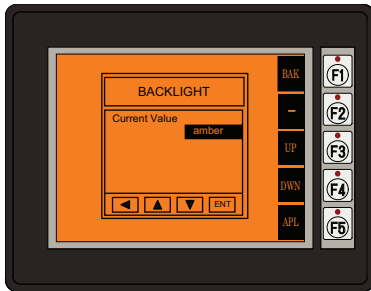

Amber

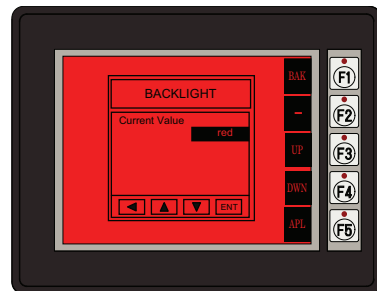

Red



Note: Loading a project to the panel will override whatever color is chosen from the System Setup Screens' Backlight color selection screen. The selected color is displayed only when in the System Setup Screens.

Setting – Backlight, Model EA1-S6MLW

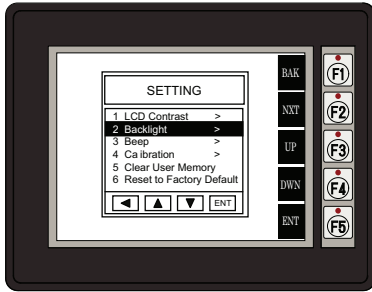

With Backlight highlighted, press ENT [F5] to show the current backlight screen color. For model EA1-S6MLW, the default is white. The UP [F3] and DWN [F4] function keys can be used to scroll through the five available backlight colors (white, pink1, pink2, pink3 and red). Use the APL [F5] function key to apply the new color. Shown here are the various backlight colors.

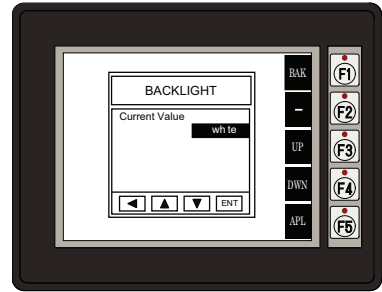

White

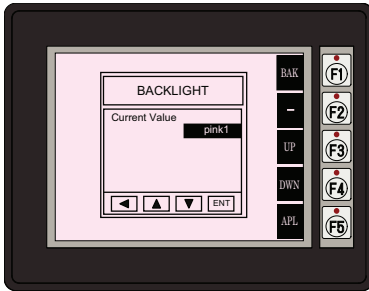

Pink1

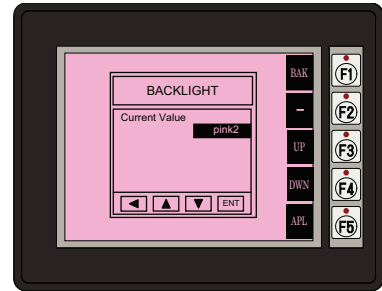

Pink2

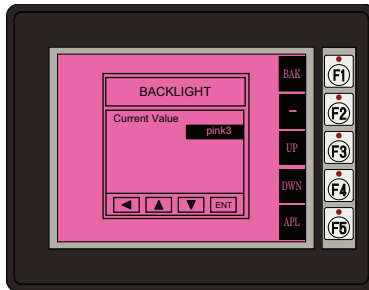

Pink3

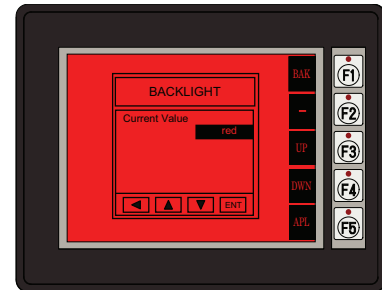

Red



Note: Loading a project to the panel will override whatever color is chosen from the System Setup Screens' Backlight color selection screen. The selected color is displayed only when in the System Setup Screens.

Setting – Beep

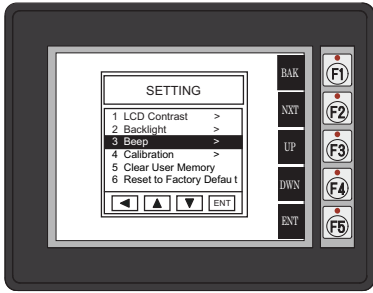

With Beep highlighted, press ENT [F5] to show the current value for the internal beeper. The default is ON. The UP [F3] and DWN [F4] function keys can be used to toggle between the ON and OFF state for the beeper (enable or disable). Use the APL [F5] function key to apply the selection.

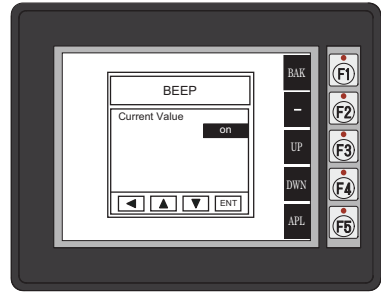

5



Note: Loading a project to the panel will override whatever selection is chosen for the beeper from the System Setup Screens' Beep on/off selection screen. The Beep on/off choice can be changed through the System Setup Screens **after** a project is loaded.



Note: When the panel is powered through Port1 from a connected PLC or PC, the beep will not function properly because the panel is running in **Low-power mode**. To use the beep signal, power the panel from an external 12-24 VDC power source.

Setting – Calibration

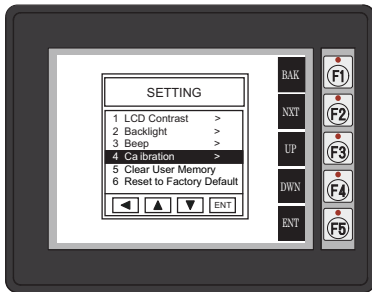

With **Calibration** highlighted, press ENT [F5] to bring up the first calibration screen as shown on the right. Touch the “cross” in the upper left corner as accurately as you can. When the screen is touched, the cross will move to each corner and finally to the center of the screen. If the touch points are within the built-in calibration tolerance, the final screen will allow you to either save and quit from the calibration procedure, or allow you to retry. If the points that were touched are not within the calibration tolerance, you will be returned to the first calibration screen and will need to start over.

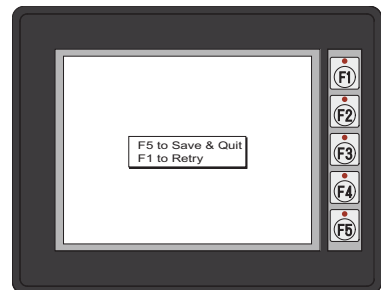
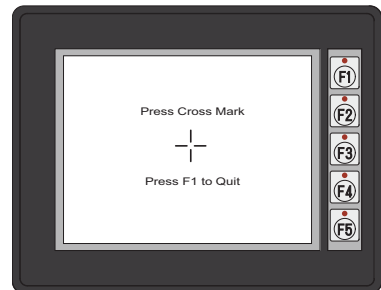
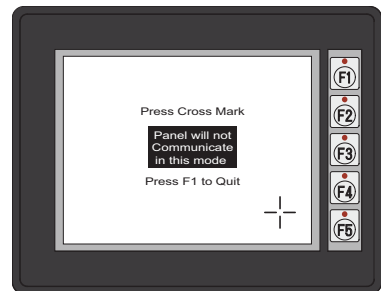
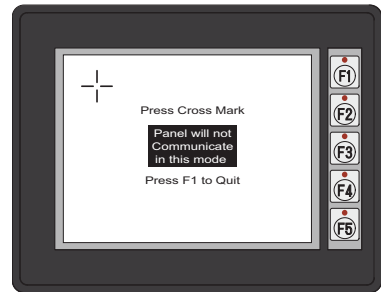

5

Setting – Clear User Memory

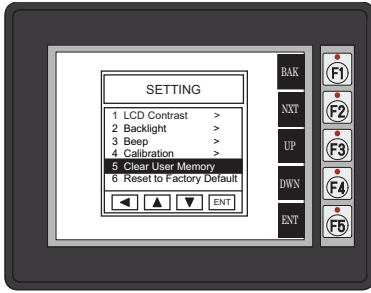

With Clear User Memory highlighted, press ENT [F5]. You will be given the choice to either proceed with clearing the user memory by pressing [F5] for YES or allowed to cancel by pressing [F1] for NO.

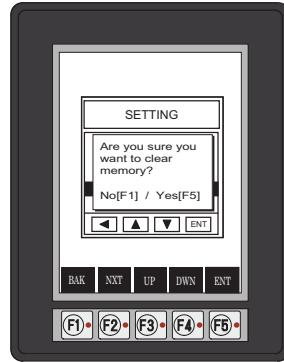
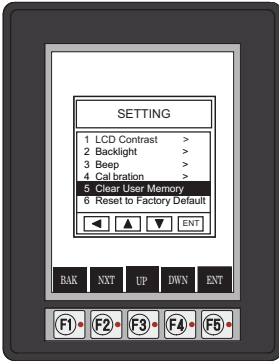
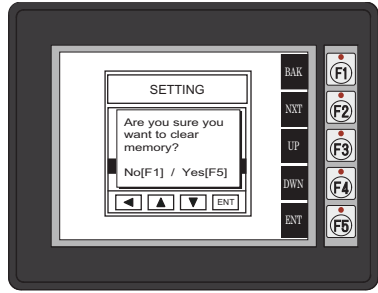

Setting – Reset to Factory Default

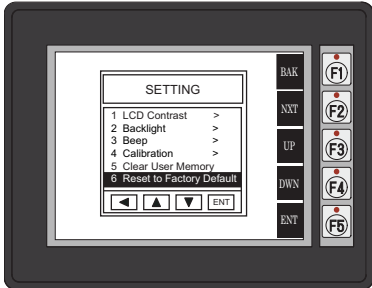

With Reset to Factory Default highlighted, press ENT [F5]. Press [F5] to restore all settings to factory defaults and clear user memory. Press [F1] to cancel.

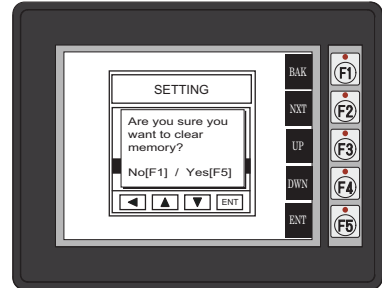

The Factory Default values are:

- LCD Contrast value of 8
- Green backlight color for EA1-S6ML, white backlight color for EA1-S6MLW
- The internal audible beeper enabled
- Forced touch panel calibration
- User program cleared from memory
- Hourglass icon delay of 350 ms.
- Horizontal orientation



NOTE: User memory is cleared when factory defaults are reset. Use the C-more Micro-Graphic programming software to read the program from the panel and save a backup copy.

Setting – Hourglass

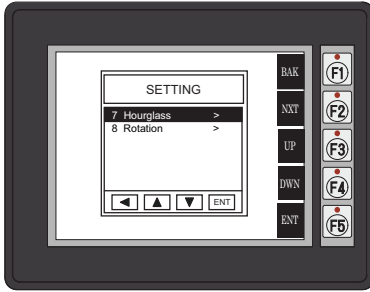

The **Hourglass** selection listed under the **Setting** menu can be used to either disable the display of the hourglass icon or set the amount of delay time (0 ms to 1000 ms) desired before it is displayed.

With **Hourglass** highlighted, press ENT [F5]. The UP [F3] and DWN [F4] function keys scroll through the selections. Use the APL [F5] function key to apply the selection.

Explanation: An hourglass icon is displayed on the panel anytime a new screen is being loaded until communication is established with the new screen. If communication is established before the delay has timed out, no hourglass will be displayed. The hourglass icon can also be disabled from being displayed.

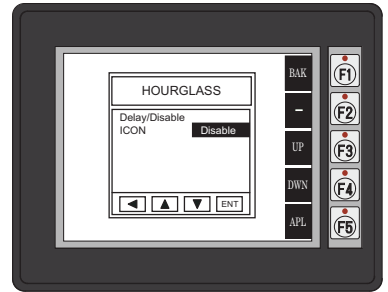
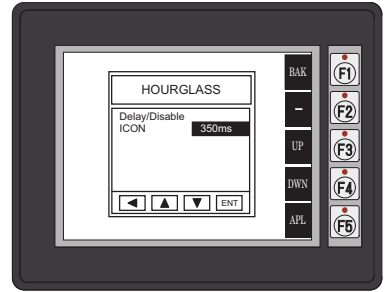

Hourglass Icon

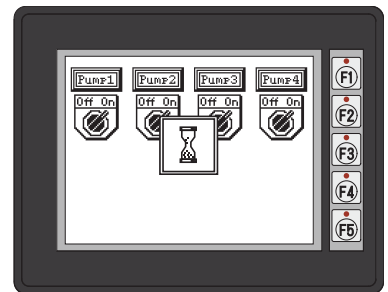

Setting – Rotation

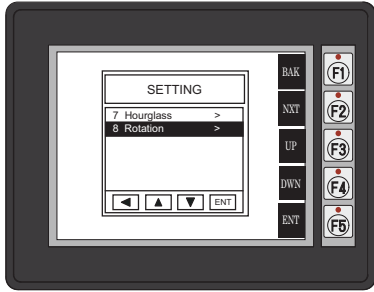

With **Rotation** highlighted, press ENT [F5] to show the current orientation. Press UP [F3] and DWN [F4] to toggle between the portrait (vertical) and landscape (horizontal) orientation. Use the APL [F5] function button to apply the selection.

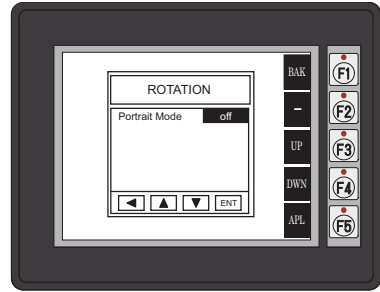

5



Note: Loading a project to the panel will override the orientation chosen from the System Setup Screens' Rotation selection screen. The selected orientation is displayed only when in the System Setup Screens.

Test Menu

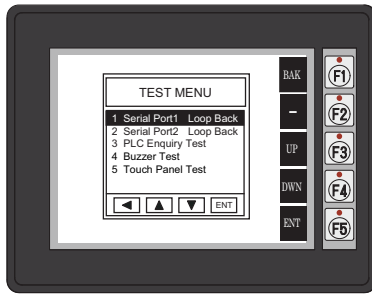

Use the UP [F3] and DWN [F4] function keys to scroll through the list of tests. The BAK [F1] function key will return you to the previous screen. Use the ENT [F5] function key to make your selection once you have the test highlighted.

The Test Menu screen includes the following:

Serial Port1 - Loop Back Test – page 5-15

Serial Port2 - Loop Back Test – page 5-16

PLC Enquiry Test – page 5-17

Buzzer Test – page 5-17

Touch Panel Test – page 5-18

5

Test Menu – Serial Port1 - Loop Back Test

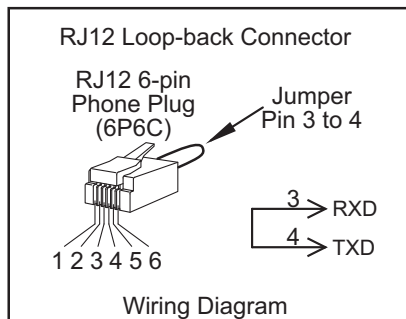
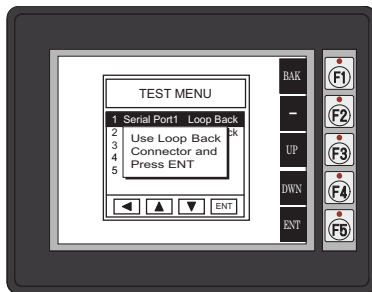

With Serial Port1 - Loop Back Test highlighted, press ENT [F5] to bring up the screen shown to the left. Connect a loop back connector constructed as shown here and press ENT [F5] to start the test. If the test is passing, the **Receive Counts** will equal the **Bytes Sent**. If the serial port is not working, then the **Error Counts** will equal the **Bytes Sent**. The test will continue until the BAK [F1] key is pressed.

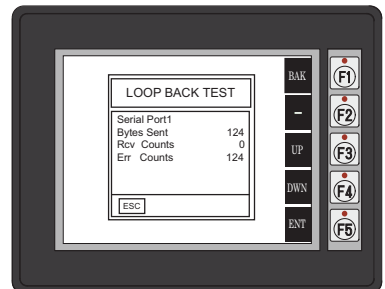
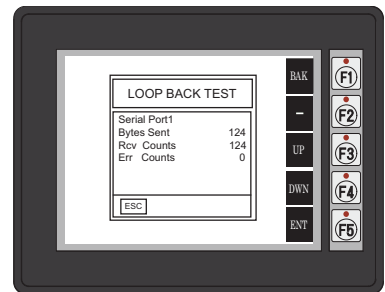

Test Menu – Serial Port2 - Loop Back Test

5

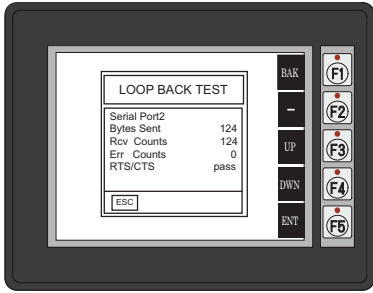

With Serial Port2 - Loop Back Test highlighted, press ENT [F5] to bring up the screen shown to the right. At this point, either connect the RS-232 loop back connector or the RS-422/485 loop backconnector, depending on which type of communications connection is being used, and press ENT [F5] to start the test. If the test is passing, the **Receive Counts** will equal the **Bytes Sent**. If the serial port is not working, then the **Error Counts** will equal the **Bytes Sent**. The **RTS/CTS** signals will also show either **pass** or **fail** as shown to the right. The test will continue until the BAK [F1] key is pressed.

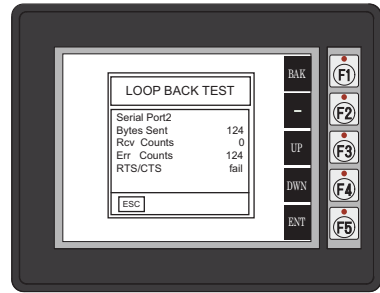
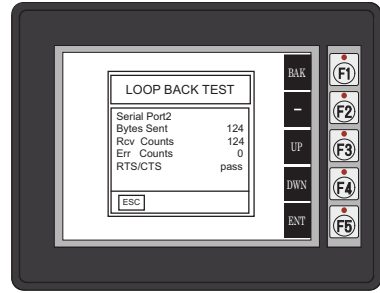
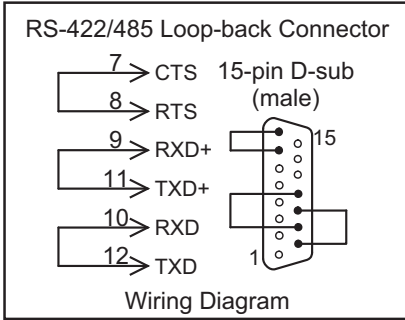
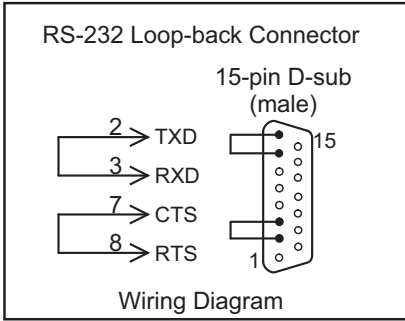
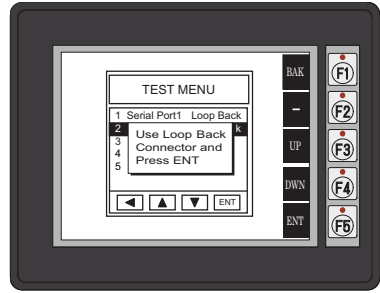

Test Menu – PLC Enquiry Test

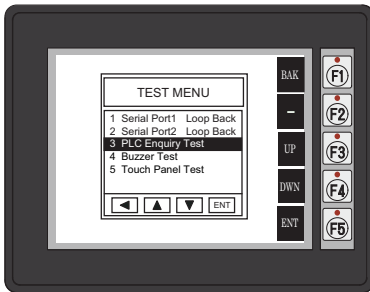

With **PLC Enquiry Test** highlighted, press ENT [F5] to bring up the screen shown to the right. If the PLC is connected to the panel, press ENT [F5] to start the test. Four data tests will be performed and indicated as either **Test Passed** or **Test Failed** as shown on this page. The BAK [F1] key can be pressed to cancel the test and/or returned to the previous screen.

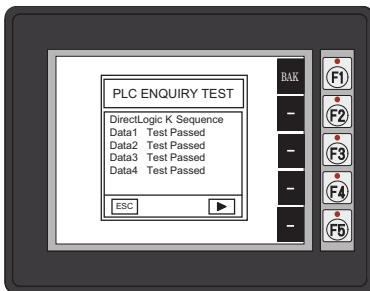
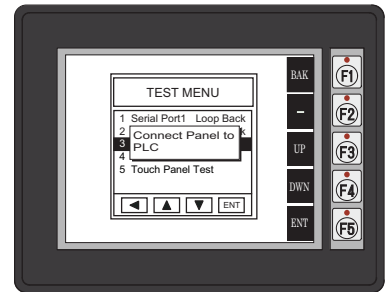

Test Menu – Buzzer Test

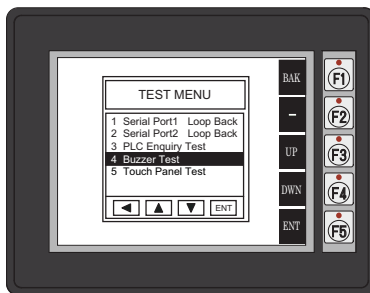

With **Buzzer Test** selection highlighted, press ENT [F5] to run the test on the internal audible beeper. The beeper will sequence up the scale through eight notes and then start over. The BAK [F1] key can be pressed to cancel the test.



Note: The beeper tone is not selectable. The beeper function can not be turned on or off from this screen, refer to the Setting menu.



Note: When the panel is powered through Port1 from a connected PLC or PC, the beep will not function properly because the panel is running in **Low-Power Mode**. To use the beep signal, power the panel from an external 12-24 VDC power source.

Test Menu - Touch Panel Test

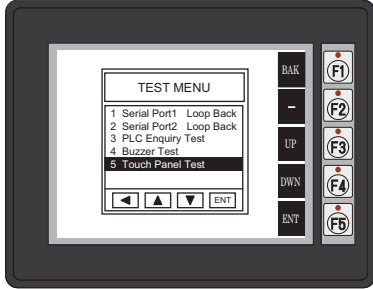

With **Touch Panel Test** highlighted, press ENT [F5] to bring up the screen shown to the right. Touch any area of the screen to visualize the active area of the touch screen. If the touch panel area is working properly, the screen will blacken at the area touched. Use this test to identify any area that is not responding properly. Press any key [F1 to F5] to return to the Test Menu.



Exit

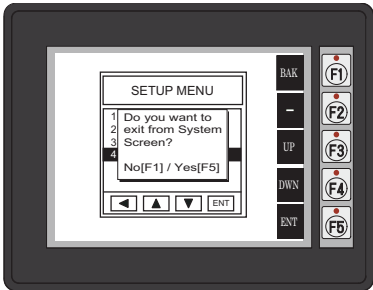

With **Exit** highlighted, press ENT [F5] to bring up the screen shown to the left. You will be given the choice to either proceed with exiting the **System Setup Screens** by pressing [F5] for YES or allowed to cancel by pressing [F1] for NO. You will be returned to the project screen if answering YES.

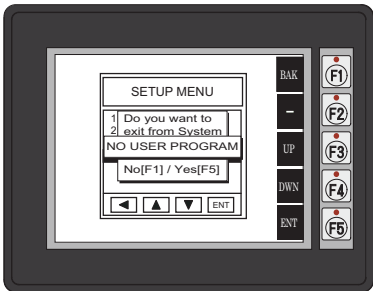

If there is no user program loaded into the panel, then a **NO USER PROGRAM** message as shown to the left will be displayed.

PLC COMMUNICATIONS



In This Chapter...

Introduction	6-2
Available PLC Protocols	6-3
C-more 6" Micro-Graphic Communication Ports	6-4
DirectLOGIC PLCs Password Protection	6-6
PLC Compatibility and Connection Charts	6-6
AutomationDirect CLICK PLC:	6-6
Direct LOGIC PLCs RS-422A/RS-485A:	6-7
Allen-Bradley:	6-7
GE, Mitsubishi, Omron, Modicon and Siemens:	6-7
How to use the PLC Compatibility and Connection Charts	6-8
Example:	6-8
Cables from AutomationDirect	6-15
Cables from AutomationDirect – Wiring Diagrams	6-17
User Constructed Cables – Wiring Diagrams	6-26
RS-422A/RS-485A Multi-Drop Wiring Diagram Examples	6-32

Introduction

The *C-more*[®] 6" Micro-Graphic panels are capable of communicating with AutomationDirect CLICK and the entire *Direct*LOGIC family of PLCs. The panel is capable of communicating using RS232 on Port1 and RS232, RS422 or RS485 on Port2. When using Port1, a RJ12 serial port, the *C-more* 6" Micro-Graphic panel connects with the CLICK, DL05, DL06, DL105, DL205, D3-350 and DL405 CPUs using the following cables.

- DV-1000CBL – connects to CLICK, DL05, DL06, DL105, DL205, D3-350 and D4-450 phone jack: RJ12 - RJ12
- D4-1000CBL – connects to all DL405 CPU 15-pin ports. : RJ12 - 15-pin D-sub

The *C-more*[®] 6" Micro-Graphic panel can also communicate using RS232, RS422 or RS485 using the following cables.

- EA-2CBL - connects to CLICK, DL05, DL105, DL205, DL350, DL450, H2-WINPLC phone jack: RJ12 - 15 pin D-sub.
- EA-2CBL-1 - connects to D2-250, D250-1, D2-260, DL06 VGA connector: 15-pin HD - 15 pin D-sub.

The panel also has the ability to communicate with Allen-Bradley PLCs that support the Allen-Bradley DF1 and DH485 protocols. Use Port2 with the following cables to connect the panel to a majority of Allen-Bradley PLCs.

- EA-MLOGIX-CBL – connects to AB MicroLogix 1000, 1100, 1200 & 1500: 15-pin D-sub - 8-pin DIN
- EA-SLC-232-CBL – connects to AB SLC 5/03, /04, /05, ControlLogix, CompactLogix, FlexLogix: 15-pin D-sub - 9-pin Dshell female
- EA-PLC5-232-CBL – connects to AB PLC5: 15-pin Dshell - 25-pin Dshell
- EA-DH485-CBL – connects to AB MicroLogix, SLC500, and any PLC using AB AIC device: 15-pin Dshell - RJ45 8-pin

The PLC Compatibility and Connection Chart tables on the following pages list all of the various PLCs and protocols that can be configured. Other third party PLCs include GE, Mitsubishi, Omron, Modicon and Siemens. The rest of this chapter shows the pin to pin connections of all the available cables plus wiring diagrams to construct cables.



NOTE: Refer to the PLC Compatibility and Connection Charts beginning on page 6-8 for a complete listing of PLC connections for the *C-more* 6" Micro-Graphic panel.



NOTE: A maximum cable length of 10 feet between the *C-more* Micro-Graphic panel and the PLC is recommended when powering the panel from the PLC.



NOTE: When the panel is powered through Port1 from a connected PLC or PC, the screen brightness is diminished because the panel is running in **Low-Power Mode**. For full brightness, connect an external 12-24 VDC power source to the panel's power connection. **Low-Power Mode** is intended for initial programming. For full brightness, connect an external 12-24 VDC power source when the panel is installed in its application.

Introduction (cont'd)

Available PLC Protocols

PLC Drivers	
<i>Serial - port1 or port2</i>	<i>Serial - port2 only</i>
AutomationDirect CLICK	Allen-Bradley DF1 Half Duplex
AutomationDirect K-sequence	Allen-Bradley DF1 Full Duplex
AutomationDirect DirectNET	Allen-Bradley PLC5 DF1
AutomationDirect Modbus	Allen-Bradley DH485
Modicon Modbus RTU	GE SNPX (90/30, 90/70, Micro 90, VersaMax Micro)
Entivity Modbus RTU	Mitsubishi FX
	Mitsubishi Q & QnA
	Omron Host Link (C200 Adapter, C500)
	Omron FINS Serial (CJ1, CS1)
	Siemens PPI (S7-200 CPU)

The panel can also be connected to more than one PLC by using RS-422 or RS-485 wired in a multi-drop configuration. Port1 and Port2 cannot simultaneously communicate with multiple PLC's. See the example wiring diagrams at the end of this chapter for details.

If you have difficulty determining whether the particular PLC and/or protocol you are using will work with *C-more* Micro-Graphic panels, please contact our technical support group at 770-844-4200.

C-more 6" Micro-Graphic Communication Ports

Example of panel's Port1 connected to a CLICK PLC

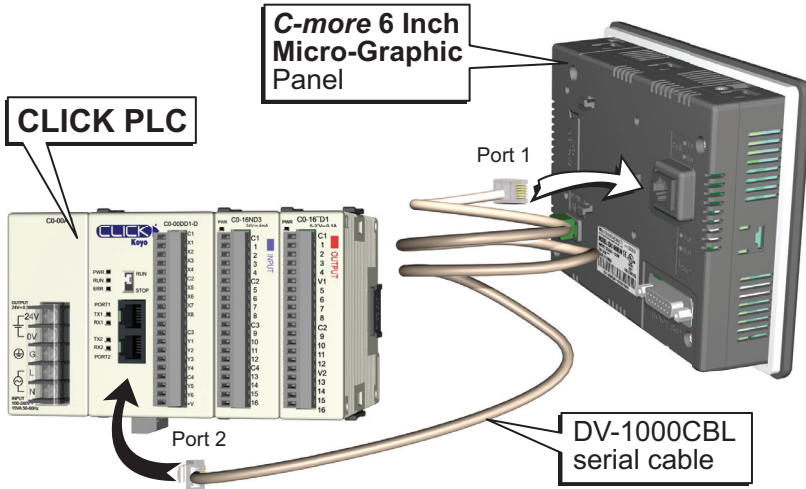

Example of panel's Port2 connected to a DL06 PLC

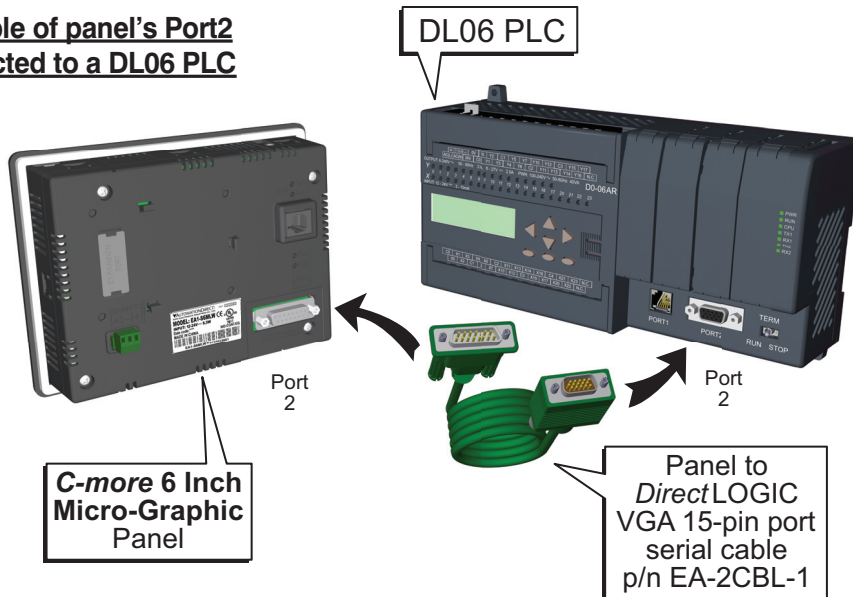

6

C-more 6" Micro-Graphic Communication Ports (cont'd)

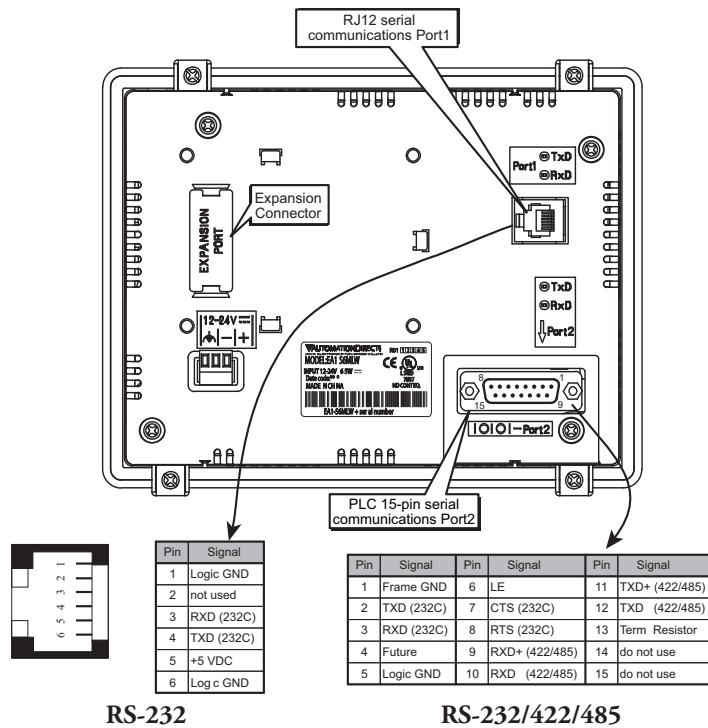

NOTE: Only one of the communication ports can be used with a connected PLC. The programming software allows the user to select either Port1 or Port2 under the Panel Manager dialog box. When using Port2 to communicate with the connected PLC, Port1 can still be used with the EA-MG-PGM-CBL Software Programming Cable Assembly to transfer projects between the PC and panel.

DirectLOGIC PLCs Password Protection



NOTE: *DirectLOGIC PLCs support multi-level password protection of the ladder program. This allows password protection while not locking the communication port to an operator interface. The multilevel password can be invoked by creating a password with an upper case "A" followed by any variation of seven numeric characters (e.g. A1234567). Please refer to the specific PLC user manual for further details.*

PLC Compatibility and Connection Charts

The following pages include charts that list the possible connections available between several brands of PLC's and the *C-more* 6" Micro-Graphic panel. AutomationDirect PLC's have the ability to communicate and provide power to the panel using Port1 (RS-232). Port2 is a 15-pin D-sub communication port that supports RS-232, RS-485 and RS-422. An external 1 Amp @ 12-24 VDC external power source is required when using Port2.



Note: *Recommended DC power supply to power the **C-more** Micro-Graphic Panel, **AutomationDirect** Part No. PSP24-024S or PSP24-024C.*

The charts include the various PLC protocols that can be used with each combination of PLC port and panel port.

The charts list the recommended cables and/or manufactured devices that can be used to make up the communications link, and also refers to wiring diagrams that can be used to construct cables for connecting the PLC's port to the panel's port. The constructed cables are referred to as Diagram 1 through 13 and start on page 6-26.

Following the charts is a list of cables that can be purchased, including their wiring diagrams, and also wiring diagrams that are referenced from the charts that can be used to construct the referenced cables.

AutomationDirect CLICK PLC:

AutomationDirect's practically free PLC, CLICK, can be used with RS-232 2-wire networks. *C-more* Micro-Graphic panels are an ideal partner for CLICK which:

- Is low cost
- Is easy to use
- Uses standard Modbus communication
- Is programmed by free CLICK programming software
- Has com ports that provide 5 VDC
- The maximum communication speed between a CLICK PLC and a *C-more* Micro-Graphic panel is 38.4 Kbps.



Note: *Only one **C-more** Micro-Graphic panel can be powered by an AutomationDirect PLC. If connecting **C-more** Micro-Graphic panels to more than one port on and AutomationDirect PLC, the additional panel must use an external power supply.*

PLC Compatibility and Connection Charts (cont'd)

***Direct* LOGIC PLCs RS-422A/RS-485A:**

When using the RS-422A/RS-485A communications capabilities of the *C-more* Micro-Graphic Serial Port (Port 2), the termination resistor is placed between the **RXD-** and **RXD+** terminals on the PLC side of the connection between the touch panel and PLC. The Termination Resistor value is based on the characteristic impedance of the cable being used. To enable the built-in 120 Ohm Termination Resistor, jumper pin **13** (termination resistor) to pin **9** (**RXD+**) on the C-more 15-pin PLC communications port.

Allen-Bradley:

As stated in this chapter's introduction, the panel also has the ability to communicate with Allen-Bradley PLCs that support the Allen-Bradley DF1 and DH485 protocols. The chart for the various Allen-Bradley PLCs includes recommended cables.

GE, Mitsubishi, Omron, Modicon and Siemens:

Other 3rd party PLCs can be used with the *C-more* Micro-Graphic panel. These PLCs are listed in a chart and various wiring diagrams are shown to allow connectivity.

How to use the PLC Compatibility and Connection Charts

- 1.) Find the PLC Family being used.
- 2.) Find the particular PLC model in the PLC family.
- 3.) Find the PLC communications port you will be connecting to the *C-more* Micro-Graphic panel.
- 4.) Read across the chart to determine if the *C-more* Micro-Graphic panel's Port1 and / or Port2 can be used and then determine the cable and other components, manufactured or user constructed, are required.

Example:

6

PLC Compatibility & Connection Chart									
PLC			<i>C-more</i> Micro-Graphic Panel						
Family	CPU	PLC Port & Type	Panel to PLC Cabling Components Required for Specific Port and Protocol being used.				External DC Power Supply		
			**PLC Port Powered or External DC Power Supply			Using panel's Port2 DB 15-pin - female			
			Using panel's RJ12 Port1			Protocol(s) Supported	Components & Network Type	Protocol(s) Supported	Components & Network Type
			Protocol(s) Supported	Components & Network Type		Protocol(s) Supported	Components & Network Type		
CLICK	all versions	Port 1 RJ12 - 6 pin	AutomationDirect Modbus (CLICK)	DV-1000CBL* RS-232	AutomationDirect Modbus (CLICK)	EA-2CBL RS-232			
		Port 2 RJ12 - 6 pin	K-sequence, <i>DirectNET</i> , Modbus RTU	DV-1000CBL* RS-232	K-sequence, <i>DirectNET</i> , Modbus RTU	EA-2CBL RS-232			
DirectLOGIC DL05	all versions	Port 1 RJ12 - 6 pin	K-sequence, <i>DirectNET</i> , Modbus RTU	DV-1000CBL* RS-232	K-sequence, <i>DirectNET</i> , Modbus RTU	EA-2CBL RS-232			
		Port 2 RJ12 - 6 pin		DV-1000CBL* RS-232		EA-2CBL-1 RS-232			
	D0-DCM	Port 2 DB15HD (female)	K-sequence, <i>DirectNET</i> , Modbus RTU	DV-1000CBL* + FA-15HD RS-232	Modbus RTU	** See Diagram 1 RS-422			
						** See Diagram 2 RS-485 Modbus only			

**AutomationDirect CLICK PLC,
DirectLOGIC DL05, DL06, D0-DCM Module & DL105 PLCs
Panel Powered via external power supply, Port1 or Port2 Communications**

PLC Compatibility & Connection Chart								
PLC			C-more Micro-Graphic Panel					
Family	CPU	PLC Port & Type	Panel to PLC Cabling Components Required for Specific Port and Protocol being used.					
			*PLC Port Powered or External DC Power Supply		External DC Power Supply			
			Using panel's RJ12 Port1		Using panel's Port2 DB 15-pin - female			
			Protocol(s) Supported	Components & Network Type	Protocol(s) Supported	Components & Network Type		
CLICK	all versions	Port 1 RJ12 - 6 pin	AutomationDirect Modbus (CLICK)	DV-1000CBL* RS-232	AutomationDirect Modbus (CLICK)	EA-2CBL RS-232		
DirectLOGIC DL05	all versions	Port 1 RJ12 - 6 pin	K-sequence, DirectNET , Modbus RTU	DV-1000CBL* RS-232	K-sequence, DirectNET , Modbus RTU	EA-2CBL RS-232		
		Port 2 RJ12 - 6 pin						
	D0-DCM	Port 1 RJ12 - 6 pin	K-sequence, DirectNET , Modbus RTU	DV-1000CBL* RS-232	K-sequence, DirectNET , Modbus RTU	EA-2CBL RS-232		
		Port 2 DB15HD (female)					DV-1000CBL* + FA-15HD RS-232	** See Diagram 1 RS-422
Direct LOGICDL06	all versions	Port 1 RJ12 - 6 pin	K-sequence, DirectNET , Modbus RTU	DV-1000CBL* RS-232	K-sequence, DirectNET , Modbus RTU	EA-2CBL RS-232		
		Port 2 DB15HD (female)					DV-1000CBL* + FA-15HD RS-232	** See Diagram 1 RS-422
							Modbus RTU	** See Diagram 2 RS-485 Modbus only
	D0-DCM	Port 1 RJ12 - 6 pin	K-sequence, DirectNET , Modbus RTU	DV-1000CBL* RS-232	K-sequence, DirectNET , Modbus RTU	EA-2CBL RS-232		
		Port 2 DB15HD (female)					DV-1000CBL* + FA-15HD RS-232	** See Diagram 1 RS-422
							Modbus RTU	** See Diagram 2 RS-485 Modbus only
DirectLOGIC DL105	all versions	Port 1 RJ12 - 6 pin	K-sequence	DV-1000CBL* RS-232	K-sequence	EA-2CBL RS-232		

* Note: The PLC can provide 5 VDC through this cable. No external 12-24 VDC source is required, however, screen brightness is diminished and the alarm beep will not function.

** Note: Wiring Diagrams for user constructed cables start on page 6-26.

**DirectLOGIC DL205 PLCs, D2-DCM Module and WINPLC
Panel Powered via external power supply, Port1 or Port2 Communications**

6

PLC Compatibility & Connection Chart						
PLC			C-more Micro-Graphic Panel			
Family	CPU	PLC Port & Type	Panel to PLC Cabling Components Required for Specific Port and Protocol being used.			
			*PLC Port Powered or External DC Power Supply		External DC Power Supply	
			Using panel's RJ12 Port1		Using panel's Port2 DB 15-pin - female	
			Protocol(s) Supported	Components & Network Type	Protocol(s) Supported	Components & Network Type
DirectLOGIC DL205	D2-230	Port 1 RJ12 - 6 pin	K-sequence	DV-1000CBL* RS-232	K-sequence	EA-2CBL RS-232
	D2-240	Port 1 RJ12 - 6 pin	K-sequence	DV-1000CBL* RS-232	K-sequence	EA-2CBL RS-232
		Port 2 RJ12 - 6 pin	K-sequence, <i>DirectNET</i>		K-sequence, <i>DirectNET</i>	
	D2-250-1	Port 1 RJ12 - 6 pin	K-sequence, <i>DirectNET</i> , Modbus RTU	DV-1000CBL* RS-232	K-sequence, <i>DirectNET</i> , Modbus RTU	EA-2CBL RS-232
		Port 2 DB15HD (female)		DV-1000CBL* + FA-15HD RS-232		EA-2CBL-1 RS-232 ** See Diagram 1 RS-422
	D2-260	Port 1 RJ12 - 6 pin	K-sequence, <i>DirectNET</i> , Modbus RTU	DV-1000CBL* RS-232	K-sequence, <i>DirectNET</i> , Modbus RTU	EA-2CBL RS-232
		Port 2 DB15HD (female)		DV-1000CBL* + FA-15HD RS-232		EA-2CBL-1 RS-232 ** See Diagram 1 RS-422
					Modbus RTU	** See Diagram 2 RS-485 Modbus only
	D2-DCM	Port 1 DB 25 pin (female)	K-sequence, <i>DirectNET</i> , Modbus RTU	** See Diagram 3 RS-232	<i>DirectNET</i>	EA-4CBL-2 RS-232 ** See Diagram 6 RS-422
	WINPLC	Port 1 RJ12 - 6 pin	Modbus RTU	DV-1000CBL* RS-232	Modbus RTU	EA-2CBL RS-232

* Note: The PLC can provide 5 VDC through this cable. No external 12-24 VDC source is required, however, screen brightness is diminished and the alarm beep will not function.
 ** Note: Wiring Diagrams for user constructed cables start on page 6-26.

DirectLOGIC DL305 PLCs and D3-DCM Module

Panel Powered via external power supply, Port1 or Port2 Communications

PLC Compatibility & Connection Chart						
PLC			C-more Micro-Graphic Panel			
Family	CPU	PLC Port & Type	Panel to PLC Cabling Components Required for Specific Port and Protocol being used.			
			* PLC Port Powered or External DC Power Supply		External DC Power Supply	
			Using panel's RJ12 Port1		Using panel's Port2 DB 15-pin - female	
			Protocol(s) Supported	Components & Network Type	Protocol(s) Supported	Components & Network Type
DirectLOGIC DL305	D3-330 or D3-340	D3-232-DCU DB 25 pin (female)	<i>Direct</i> NET	EA-4CBL-2 RS-232	<i>Direct</i> NET	EA-4CBL-2 RS-232
		D3-422-DCU DB 25 pin (female)	Not Possible		<i>Direct</i> NET	** See Diagram 6 RS-422
	D3-340	Port 1 RJ11 - 4 pin	<i>Direct</i> NET	OP-3CBL-1 RS-232	<i>Direct</i> NET	EA-3CBL RS-232
		Port 2 RJ11 - 4 pin	<i>Direct</i> NET, Modbus RTU		<i>Direct</i> NET, Modbus RTU	
	D3-350	Port 1 RJ12 - 6 pin	K-sequence, <i>Direct</i> NET	DV-1000CBL* RS-232	K-sequence, <i>Direct</i> NET	EA-2CBL RS-232
		Port 2 DB 25 pin (female)	K-sequence, <i>Direct</i> NET, Modbus RTU	** See Diagram 3 RS-232	K-sequence, <i>Direct</i> NET, Modbus RTU	EA-4CBL-2 RS-232 ** See Diagram 4 RS-422
	D3-DCM D3-350 only	Port 1 DB 25 pin (female)	K-sequence, <i>Direct</i> NET, Modbus RTU	** See Diagram 3 RS-232	<i>Direct</i> NET	EA-4CBL-2 RS-232 ** See Diagram 6 RS-422

* Note: The PLC can provide 5 VDC through this cable. No external 12-24 VDC source is required, however, screen brightness is diminished and the alarm beep will not function.

** Note: Wiring Diagrams for user constructed cables start on page 6-26.

DirectLOGIC DL405 PLCs and D4-DCM Module

Panel Powered via external power supply, Port1 or Port2 Communications

6

PLC Compatibility & Connection Chart						
PLC			C-more Micro-Graphic Panel			
Family	CPU	PLC Port & Type	Panel to PLC Cabling Components Required for Specific Port and Protocol being used.			
			*PLC Port Powered or External DC Power Supply		External DC Power Supply	
			Using panel's RJ12 Port1		Using panel's Port2 DB 15-pin - female	
			Protocol(s) Supported	Components & Network Type	Protocol(s) Supported	Components & Network Type
DirectLOGIC DL405	D4-430	Port 0 DB 15 pin (female)	K-sequence	D4-1000CBL or DV-1000CBL* & FA-CABKIT RS-232	K-sequence	EA-4CBL-1 RS-232
		Port 1 DB 25 pin (female)	K-sequence, DirectNET	DV-1000CBL* & FA-CABKIT RS-232	K-sequence, DirectNET	EA-4CBL-2 RS-232 ** See Diagram 4 RS-422
	D4-440	Port 0 DB 15 pin (female)	K-sequence	D4-1000CBL or DV-1000CBL* & FA-CABKIT RS-232	K-sequence	EA-4CBL-1 RS-232
		Port 1 DB 25 pin (female)	K-sequence, DirectNET	DV-1000CBL* & FA-CABKIT RS-232	K-sequence, DirectNET	EA-4CBL-2 RS-232 ** See Diagram 4 RS-422
	D4-450	Port 0 DB 15 pin (female)	K-sequence	D4-1000CBL or DV-1000CBL* & FA-CABKIT RS-232	K-sequence	EA-4CBL-1 RS-232
		Port 1 DB 25 pin (female)	K-sequence, DirectNET , Modbus RTU	DV-1000CBL* & FA-CABKIT RS-232	K-sequence, DirectNET , Modbus RTU	EA-4CBL-2 RS-232 ** See Diagram 4 RS-422
		Port 3 DB 25 pin (female)	Not Possible		K-sequence, DirectNET , Modbus RTU	** See Diagram 5 RS-422
		Port 2 RJ12 - 6 pin	K-sequence, DirectNET	DV-1000CBL* RS-232	K-sequence, DirectNET	EA-2CBL RS-232
	D4-DCM	Port 1 DB 25 pin (female)	K-sequence, DirectNET , Modbus RTU	** See Diagram 3 RS-232	DirectNET	EA-4CBL-2 RS-232 ** See Diagram 6 RS-422

* Note: The PLC can provide 5 VDC through this cable. No external 12-24 VDC source is required, however, screen brightness is diminished and the alarm beep will not function.
 ** Note: Wiring Diagrams for user constructed cables start on page 6-26.

Allen-Bradley PLCs

Panel Powered via external power supply, Port1 or Port2 Communications

PLC Compatibility & Connection Chart						
PLC			<i>C-more</i> Micro-Graphic Panel			
Family	CPU	PLC Port & Type	Panel to PLC Cabling Components Required for Specific Port and Protocol being used.			
			External DC Power Supply			
			Powered from an external 24 VDC source			
			Using panel's RJ12 Port1		Using panel's Port2 DB 15-pin - female	
			Protocol(s) Supported	Components & Network Type	Protocol(s) Supported	Components & Network Type
Allen-Bradley MicroLogix	1000, 1100, 1200, 1500	8-pin mini-din port	Not Possible	DF1 Full Duplex, DF1 Half Duplex	EA-MLOGIX-CBL RS-232	
		RJ45 8-pin phone plug		DH485/AIC/AIC+	EA-DH485-CBL RS-232	
Allen-Bradley SLC500	5/03, 5/04, 5/05 5/01, 5/02, 5/03	9-pin D-sub port		DF1 Full Duplex, DF1 Half Duplex	EA-SLC-232-CBL RS-232	
		RJ45 8-pin phone plug		DH485/AIC/AIC+	EA-DH485-CBL RS-232	
Allen-Bradley ControlLogix	all	9-pin D-sub port		DF1 Full Duplex, DF1 Half Duplex	EA-SLC-232-CBL RS-232	
Allen-Bradley CompactLogix	all	9-pin D-sub port		DF1 Full Duplex, DF1 Half Duplex	EA-SLC-232-CBL RS-232	
Allen-Bradley FlexLogix	all	9-pin D-sub port		DF1 Full Duplex, DF1 Half Duplex	EA-SLC-232-CBL RS-232	
Allen-Bradley PLC5	all	25-pin D-sub port		DF1 Full Duplex	EA-PLC5-232-CBL RS-232	
		RJ45 8-pin phone plug		DH485/AIC/AIC+	EA-DH485-CBL RS-232	

**GE, Mitsubishi, Omron, Modicon and Siemens PLCs
Panel Powered via external power supply, Port1 or Port2 Communications**

6

PLC Compatibility & Connection Chart							
PLC			C-more Micro-Graphic Panel				
Family	CPU	PLC Port & Type	Panel to PLC Cabling Components Required for Specific Port and Protocol being used.				
			External DC Power Supply Powered from an external 24 VDC source.				
			Using panel's RJ12 Port1			Using panel's Port2 DB 15-pin - female	
			Protocol(s) Supported	Components & Network Type	Protocol(s) Supported	Components & Network Type	
GE	90/30, 90/70	15-pin D-sub port	Not Possible	SNPX	EA-90-30-CBL RS-422		
	Micro 90, VersaMax Micro	RJ45 Port 1			** See Diagram 12 RS-232		
		15-pin D-sub port Port 2			EA-90-30-CBL RS-422		
Mitsubishi	Melsec FX Series	25-pin D-sub port		CPU Direct	EA-MITSU-CBL RS-422		
		8-pin mini-din port			EA-MITSU-CBL-1 RS-422		
	Q / QnA	9-pin D-sub port		Q / QnA	** See Diagram 14 RS-232C		
		6-pin mini-din port			** See Diagram 15 RS-232C		
Omron	C200 (Adapter), C500	25-pin D-sub port		Host Link	EA-OMRON-CBL RS-232		
	CJ1, CS1, CQM1, CPM1, CPM2 C200 CPU	9-pin D-sub port		Host Link FINS	** See Diagram 7 & 8 RS-232		
Modicon	984 CPU, Quantum 113 CPU, AEG Modicon Micro Series 110 CPU	varies		Modbus RTU	** See Diagram 9, 10 & 11 RS-232		
Siemens	S7-200 CPU	9-pin D-sub port 0 or 1	PPI	** See Diagram 13 RS-485			

** Note: Wiring Diagrams for user constructed cables start on page 6-26.

Cables from AutomationDirect

Cable Description	Cable Part No.
Cables used with serial Port1	
AutomationDirect CLICK, <i>Direct</i> LOGIC PLC RJ-12 port, DL05, DL06, DL105, DL205, D3-350, D4-450 & H2-WinPLC (RS-232C)	DV-1000CBL
Note: The PLC can provide 5 VDC through this cable. No external 12-24 VDC source is required, however, screen brightness is diminished and the alarm beep will not function.	
<i>Direct</i> LOGIC DL405 PLC 15-pin D-sub port, DL405 (RS-232C)	D4-1000CBL
<i>Direct</i> LOGIC (VGA Style) 15-pin port, DL06, D2-250 (250-1), D2-260 (RS-232C) Use with DV-1000CBL cable.	FA-15HD
<i>Direct</i> LOGIC PLC 15-pin D-sub port, DL405 (RS-232C).	FA-CABKIT
<i>Direct</i> LOGIC PLC RJ-11 port, D3-340 (RS-232C).	OP-3CBL-1

Cable Description	Cable Part No.
Cables used with serial Port2	
AutomationDirect CLICK, <i>Direct</i> LOGIC PLC RJ-12 port, DL05, DL06, DL105, DL205, D3-350, D4-450 & H2-WinPLC (RS-232C)	EA-2CBL
<i>Direct</i> LOGIC (VGA Style) 15-pin port, DL06, D2-250 (250-1), D2-260 (RS-232C).	EA-2CBL-1
<i>Direct</i> LOGIC PLC RJ-11 port, D3-340 (RS-232C).	EA-3CBL
<i>Direct</i> LOGIC DL405 PLC 15-pin D-sub port, DL405 (RS-232C).	EA-4CBL-1
<i>Direct</i> LOGIC PLC 25-pin D-sub port, DL405, D3-350, DL305 DCU and all DCM's (RS-232C).	EA-4CBL-2
Allen-Bradley MicroLogix 1000, 1100, 1200 & 1500 (RS-232C)	EA-MLOGIX-CBL
Allen-Bradley SLC 5-03/04/05, ControlLogix, CompactLogix, FlexLogix DF1 port (RS-232C)	EA-SLC-232-CBL
Allen-Bradley PLC-5 DF1 port (RS-232C)	EA-PLC5-232-CBL
Allen-Bradley MicroLogix, SLC 5-01/02/03, PLC5 DH485 port (RS-232C)	EA-DH485-CBL
GE 90/30, 90/70, Micro 90, Versamax Micro (Port2) 15-pin D-sub port (RS-422A)	EA-90-30-CBL
mitsubishi FX Series 25-pin port (RS-422A)	EA-MITSU-CBL
mitsubishi FX Series 8-pin mini-DIN (RS-422A)	EA-MITSU-CBL-1
OMRON Host Link (C200 Adapter, C500) (RS-232C)	EA-OMRON-CBL



Part No. EA-2CBL



Part No. EA-2CBL-1



Part No. EA-3CBL



Part No. EA-4CBL-1



Part No. EA-4CBL-2

Cables from AutomationDirect (cont'd)



Part No. DV-1000CBL



Part No. OP-3CBL-1



Part No. FA-15HD



Part No. FA-CABKIT



Part No. D4-1000CBL



Part No. EA-MLOGIX-CBL



Part No. EA-SLC-232-CBL



Part No. EA-PLC5-232-CBL



Part No. EA-DH485-CBL



Part No. EA-90-30-CBL



Part No. EA-MITSU-CBL



Part No. EA-MITSU-CBL-1



Part No. EA-OMRON-CBL

Cables from AutomationDirect – Wiring Diagrams

The following series of wiring diagrams show the connectors and wiring details for the communication cables that are used between the *C-more* Micro-Graphic panels and various PLCs. Part numbers are included with the pre-made cables that can be purchased from *AutomationDirect*. The information presented will allow the user to construct their own cables if so desired.

CLICK & DirectLOGIC:

EA-2CBL

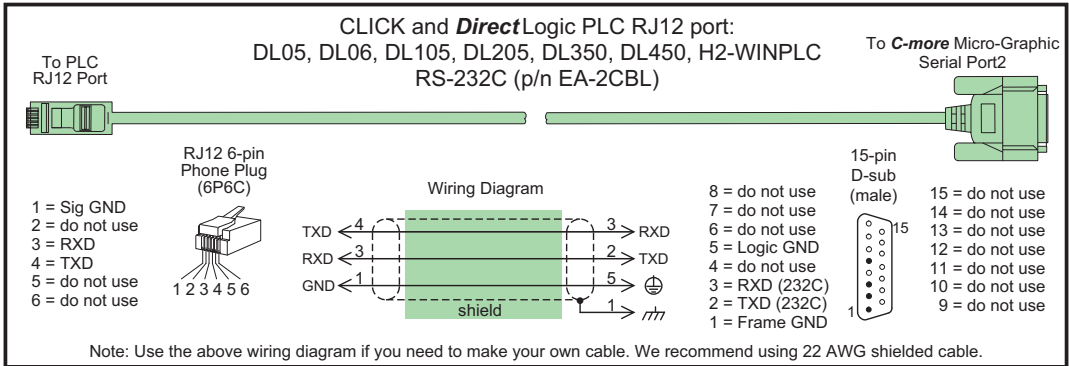

Note: Only one *C-more* Micro-Graphic panel can be powered by an *AutomationDirect* PLC. If connecting *C-more* Micro-Graphic panels to more than one port on an *AutomationDirect* PLC, the additional panel must use an external power supply.

DirectLOGIC:

EA-2CBL-1

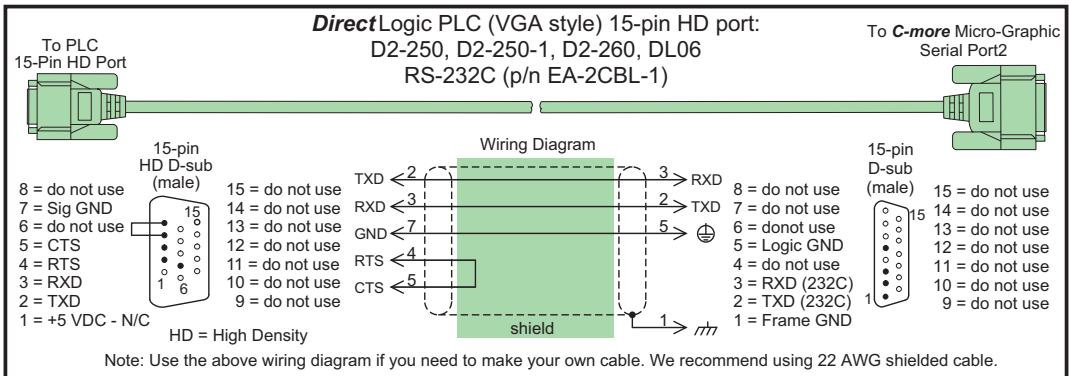

Cables from AutomationDirect – Wiring Diagrams (cont'd)

DirectLOGIC:

EA-3CBL

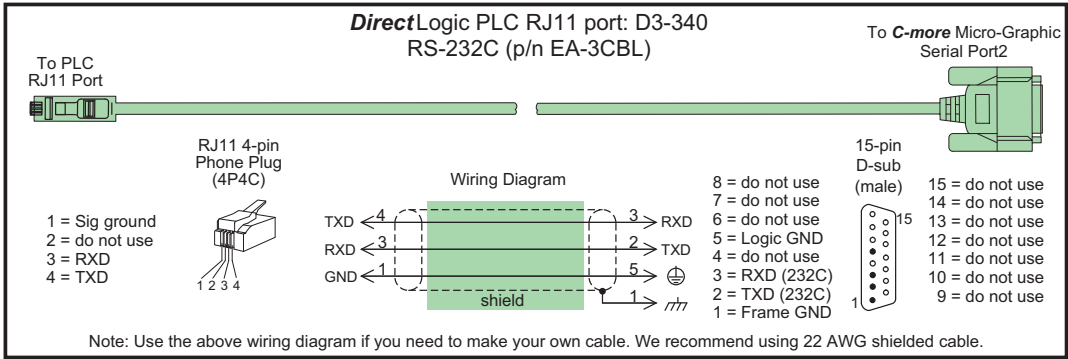

6

EA-4CBL-1

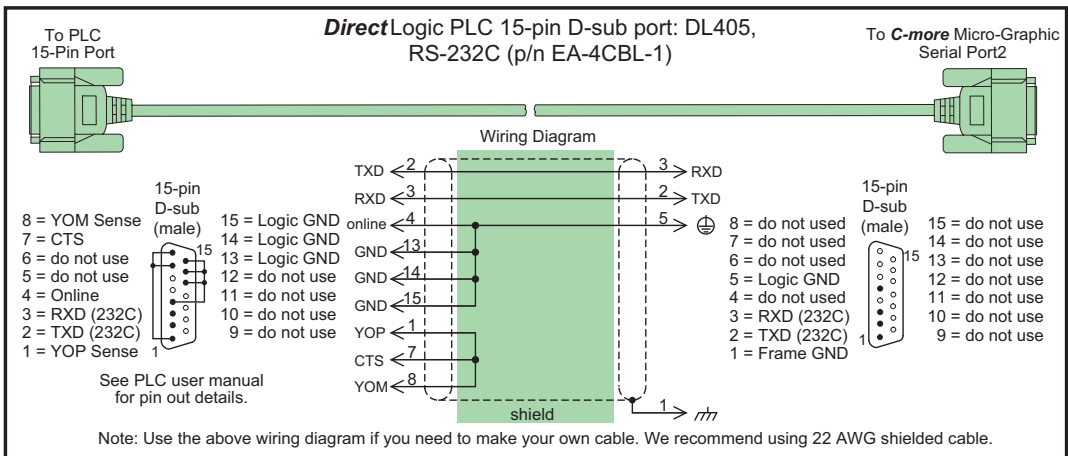

Cables from AutomationDirect – Wiring Diagrams (cont'd)

DirectLOGIC:

EA-4CBL-2

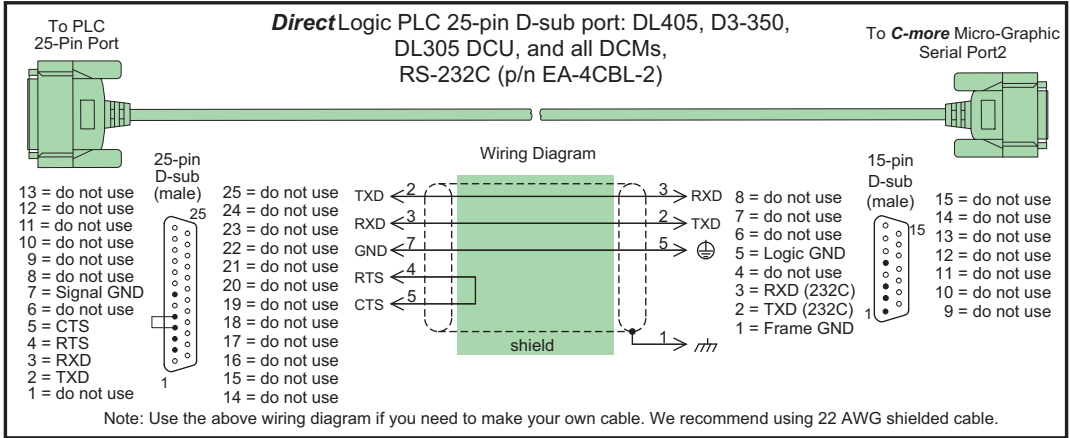

Cables from AutomationDirect – Wiring Diagrams (cont'd)

DV-1000CBL

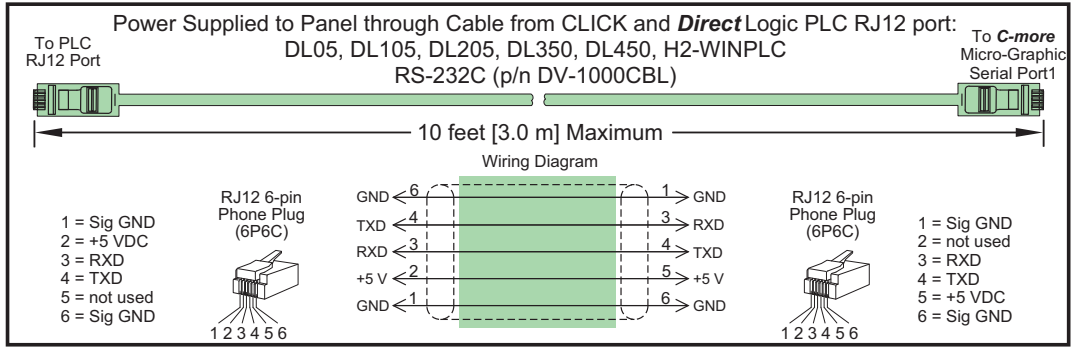

6



Note: Only one **C-more** Micro-Graphic panel can be powered by an AutomationDirect PLC. If connecting **C-more** Micro-Graphic panels to more than one port on an AutomationDirect PLC, the additional panel must use an external power supply.

OP-3CBL-1

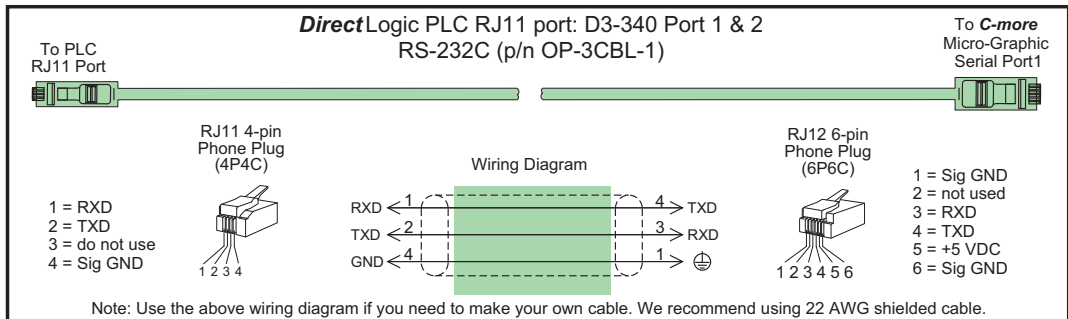

D4-1000CBL

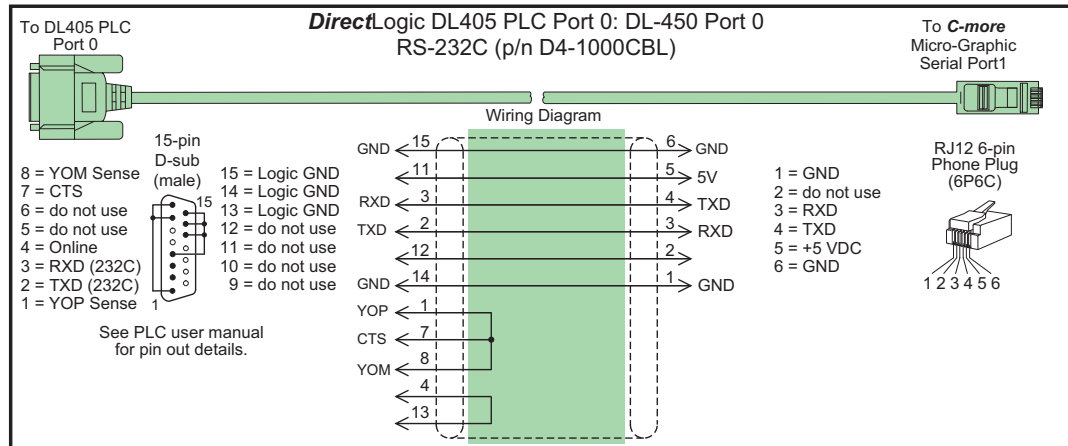

Cables from AutomationDirect - Wiring Diagrams (cont'd)

Allen-Bradley:

EA-MLOGIX-CBL

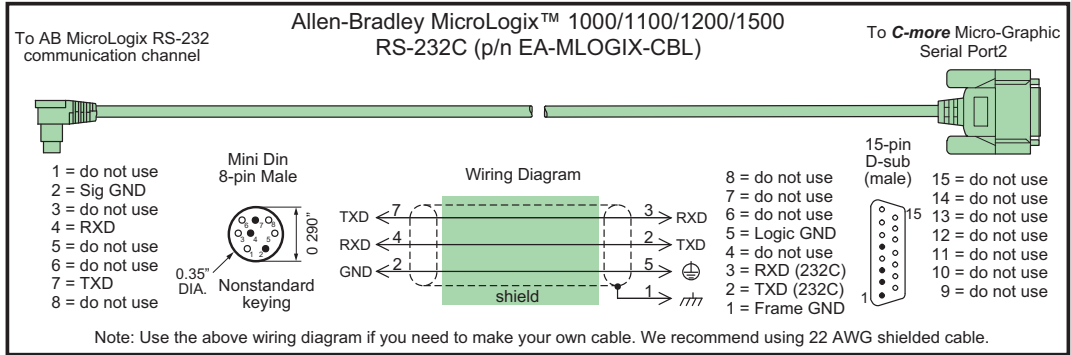

6

EA-SLC-232-CBL

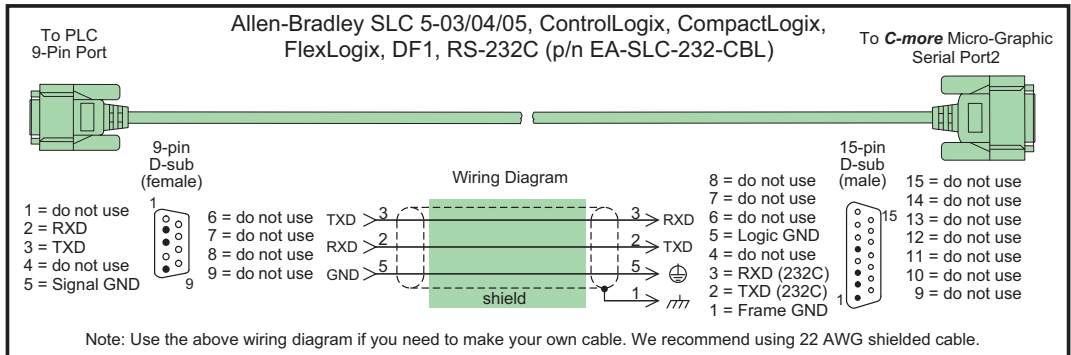

EA-PLC5-232-CBL

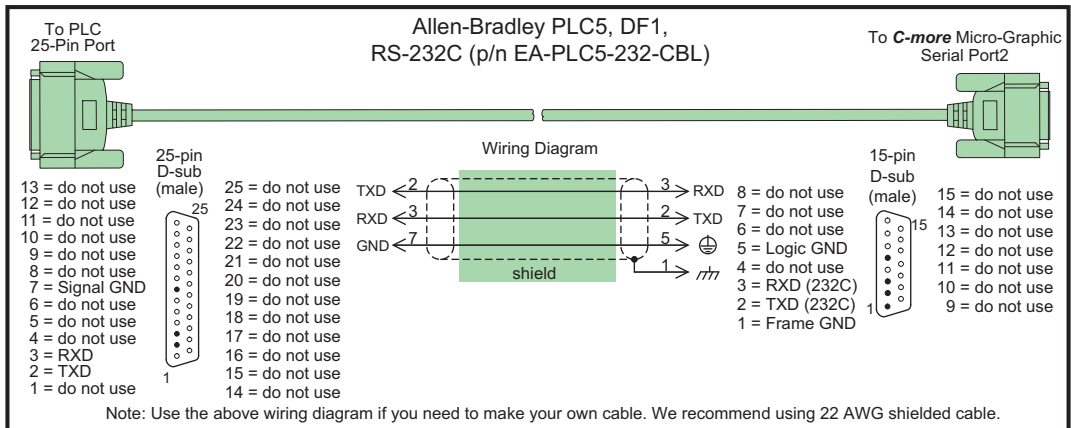

Cables from AutomationDirect - Wiring Diagrams (cont'd)

Allen-Bradley:

EA-DH485-CBL

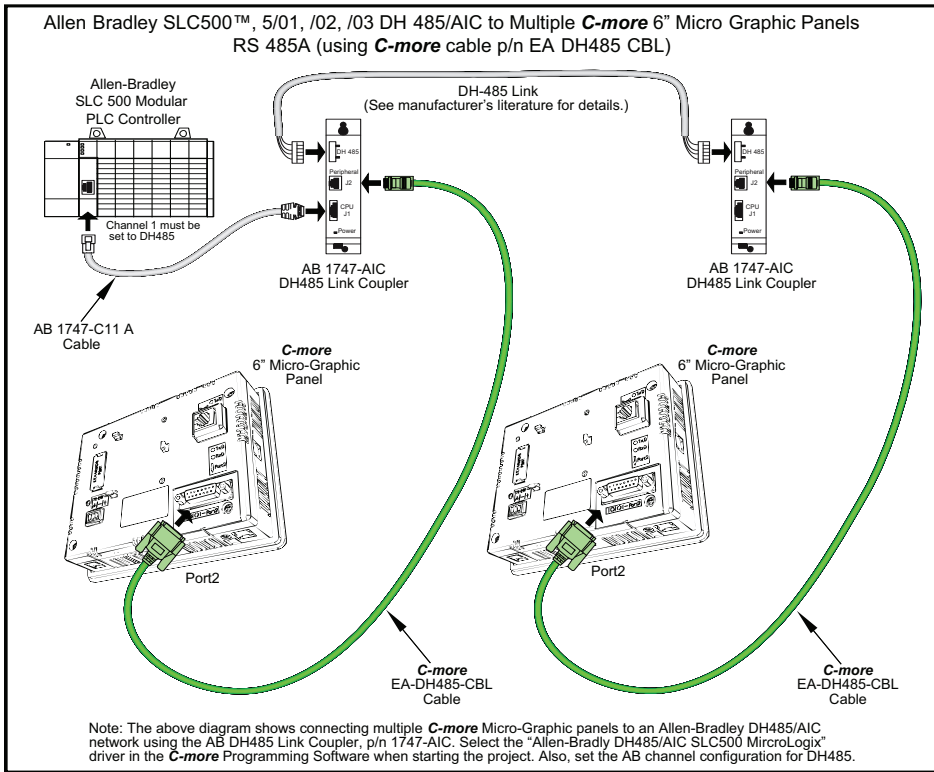
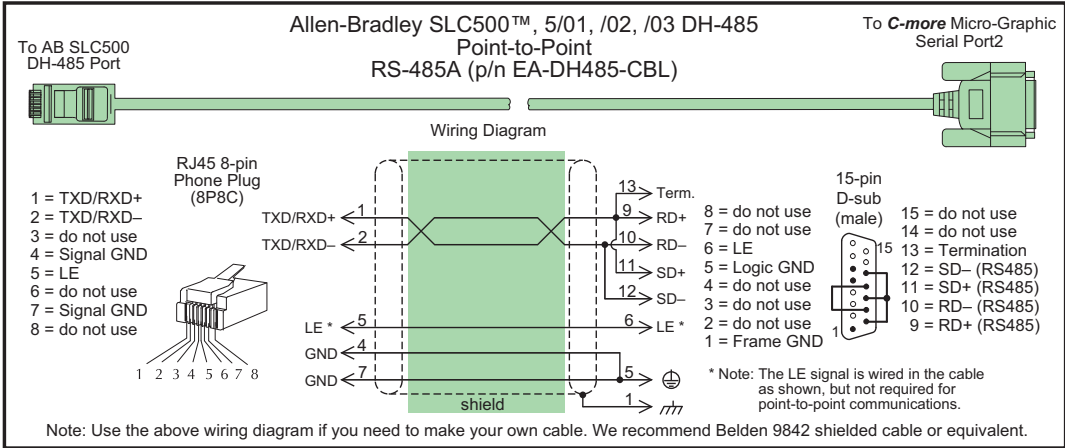

Cables from AutomationDirect - Wiring Diagrams (cont'd)

Allen-Bradley:

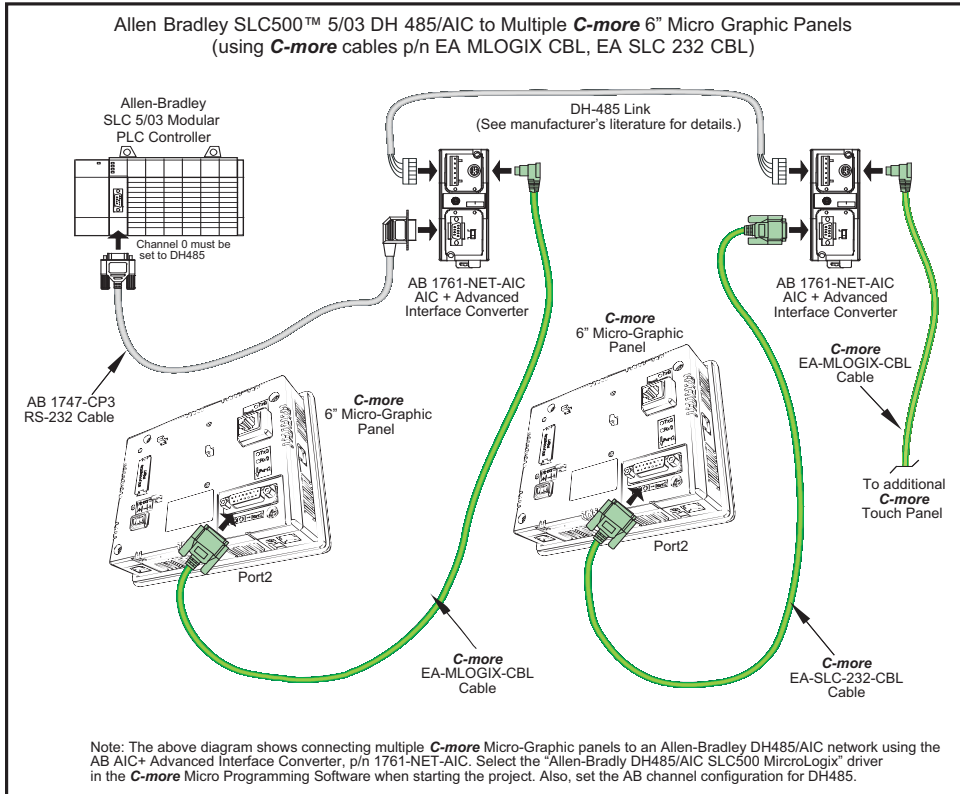

Cables from AutomationDirect - Wiring Diagrams (cont'd)

GE:

EA-90-30-CBL

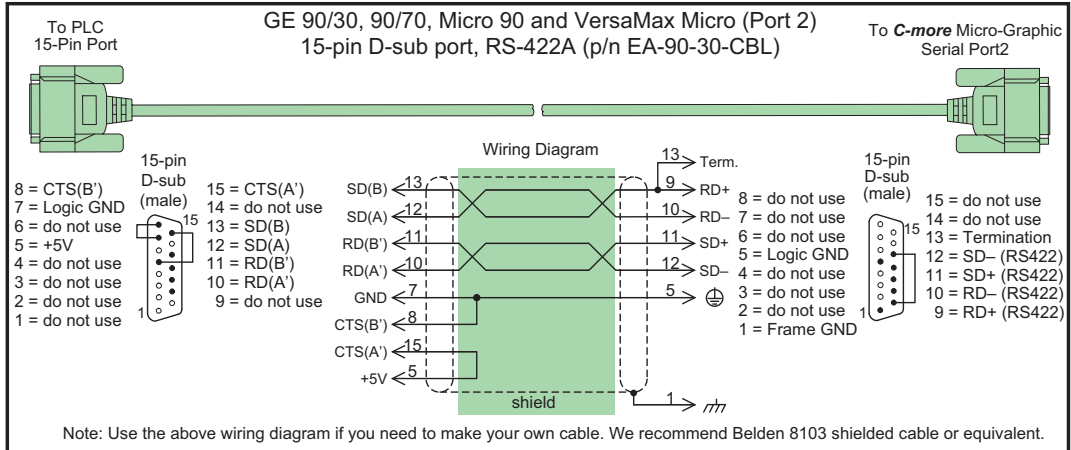

Mitsubishi:

EA-MITSU-CBL

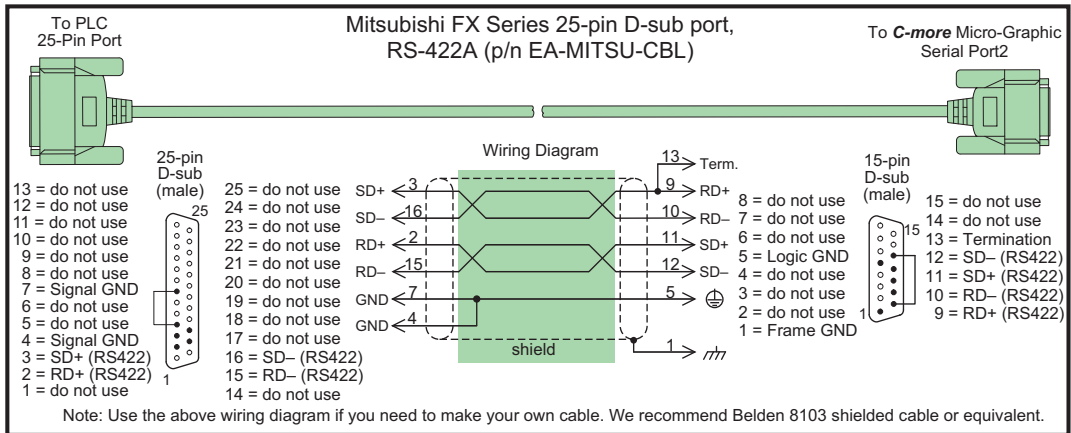

Cables from AutomationDirect - Wiring Diagrams (cont'd)

Mitsubishi:

EA-MITSU-CBL-1

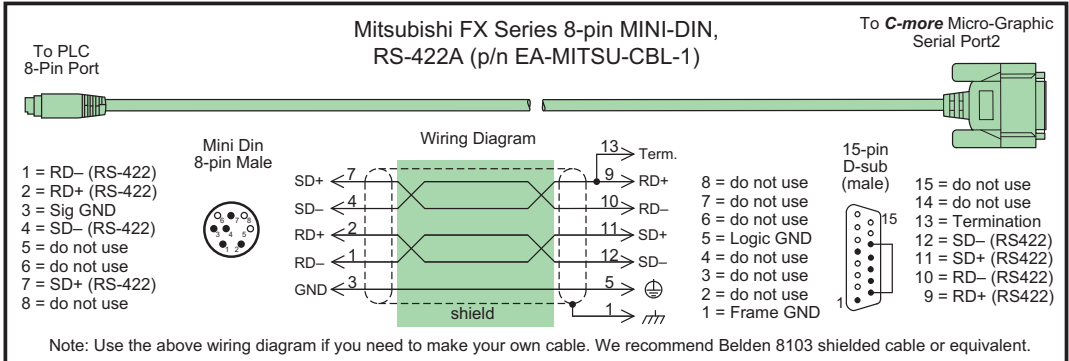

6

Omron:

EA-OMRON-CBL

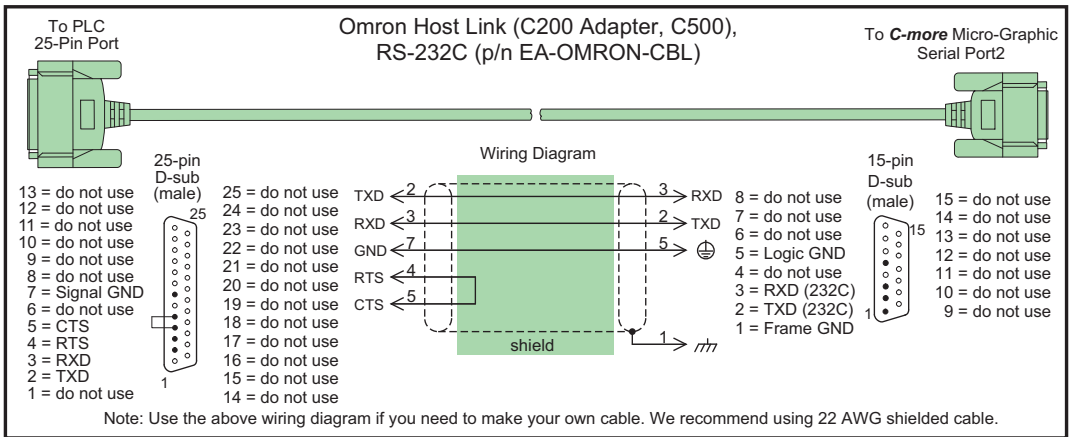

User Constructed Cables – Wiring Diagrams

Diagram 1

User Constructed

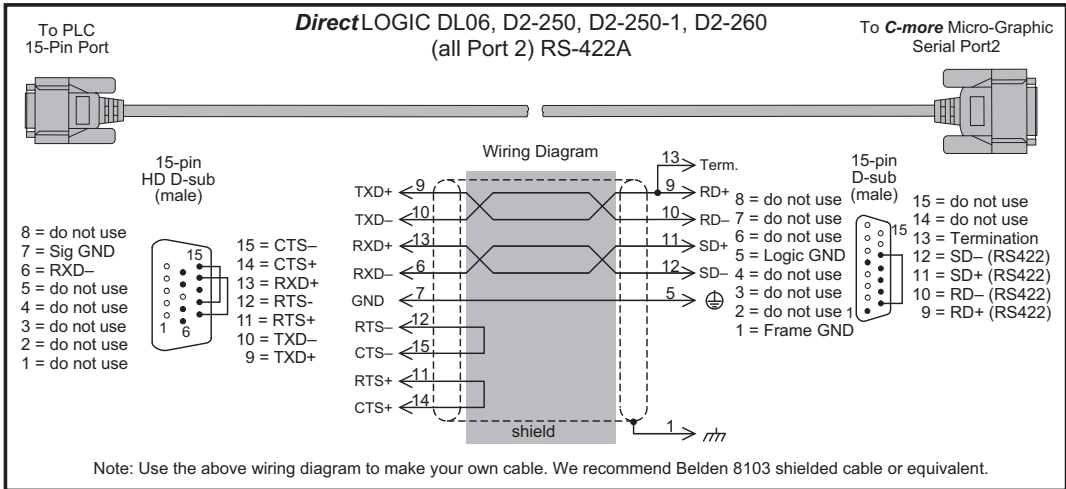
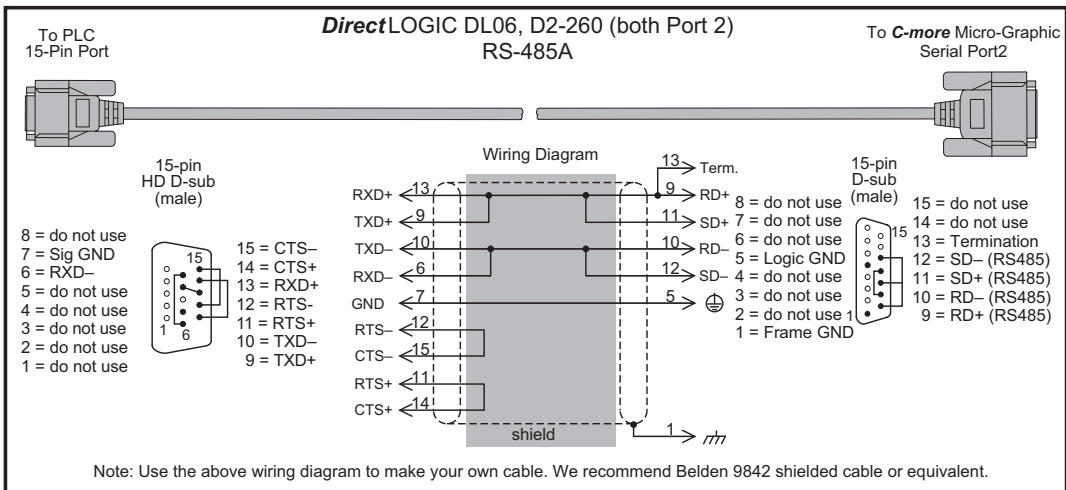

Diagram 2

User Constructed



NOTE: The RS-422 and RS-485 wiring diagrams shown above are not for multi-drop networks involving connecting more than one PLC to a panel. Refer to the wiring diagram examples starting on page 6-38 if more than one PLC will be connected to a panel.

User Constructed Cables – Wiring Diagrams (cont'd)

Diagram 3

User Constructed

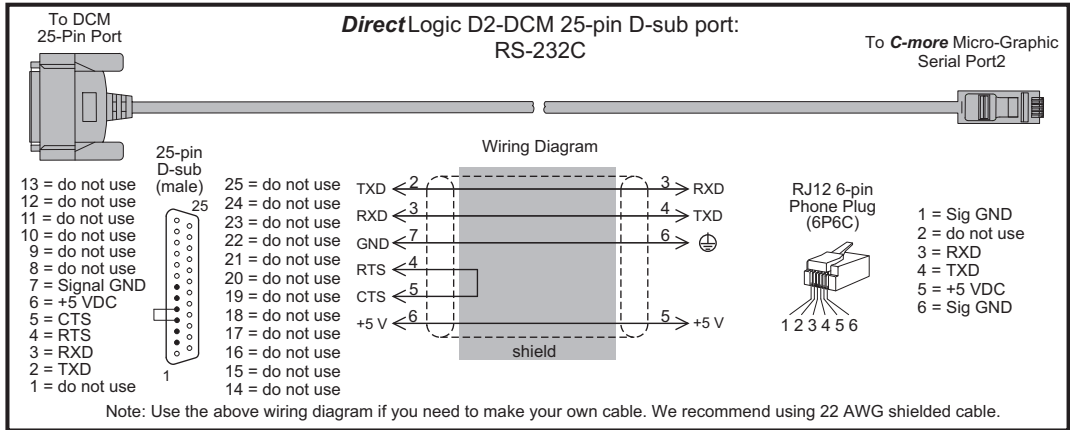

6

Diagram 4

User Constructed

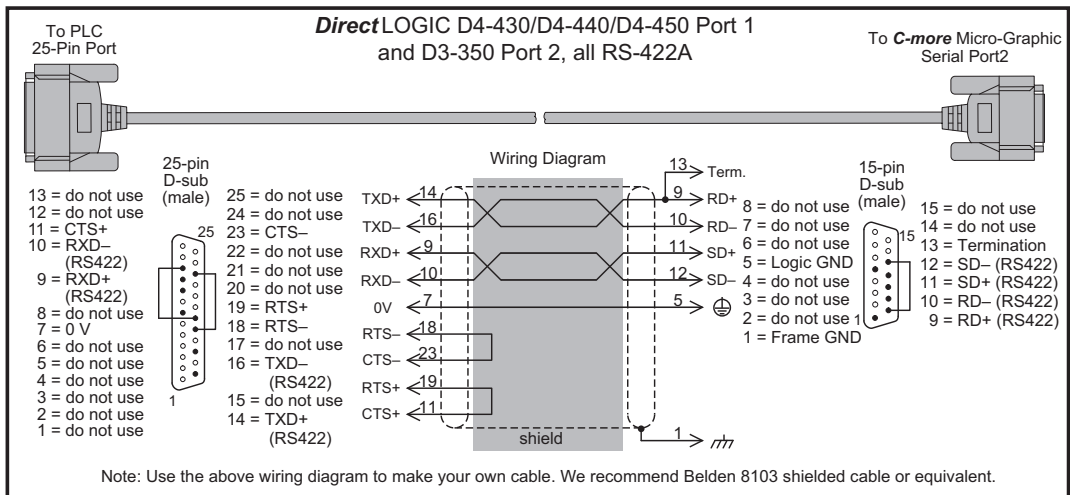

NOTE: The RS-422 wiring diagram shown above is not for multi-drop networks involving connecting more than one PLC to a panel. Refer to the wiring diagram example on page 6-38 if more than one PLC will be connected to a panel.

User Constructed Cables – Wiring Diagrams (cont'd)

Diagram 5

User Constructed

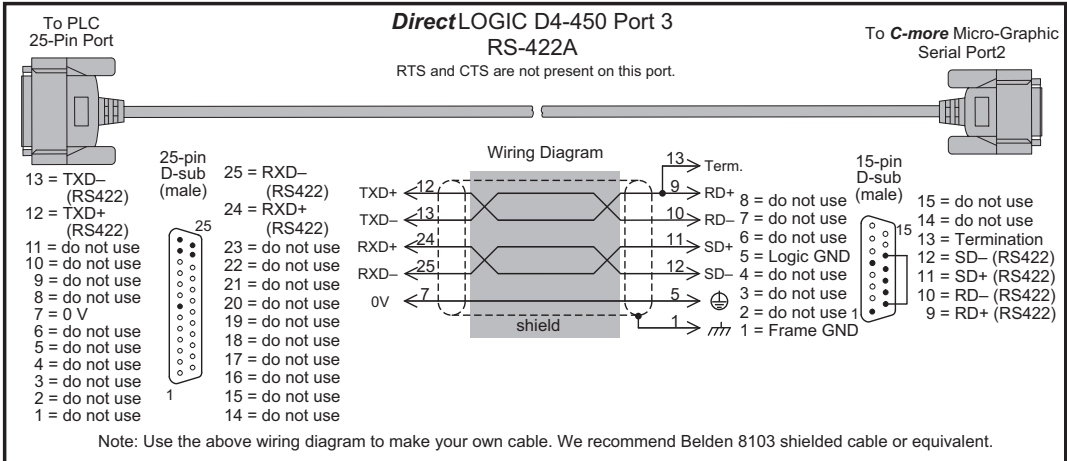
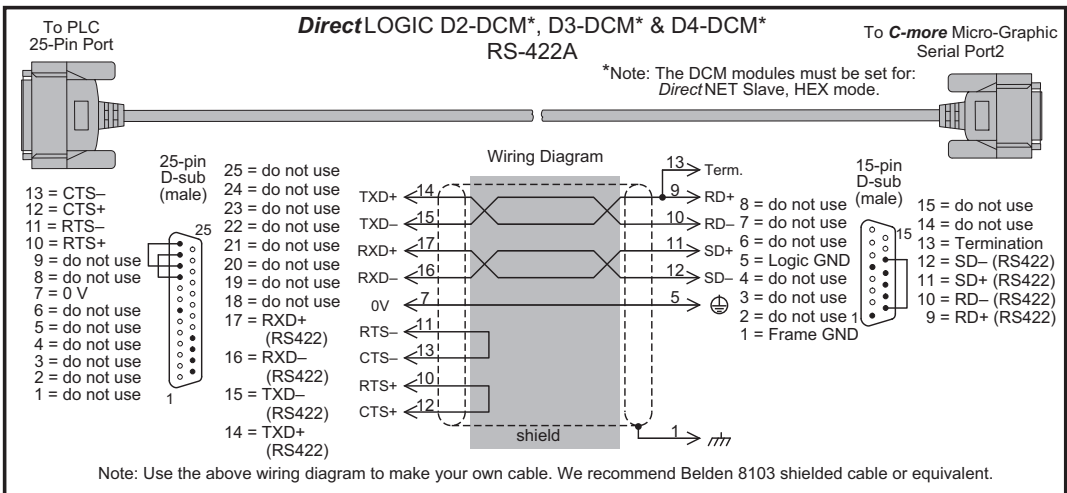

Diagram 6

User Constructed



NOTE: The RS-422 wiring diagrams shown above are not for multi-drop networks involving connecting more than one PLC to a panel. Refer to the wiring diagram example on page 6-38 if more than one PLC will be connected to a panel.

User Constructed Cables – Wiring Diagrams (cont'd)

Diagram 7

User Constructed

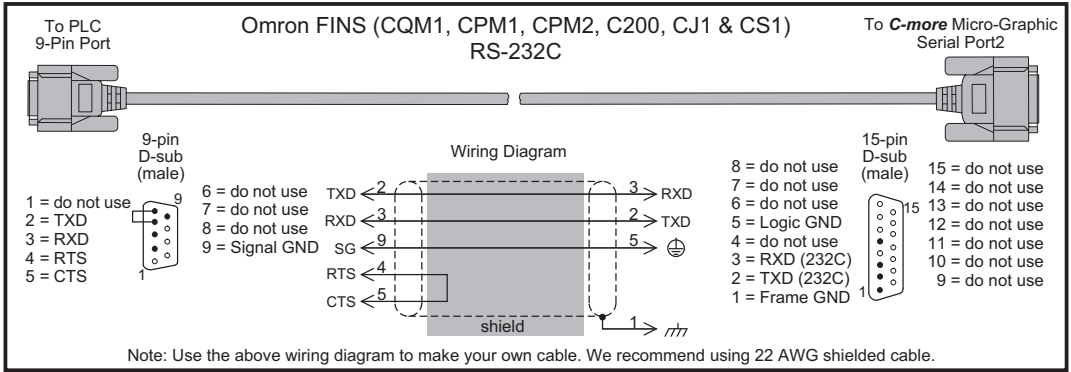

6

Diagram 8

User Constructed

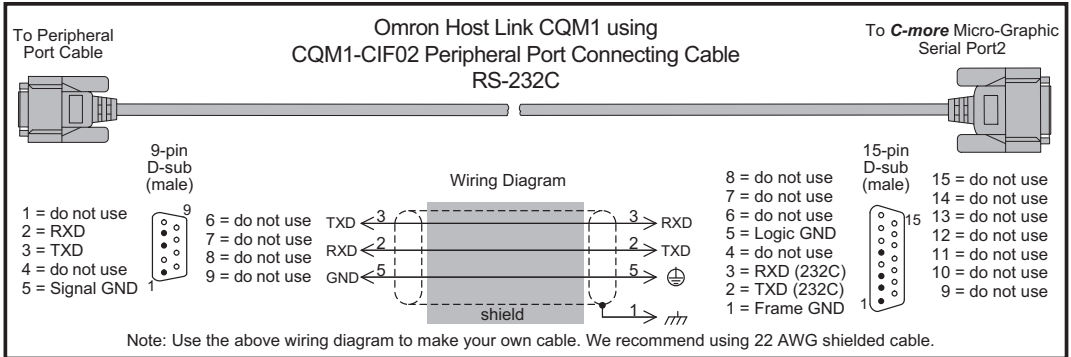
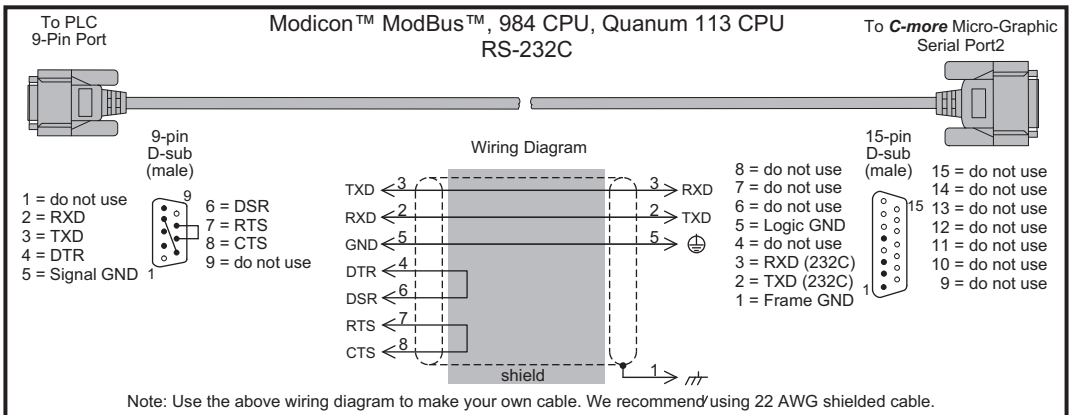

Diagram 9

User Constructed



User Constructed Cables – Wiring Diagrams (cont'd)

Diagram 10

User Constructed

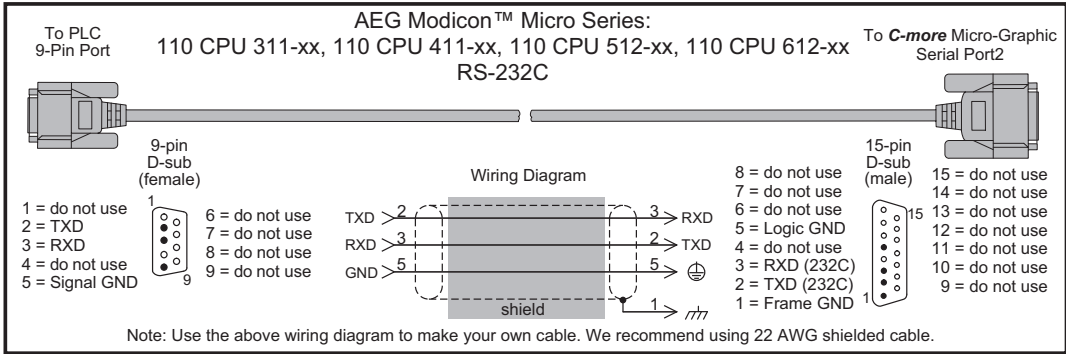

Diagram 11

User Constructed

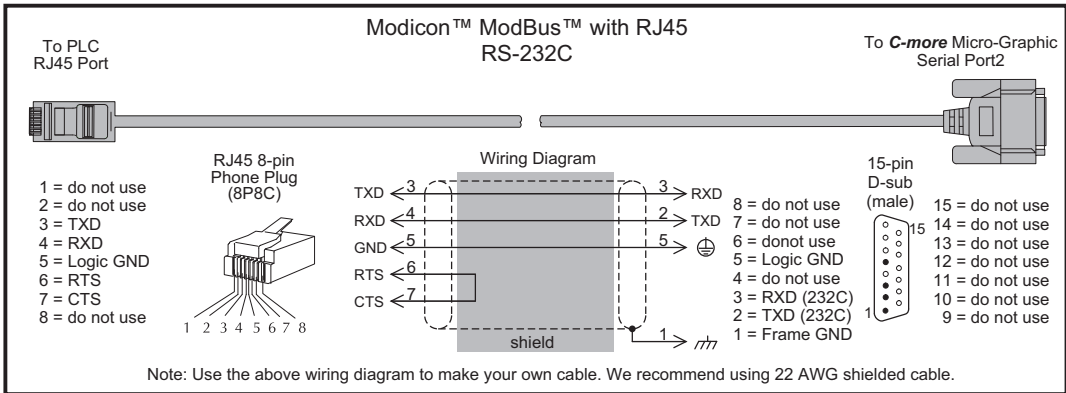
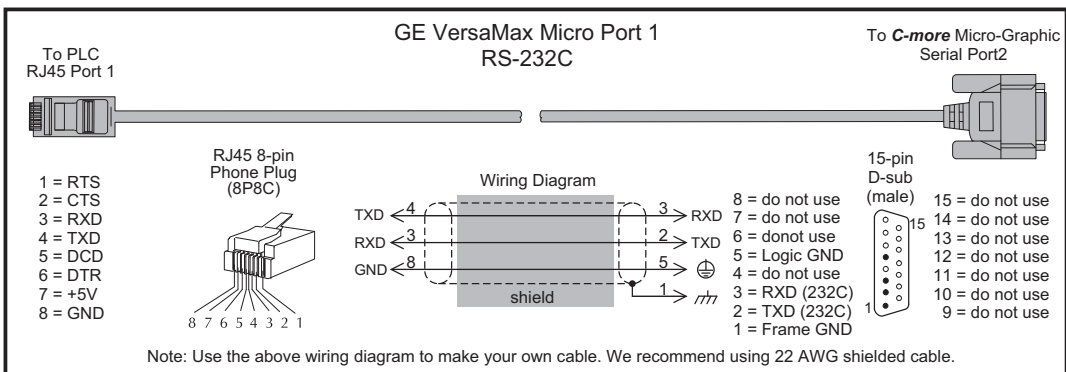

Diagram 12

User Constructed



User Constructed Cables – Wiring Diagrams (cont'd)

Diagram 13

User Constructed

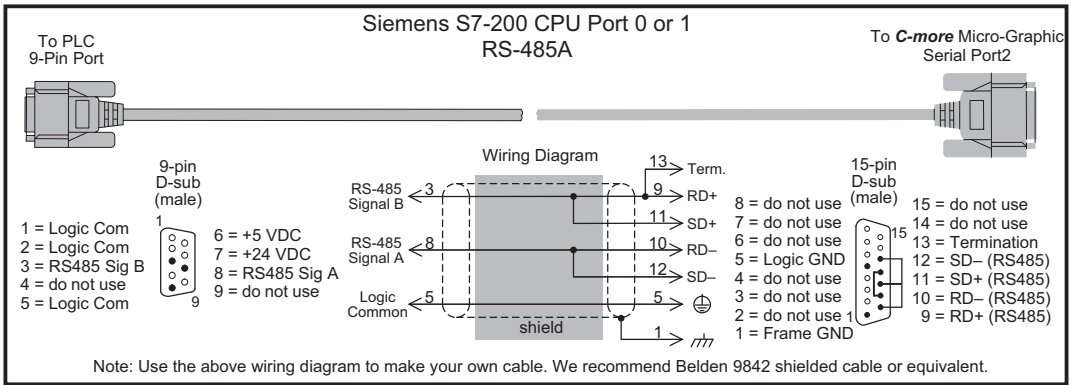

6

Diagram 14

User Constructed

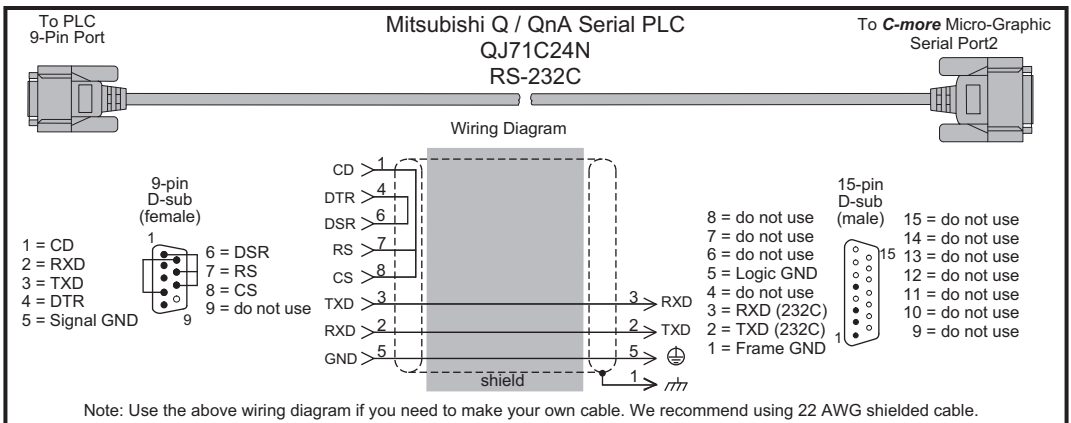
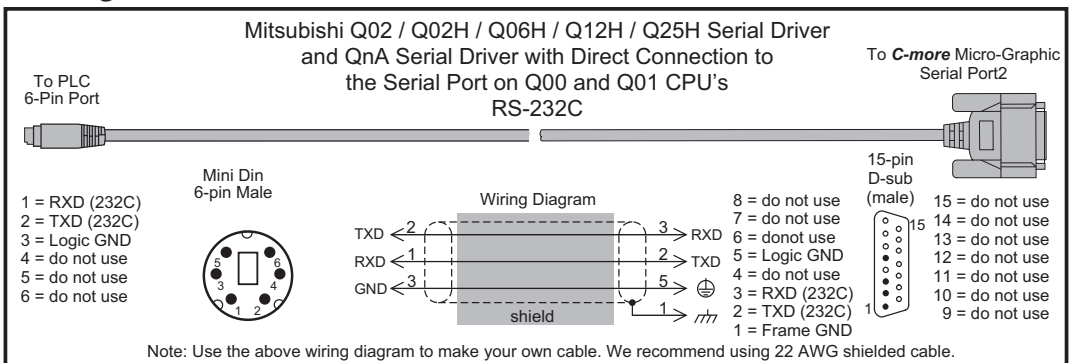

Diagram 15

User Constructed



RS-422A/RS-485A Multi-Drop Wiring Diagram Examples

6

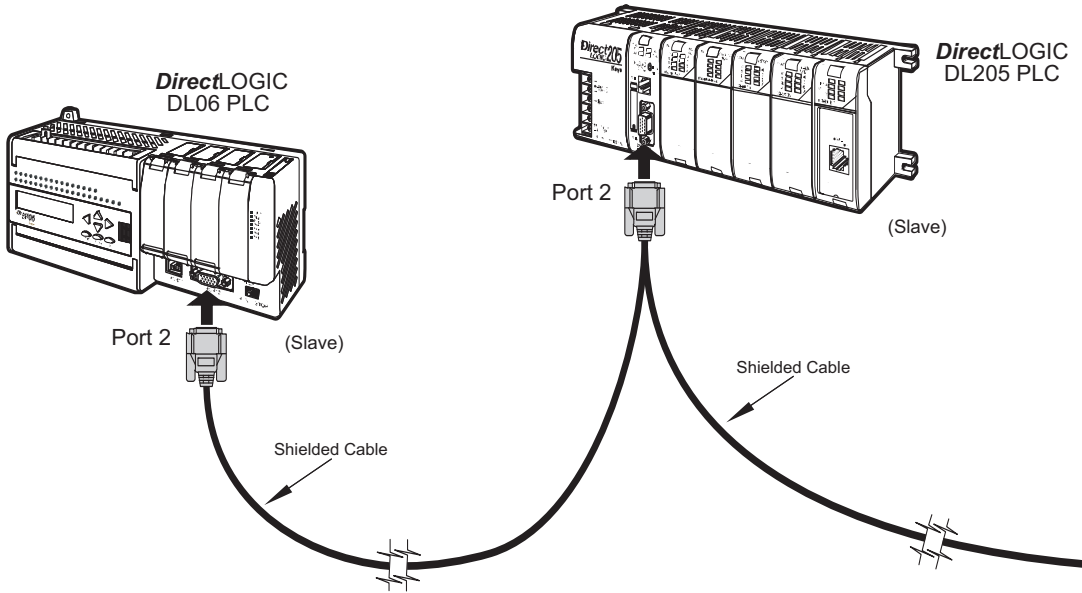

Note: We recommend Belden 8103 shielded cable or equivalent.

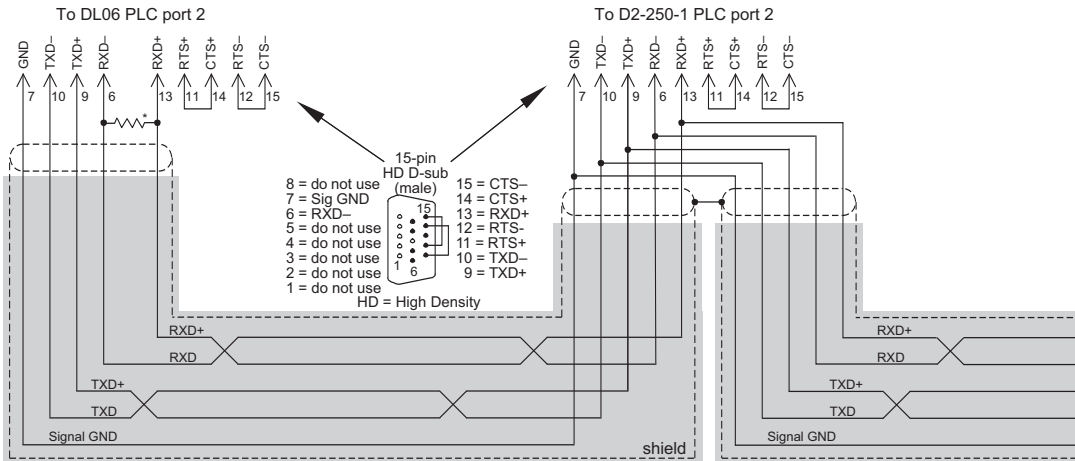

* Termination resistors required at both ends of the network receive data signals to match the impedance of the cable (between 100 and 500 ohms).

Typical RS-422 Multi-Drop Wiring Diagram

RS-422A/RS-485A Multi-Drop Wiring Diagram Examples (cont'd)

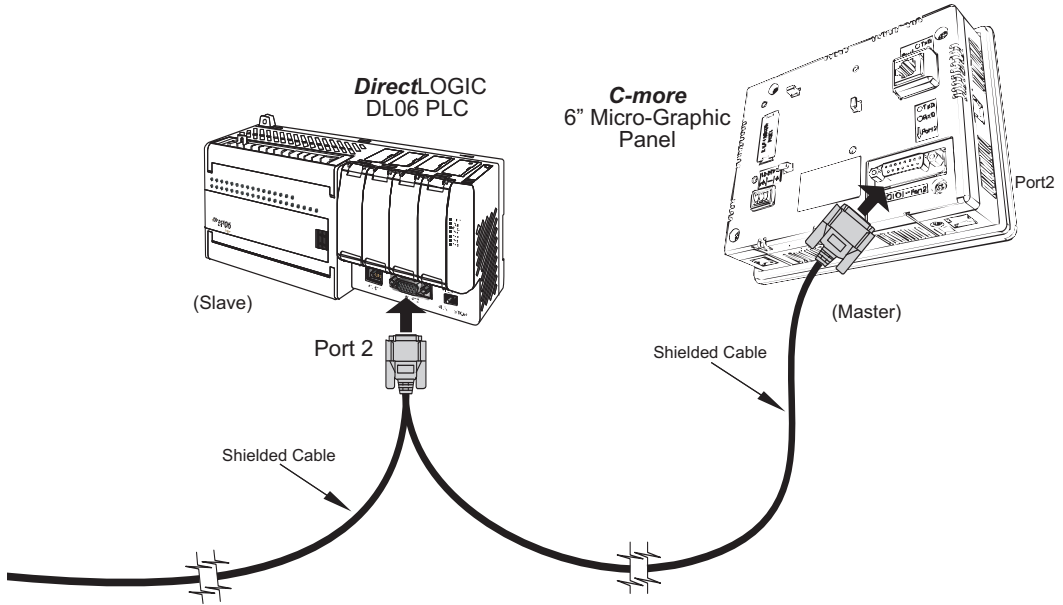

Note: We recommend Belden 8103 shielded cable or equivalent.

6

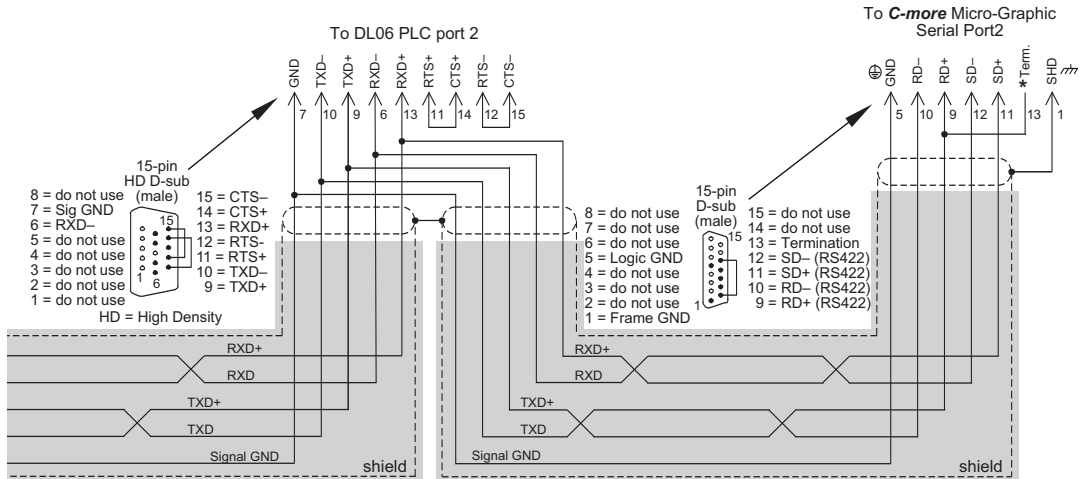

* Termination resistors required at both ends of the network receive data signals to match the impedance of the cable (between 100 and 500 ohms). Jumper pin 13 to 9 on the C-more 6" Micro-Graphic Serial Port2 15-pin connector to place the 120Ω internal resistor into the network. If the cable impedance is different, then use an external resistor matched to the cable impedance.

Typical RS-422 Multi-Drop Wiring Diagram (cont'd)

RS-422A/RS-485A Multi-Drop Wiring Diagram Examples (cont'd)

6

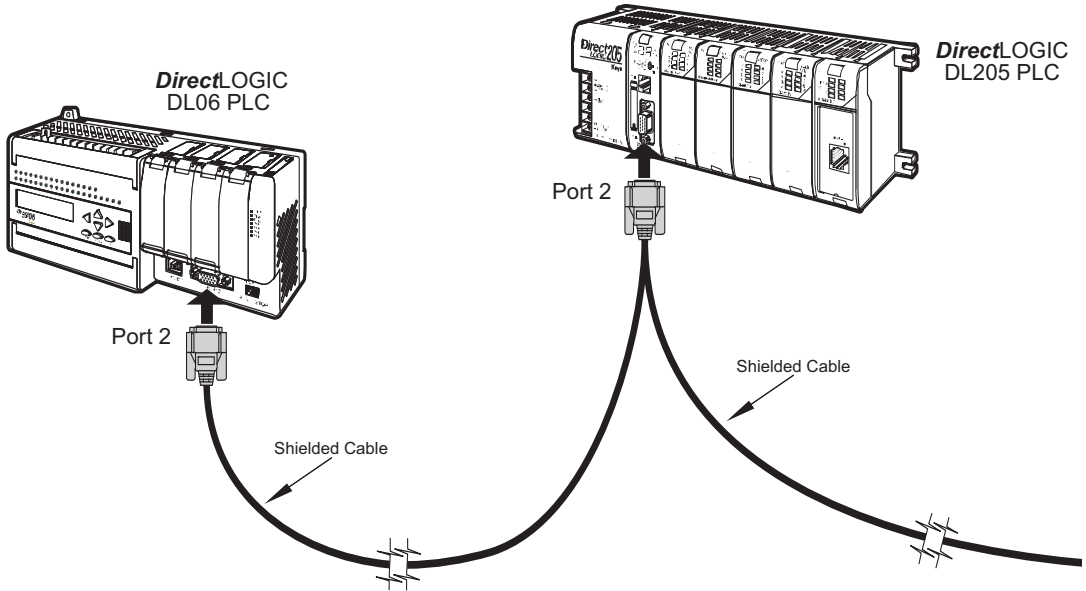

Note: We recommend Belden 88102 shielded cable or equivalent.

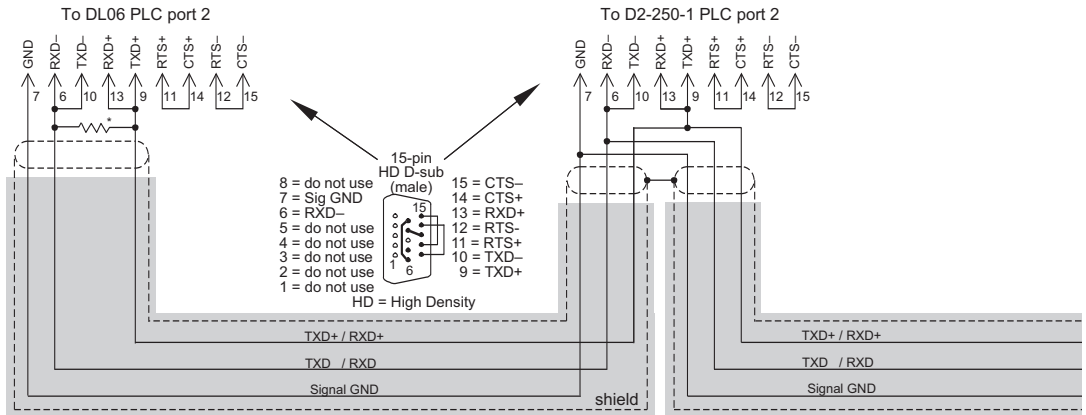

* Termination resistors required at both ends of the network to match the impedance of the cable (between 100 and 500 ohms).

Typical RS-485 Multi-Drop Wiring Diagram

RS-422A/RS-485A Multi-Drop Wiring Diagram Examples (cont'd)

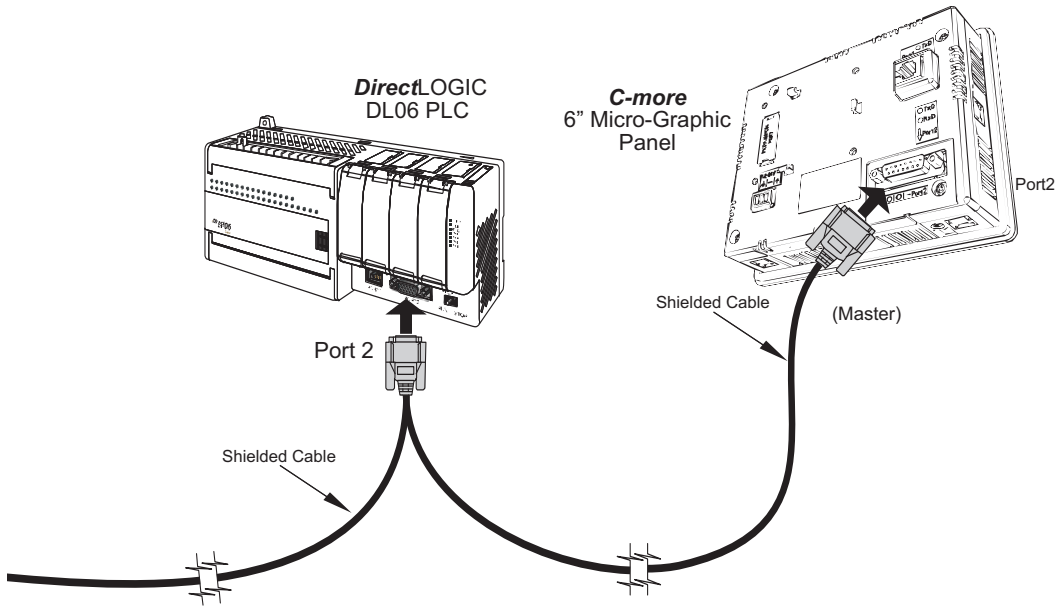

Note: We recommend Belden 88102 shielded cable or equivalent.

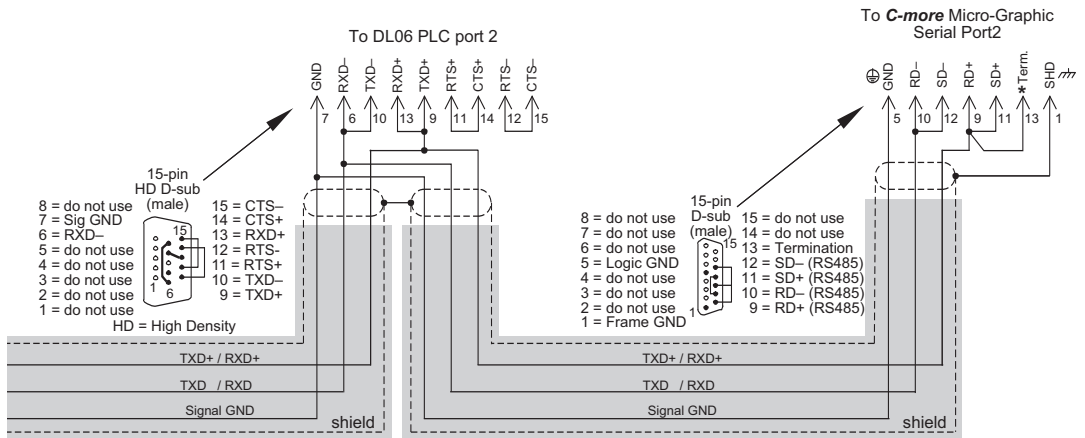

Typical RS-485 Multi-Drop Wiring Diagram (cont'd)

* Termination resistors required at both ends of the network receive data signals to match the impedance of the cable (between 100 and 500 ohms). Jumper pin 13 to 9 on the C-more 6" Micro-Graphic Serial Port2 15-pin connector to place the 120Ω internal resistor into the network. If the cable impedance is different, then use an external resistor matched to the cable impedance.

MAINTENANCE



CHAPTER 7

In This Chapter...

Project Backup	7-2
Check Operating Environment	7-2
Check Operating Voltage	7-2
Check Transmit and Receive Indicators	7-3
Check Physical Conditions	7-3
Run Tests under the System Setup Screens	7-4
Check Settings under the System Setup Screens	7-5
Cleaning the Display Screen	7-5
Check Project Functionality	7-6
Checks from the <i>C-more</i> Micro-Graphic Programming Software	7-6

Maintenance



Although the *C-more*® 6" Micro-Graphic panels require very little maintenance, setting up a routine maintenance schedule will insure the longevity of the product in your application.

The following are some suggestions of items to include in a preventive maintenance list or schedule. Most of these items should be scheduled quarterly or bi-annually.

Project Backup

During a routine preventive maintenance schedule is a good time to make sure that there is an up-to-date backup of the application project.

Check Operating Environment

Make sure the *C-more* Micro-Graphic panel is operating in the proper temperature range: (0 to 50 °C (32 to 122 °F)).



Make sure the *C-more* Micro-Graphic panel is operating within the specified humidity range: (5–95% RH, non-condensing).



Make sure the operating environment is free of corrosive vapors and gasses.



Check Operating Voltage

Check the input voltage that is powering the *C-more* Micro-Graphic panel to make sure it is within the appropriate range.



5 VDC: If the panel is being powered with 5 VDC from an AUTOMATIONDIRECT PLC's RJ12 serial communications port to Port 1 on the panel, the acceptable voltage range to the panel is 4.75-5.25 VDC (1.05 W @ 5 VDC (210 mA)).

24 VDC: If the panel is being powered from an external power source the acceptable voltage range to the panel is 10.2-26.4 VDC (6.5W @ 10.2 VDC (630mA)).



NOTE: When the panel is powered through Port1 from a connected PLC or PC, the screen brightness is diminished because the panel is running in **Low-Power Mode**. For full brightness, connect an external 12-24 VDC power source to the panel's power connection. **Low-Power Mode** is intended for initial programming. For full brightness, connect an external 12-24 VDC power source when the panel is installed in its application.

Check Transmit and Receive Indicators

During a routine maintenance check is a good time to take a quick look at the status indicators on the back of the *C-more 6*” Micro-Graphic panel. There should be activity on both the TxD and RxD LED indicators when connected serially to a PLC or control device from either port and data is being updated on the screen.

C-more 6” Micro-Graphic Panel Communication Ports Status Indicators

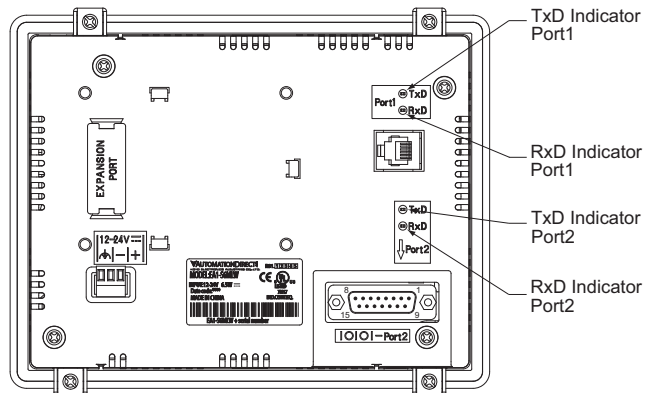

7

Check Physical Conditions

Make sure that harmful chemicals are not being used around the *C-more 6*” Micro-Graphic panel. Look for any deterioration of the panel’s bezel and front display area. See **Chapter 2: Specifications** for a chemical compatibility list.

Check the mounting gasket to make sure it is sealing properly and has not deteriorated. Replace the mounting gasket if there are any signs of deterioration, or if there is any evidence that moisture/liquids have penetrated to the inside of the enclosure where the panel is mounted. Information on replacement gaskets can be found in **Chapter 9: Replacement Parts**.

Check to make sure that none of the cooling vents around the inside section of the *C-more* Micro-Graphic panel are clogged with dust or debris. Also make sure that there is clearance around the panel as shown in **Chapter 4: Installation and Wiring**.

Run Tests under the System Setup Screens

Use the *C-more* 6" Micro-Graphic panel's System Setup Screens to test communication ports, PLC connectivity, the internal beeper and touch screen operation. See **Chapter 5: System Setup Screens** for additional details.

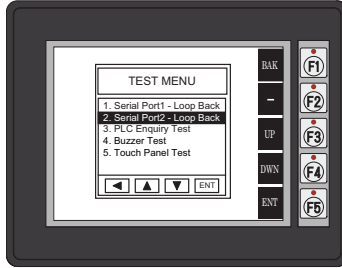

Serial Port1 - Performs a test to verify the RJ12 serial communications port (Port 1) on the panel is operating correctly. Requires a loop back connector inserted into the port to properly run the test. A wiring diagram for the loop back connector is shown below.

Serial Port2 - Performs a test to verify either the RS-232 or the RS485/422 serial communications functionality from the 15-pin connector (Port 2) on the panel is operating correctly. A loop back connector inserted into the port is required for proper testing. Wiring diagrams for RS-232 and RS-485/422 loop back connectors are shown below.

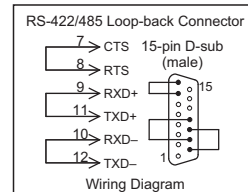
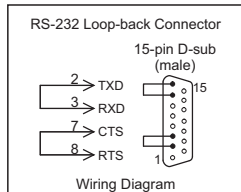
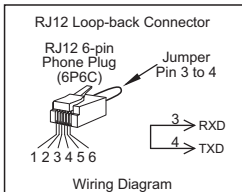

PLC Enquiry Test - Tests the communications with the selected PLC protocol between the panel and a connected PLC. Is used with both Port1 and Port2.

Buzzer Test - Use this option to test the internal audible beeper of the panel.



Touch Panel Test - Tests the response of the touch screen area to contact. This test is used to make sure the touch screen area is responding properly.



NOTE: Only one of the ports can be used with a connected PLC. The programming software allows the user to select either Port1 or Port2 under the Panel Manager dialog box. When using Port2 to communicate with the connected PLC, Port1 can still be used with the EA-MG-PGM-CBL Software Programming Cable Assembly to transfer projects between the PC and panel.

Check Settings under the System Setup Screens

Use the *C-more* 6" Micro-Graphic panel's System Setup Screens to check the various settings such as the LCD contrast, background color, beep and orientation. See **Chapter 5: System Setup Screens** for additional details.

LCD Contrast - Used to adjust the LCD display's contrast. The default is a value of 8, and the range is 1 to 16, with 16 being the highest contrast. Adjust as necessary.

Beep - Used to enable or disable the internal audible beeper. the default is beep on.

Calibration - Used to calibrate the touch screen on the panel.

Cleaning the Display Screen

The display screen should be cleaned periodically by wiping it with a lint free damp cloth using a mild soap solution. Dry the surface when finished with a lint free cloth. Do not use cleaning solvents (ammonia, alcohol, acetone, etc.) which may damage the plastic housing and touch screen.

The longevity of the touch screen can be increased by the use of a **EA-6-COV2** clear screen overlay. See **Chapter 3: Accessories** for additional information on the screen overlay.

To prevent damage to the touch screen, avoid touching the screen with sharp objects, striking the screen with a hard object, using abrasives on the screen, or using excessive force when pressing the touch screen.

Check Project Functionality

During a routine maintenance schedule is a good time to check the functionality of your application, making sure that various areas on different screens do what they were designed to do. An outline or specification for the application is a useful tool for testing the various aspects of your application. As a starting point, you may want to run through all the screens to make sure they are accessible.

If there are any trouble-shooting procedures programmed into the *C-more 6* Micro-Graphic panel application, now is a good time to also check these aids.

Checks from the *C-more* Micro-Graphic Programming Software

If you have a PC available with the *C-more* Micro-Graphic Programming Software, EA-MG-PGMSW, installed, and the panel is connected to the PC, you can check the status of the panel from the **Panel Information** window.

The **Panel Information** window shown below will indicate the panel type, if a keypad bezel has been installed, the total memory, memory used, free memory, firmware version, mask ROM version, and the PLC protocol selected for its serial communication ports. The programming software can also be used to update the panel's firmware to the latest version.

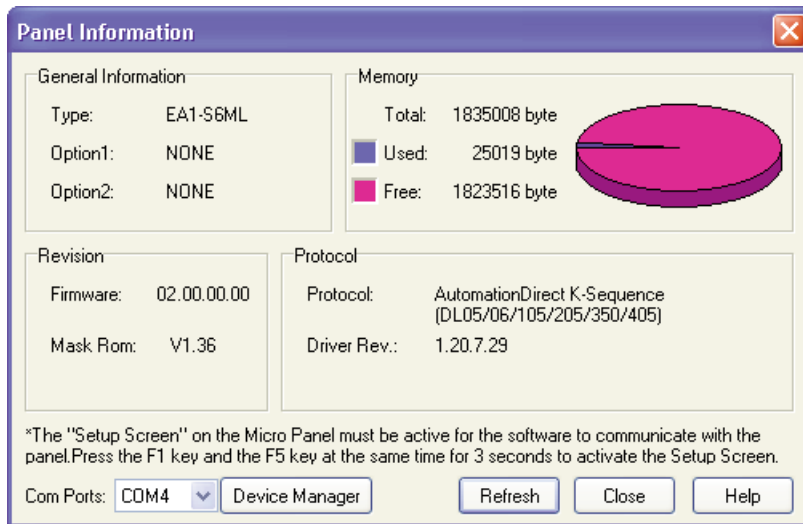

TROUBLESHOOTING



CHAPTER 8

In This Chapter...

<i>C-more 6" Micro-Graphic Panel does not Power up</i>	8-2
Display is Blank	8-2
Display is Dim	8-3
No User Program	8-3
Lost Firmware – Red 'Update Mode' Screen Displayed	8-4
Updating Firmware	8-4
No Communications between Panel and PC (Personal Computer)	8-5
No Communications between Panel and PLC	8-7
Panel & PLC Error Codes	8-8
<i>C-more Micro-Graphic Panel Runtime Errors</i>	8-9
Electrical Noise Problems	8-10

Troubleshooting



The following are some problems that may be encountered during the installation and operation of your *C-more*® Micro-Graphic panel. We have made some suggestions on what to check in order to correct the problem.

C-more 6" Micro-Graphic Panel does not Power up

Powered from 5 VDC: If the panel's display is blank, not responding, and the panel is powered from a 5 VDC power source such as a PC or PLC, check the incoming DC voltage level with a voltmeter. The DC voltage level should be in the range of 4.75 to 5.25 VDC. If the incoming DC voltage is zero, check any fusing that may be in the circuit. If the fuse is open, determine cause and replace.

Powered from 12-24 VDC: If the panel's display is blank, not responding, and the panel is powered from a 12-24 VDC power source, check the incoming DC voltage level to the adapter with a voltmeter. The DC voltage level to the adapter should be in the range of 10.2-26.4 VDC. If the incoming DC voltage is zero, check any fusing that may be in the circuit. If the fuse is open, determine cause and replace.

Display is Blank

Also if the panel's display is blank, check the TxD and RxD indicators on the back side of the panel while the panel is communicating with the PLC. The LED indicators should be on or flashing at a fast rate. Indicator activity shows that the panel is communicating with the PLC. If there is communication activity, but the display is still blank, there is the possibility the program in the PLC is controlling the display. Try pressing the F1 and F5 keys simultaneously for 3 seconds. The panel will change to the System Setup Screen menu if the screen is being forced to display a blank screen by the PLC program. Also, check the PLC program, it may have the screen in the off state by placing a 0 in the current screen tag.

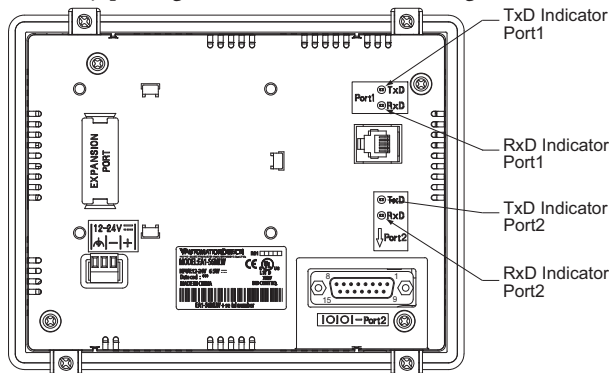

NOTE: When the panel is powered through Port1 from a connected PLC or PC, the screen brightness is diminished because the panel is running in **Low-Power Mode**. For full brightness, connect an external 12-24 VDC power source to the panel's power connection. **Low-Power Mode** is intended for initial programming. For full brightness, connect an external 12-24 VDC power source when the panel is installed in its application.

Display is Dim



NOTE: When the panel is powered through Port1 from a connected PLC or PC, the screen brightness is diminished because the panel is running in **Low-Power Mode**. For full brightness, connect an external 12-24 VDC power source to the panel's power connection. **Low-Power Mode** is intended for initial programming. For full brightness, connect an external 12-24 VDC power source when the panel is installed in its application.

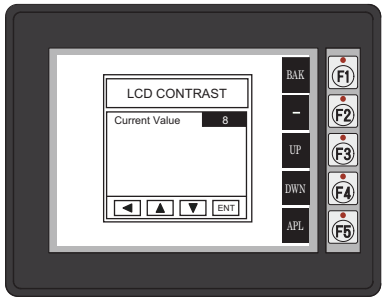
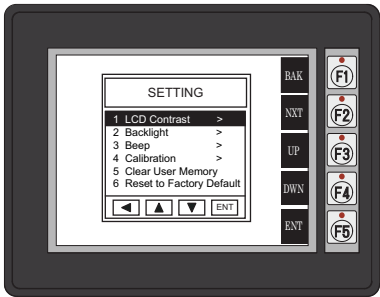

Press the F1 and F5 keys simultaneously for 3 seconds and the panel will bring up the the System Setup Screen menu. Select the Setting menu, and then select item 1; LCD Contrast. The default value is 8. Adjust the current value from 1 to 16 and the panel's contrast should become greater as the value moves toward 16 and it should become less as the value moves toward 1. If this does not happen, then the panel may need to be replaced. See note above.

LCD Contrast: The contrast of LCD has 16 levels of adjustment. The default is a value of 8.

No User Program

If the panel is displaying the message "No User Program" after it is powered up, then there is no project downloaded into the panel. Using the EA-MG-PGMSW *C-more* Micro-Graphic Programming Software, download your project to the panel.

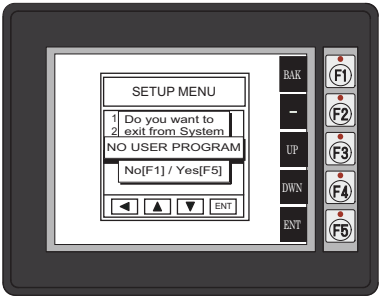

Lost Firmware – Red ‘Update Mode’ Screen Displayed

If the *C-more* Micro-Graphic panel's firmware becomes corrupted or for some reason is lost from the panel's memory, the panel will display the **Update Mode** screen as shown below. This can happen if communication between the PC and the panel is interrupted during a firmware update. To resolve the problem, try the following steps in the order shown:

- 1.) Cycle power to the panel.
- 2.) If the problem persists, update the firmware to the panel using the **Update Firmware** utility under the **Panel** pull down menu in the EA-MG-PGMSW Programming Software.
- 3.) If the problem persists, depress function keys F1 and F5 while cycling power to the panel. The panel should come up in the red **Update Mode** screen as shown below. Perform Step 2 again.
- 4.) If there is still a problem, call Tech Support @ 770-844-4200.

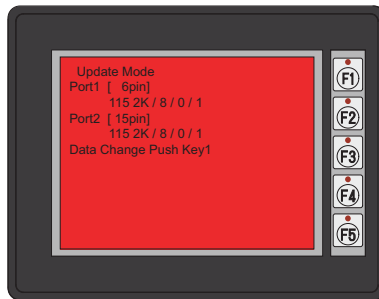

Updating Firmware

The panel firmware version must match both the programming software version and the version that the program was saved as. If a version needs to be updated, for example, to take advantage of new functionality or product line additions follow these steps:

- 1.) Create a backup copy of the project on the PC. From the *C-more* Micro-Graphic programming software, read the project from the panel and save to a desired location.
- 2.) Update the programming software on the PC.
- 3.) Cycle power to the panel.
- 4.) Update the firmware to the panel using the **Update Firmware** utility under the **Panel** pull down menu in the EA-MG-PGMSW Programming Software.
- 5.) Open the project in the updated programming software. Save the project. Transfer the project to the panel.

No Communications between Panel and PC (Personal Computer)

There are three possible causes that prevent transferring the project to the *C-more* Micro-Graphic panel.

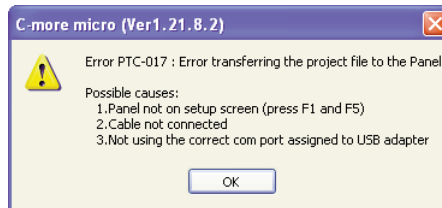

1. **Panel not on setup screen (press F1 and F5)** - Press and hold the F1 and F5 buttons simultaneously for three seconds to enter the setup screen.
2. **Cable not connected** - Double check the programming cable assembly to make sure the panel is correctly connected to the USB port on the PC.

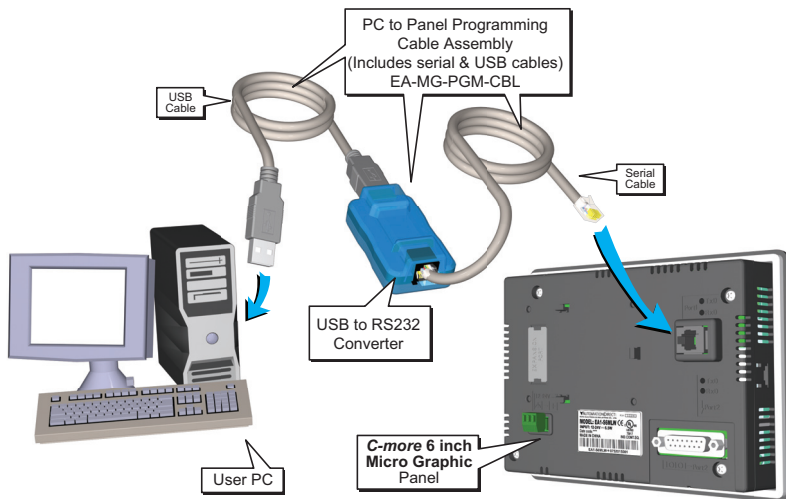

NOTE: When properly installed the programming cable will look like a serial communications port to the PC.

No communications between panel and PC continued top of next page.

No Communications between Panel and PC (Personal Computer) (cont'd)

3. Not using the correct COM port assigned to the USB adapter - If the *C-more* Micro-Graphic panel is on the setup screen and the cable connection is correct, then check the PC COM port setting.

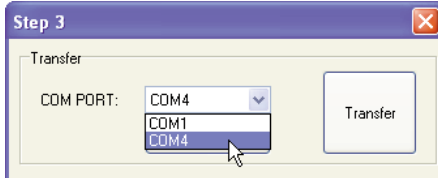

If you are unsure which COM port the *C-more* Micro-Graphic programming cable is connected to, click on the **Device Manager** button. This will open Windows ® **Device Manager**.

In the **Device Manager** window, view the active ports by clicking the + button beside the Ports (COM & LPT) menu item. The *C-more* Micro-Graphic panel uses a USB driver called **Koyo USB-Serial Comm Port**.

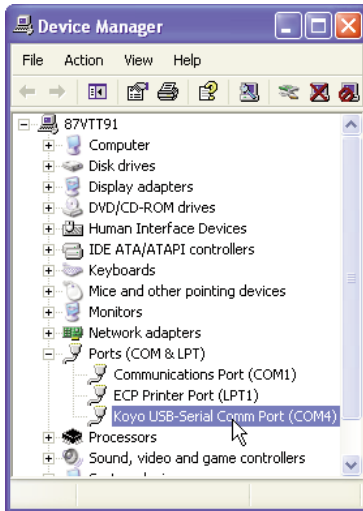
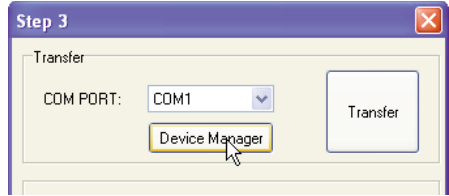

COM4 is the USB port used in this example. If you cannot find the **Koyo USB-Serial Comm Port** under Ports (COM & LPT) in **Device Manager**, the USB driver may not be correctly installed or the driver has a problem. Disconnect the cable from the PC and follow these steps to re-install the driver:

- Uninstall the *C-more* Micro-Graphic programming software.
- Unplug the cable between the PC and the *C-more* Micro-Graphic panel.
- Re-install the *C-more* Micro-Graphic programming software. Make sure the install USB driver checkbox is selected.

If you have selected the correct COM port and the error still occurs, try connecting the programming cable to a different USB port on the PC and try again.

If the problem persists, call Technical Support at (770) 844-4200, available from 9:00 A.M. to 6:00 P.M. Eastern Time.

No Communications between Panel and PLC

The *C-more* Micro-Graphic panel communicates with a designated PLC or controlling device through the panel's RS-232 RJ12 serial communications port (Port1) or RS-232 / RS-485 / RS-422 communications port (Port2).

Check the Txd and Rxd status indicators of the port connected to the PLC. The indicator LED's should be on or flashing at a fast rate. If there is activity on the LED indicators, then the panel and PLC are communicating.

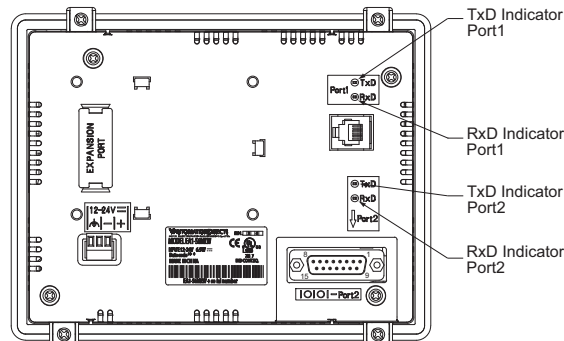

On either serial communications port, if there is no activity on one or both TxD and RxD LED status indicators, then it should be suspected that either:

- The communication settings are incorrect - Open Panel Manager in the *C-more* Micro-Graphic programming software and verify that the correct panel Comm. Port is selected. Verify that the correct PLC protocol is selected and properly configured.

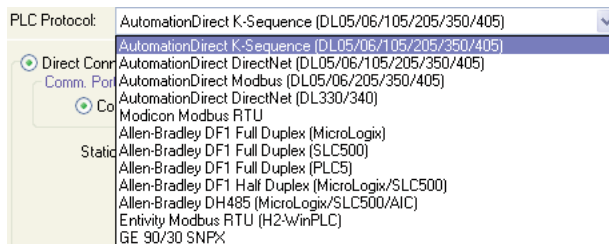

- The cable is bad and needs to be replaced - Try a proven cable.
- Test panel serial port. See Chapter 5, Serial Port - Loop Back Test. If the panel's serial port is defective and if a cable is available, switch to the other port on the panel. If possible switch the panel with a panel that is communicating properly.
- The serial port on the PLC is defective

Electrical noise, pulse generating wiring and/or improper grounding can also cause problems with communications. Refer to the Electrical Noise Problems section in this chapter for additional help if electrical noise is suspected. Selecting a lower communication rate in Panel Manager may help the panel resist noise.

Panel & PLC Error Codes

The *C-more* Micro-Graphic panel includes built-in PLC communication protocol diagnostics that monitor the exchange of data between the panel and the PLC. The diagnostics look for the proper exchange of data, correct handshaking signals, addressing errors, incorrect data bytes, wrong packet format, etc. The diagnostics also monitor and display any of the errors that the designated PLC generates if there is a problem with the PLC's communications. The PLC generated errors are interpreted by the *C-more* Micro-Graphic programming software and are displayed across the top of the panel's display embedded as a hexadecimal value in error code P499.

If a *C-more* Micro-Graphic communication error does occur, the error message will be displayed in the upper left of the panel's display screen along with the error code number. The error code with error message will blink off and on. .



NOTE: See *Appendix A: Panel & PLC Error Code Tables* for a complete list of all error codes.

Panel Communications Error Code Example

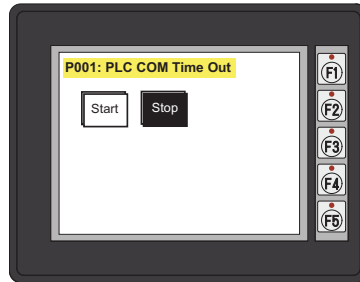

C-more Micro-Graphic Panel Runtime Errors

The *C-more* Micro-Graphic panel includes built-in diagnostics that check for proper operation of the panel when it is running a project that has been transferred to its memory. Faults detected while the panel is running will produce a “Runtime” error. These errors are displayed in a popup window in the center of the panel’s display.

Troubleshooting a Panel Runtime Error:

Follow these steps to troubleshoot a panel runtime error.

1. Check the panel cable connections.
2. Cycle power at the panel.
3. Resend the project.
4. If the error still occurs, reset the panel back to factory default. Refer to Chapter 5 for details



NOTE: User memory is cleared when factory defaults are reset. Use the *C-more* Micro-Graphic programming software to read the program from the panel and save a backup copy.

Panel Errors

If more than one panel error occurs, each error message will display sequentially for three seconds with a two second delay between each message.

When only one panel error is active, that message will display continuously until it is no longer active.

Micro-Graphic Panel Errors		
Error Code	Error Message	Possible Solutions
R001	PC software tool Timeout	Check cables and connections. Cycle power at the panel. See Chapter 8 for Electrical Noise Problems.
R002	CRC Error occurred during project transfer from PC.	Check the area for sources of noise: electrical motors, transformers, etc. Check for proper grounding Resend the project.
R003	Project Check Sum Error. Resend Project file to Panel.	Cycle power. Resend the project.
R004	Protocol Module Check Sum Error. Resend Project File to Panel	
R005	Panel Check Sum Error. Panel Info (Not Project) will be initialized.	From the Setup Menu screen, reset panel options.
R006	SW Ver. Mismatch. Use software Ver.xx xx.	Update to current version programming software and panel firmware.
R100	Option module detected without external power	EA-MG-SP1 or EA-MG-P1 optional power adapter module is installed on a C-more 3" Micro-Graphic panel without a 12-24 VDC power source. Provide 12-24 VDC power to the optional module.
R101	Unsupported module detected	EA-MG-SP1 or EA-MG-P1 optional power adapter module for a C-more 3" Micro-Graphic panel is installed on a C-more 6" Micro-Graphic panel. Remove the EA-MG-SP1 or EA-MG-P1.

Electrical Noise Problems

Most noise problems result from improper grounding of the system. A good earth ground can be the single most effective way to correct noise problems. If a ground is not available, install a ground rod as close to the system as possible. Ensure all ground wires are single point grounds and are not daisy chained from one device to another. Ground metal enclosures around the system. A loose wire can act as a large antenna, introducing noise into the system. Therefore, tighten all connections in your system. Loose ground wires are more susceptible to noise than the other wires in your system. Review **Chapter 4: Installation & Wiring** if you have questions regarding how to ground the touch panel.

Electrical noise can enter the system through the power source for the touch panel. Installing a properly wired isolation transformer (neutral grounded) for all AC sources can help the problem, but only if wired correctly. DC sources should be well-grounded good quality supplies.

Never run communication cables or low-voltage power wiring close to high voltage wiring or pulse generating wiring that controls such devices as solenoids, servos, VFOs, etc.

Selecting a lower communication rate in Panel Manager may help the panel resist noise.

REPLACEMENT PARTS



In This Chapter...

Replacement Parts Overview	9-2
Replacement Parts	9-2
Customizing the Function Keys Insert Label	9-3

Replacement Parts Overview

Part Number	Description
EA-MG-BZ2-BRK	Replacement mounting clip for <i>C-more</i> 6" Micro-Graphic panel and keypad bezels (pk of 8)
EA-MG-DC-CON	Replacement adapter DC power connector (pk of 5)
EA-MG6-S6ML-GSK	Replacement mounting gasket for <i>C-more</i> 6" Micro-Graphic panels
EA-MG6-BZ2-GSK	Replacement mounting gasket for <i>C-more</i> 6" Micro-Graphic keypad bezels EA-MG-BZ2(P)
EA-MG-S6ML-FKL	Replacement function key label insert for <i>C-more</i> 6" Micro-Graphic panels (pk of 5; 3 blank, 1 F1-F5 for landscape, 1 F1-F5 for portrait)
EA-6-COV2	Clear Screen Overlay (pk of 3)

Replacement Parts

Mounting Clips for 6" panel or bezel

Part No. EA-MG-BZ2-BRK



(pk of 8)

DC Power Connector

Part No. EA-MG-DC-CON



(pk of 5)

Panel Gasket

Part No. EA-MG6-S6ML-GSK



Function Keys Label Inserts

Part No. EA-MG6-S6ML-FKL

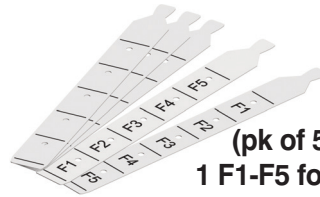

(pk of 5; 3 blank,
1 F1-F5 for landscape,
1 F1-F5 for portrait)

Keypad Bezel Gasket

Part No. EA-MG6-BZ2-GSK

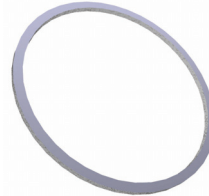

Clear Screen Overlay

EA-6-COV2

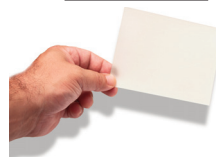

(pk of 3)

9

Customizing the Function Keys Insert Label

Step 1 - Remove existing function key label insert using a small tool such as jeweler's screw driver.



Step 3 - If desired, print and apply self adhesive labels to the blank insert.



Step 2 - Remove the protective film from the blank key label insert.

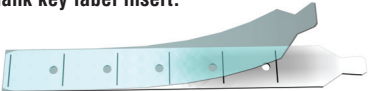

Step 4 - Install the new insert into the slot in the side of the panel and lock tab into place.

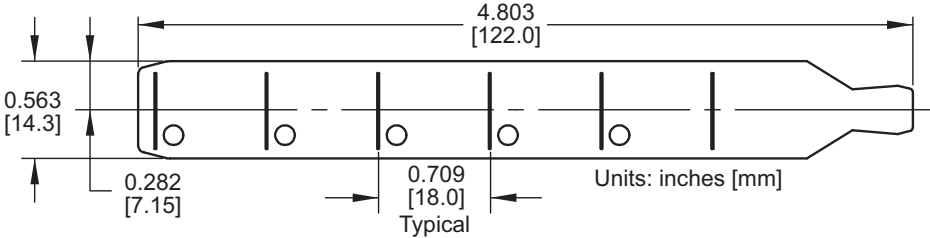
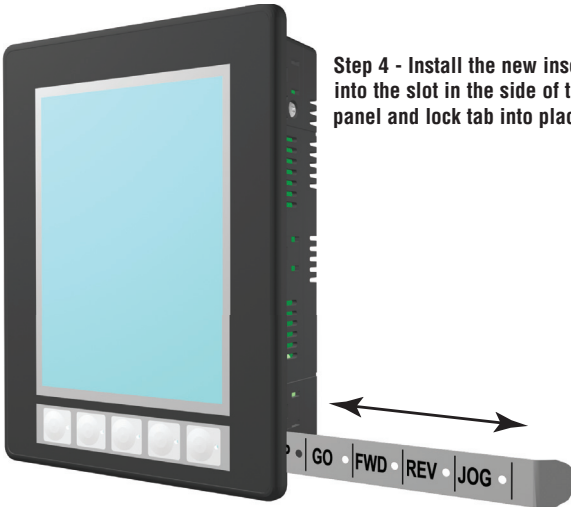

PANEL & PLC ERROR CODE TABLES



In This Appendix...

Introduction	A-2
<i>C-more</i> Micro-Graphic Panel Error Code Table	A-3
Modbus Protocols Error Code P499 Explanation	A-4
AutomationDirect CLICK	A-4
AutomationDirect <i>Direct</i> LOGIC - Modbus (Koyo)	A-4
Modicon Modbus RTU	A-4
Entivity Modbus RTU	A-4
<i>Direct</i> LOGIC Error Code P499 Explanation	A-5
<i>Direct</i> LOGIC – K-Sequence PLC Error Code Table	A-5
<i>Direct</i> LOGIC – <i>Direct</i> NET PLC Error Codes	A-5
Allen-Bradley Error Code P499 Explanation	A-6
Allen-Bradley DF1 Protocol – PLC Error Code Tables	A-7
Allen-Bradley DH485 Protocol – PLC Error Code Tables	A-9
GE Error Code P499 Explanation	A-11
GE SNPX Protocol – PLC Error Code Tables	A-12
Mitsubishi FX Protocol – PLC Error Codes	A-21
Mitsubishi Q / QnA and Q Series – PLC Error Codes	A-21
Omron Error Code P499 Explanation	A-23
Omron Host Link Protocol – PLC Error Code Table	A-24
Omron FINS Protocol – PLC Error Code Table	A-25
Siemens Error Code P499 Explanation	A-28
Siemens PPI Protocol – PLC Error Code Table	A-29

Introduction

The *C-more*[®] Micro-Graphic panels are capable of communicating over RS232, RS422 and RS485 serial networks. They communicate with CLICK PLC's, all controllers in the *Direct LOGIC* family of PLCs utilizing various protocols and certain 3rd party PLCs. For a complete list of the supported PLCs and protocols, see the PLC Drivers table in **Chapter 6: PLC Communications**.

As with any network communications, errors may occur. To simplify identification of the possible cause of the error, we have provided tables listing these errors. If a *C-more* Micro-Graphic panel communications error, or other related data exchange error does occur, the error message will appear across the top of the display screen as shown in the example below. A complete table of the panel generated errors, with their respective error codes, error messages, and the possible causes of the error follows.

The *C-more* Micro-Graphic panel also monitors any errors that are generated by the PLC that is connected to it. If any of the PLC generated errors are detected, they are displayed across the top of the panel's display embedded as a hexadecimal value in error code P499. An explanation of how the specific PLC error is identified in the panel error code P499 is shown preceding the specific manufacturer's PLC error tables. How the hexadecimal error code value is interpreted is slightly different between manufacturers, so it is important to check the explanation at the beginning of each manufacturer's tables. Since these errors are generated by the PLC, refer to the PLC manufacturers documentation for further explanation.

If you have difficulty determining the cause of the error, please refer to **Chapter 8: Troubleshooting** for some troubleshooting tips or contact our technical support group at 770-844-4200.

C-more Micro-Graphic Panel Error Example

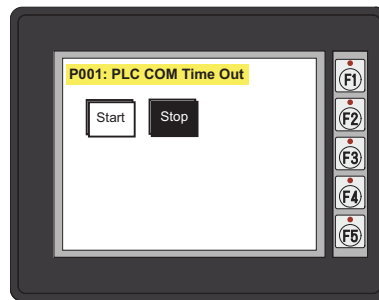

C-more Micro-Graphic Panel Error Code Table

The following table includes all of the error codes and error messages that the panel will display if the listed cause is detected. All of these errors involve problems that could result with the panel communicating with the connected PLC. Be aware that not all of the panel errors are used with each type of PLC that can be connected to the panel.

<i>C-more</i> Micro-Graphic Panel Error Table		
Error Code	Error Message	Cause
P001	PLC Com Time Out	A timeout occurred after sending a request to the PLC.
P002	NAK Received	A negative acknowledgement (NAK) control code has been generated during a read/write request.
P003	EOT Received	An end of transmission has been sent by PLC in response to a read/write/setbit request.
P004	STX is Not Found	A Start of Text (STX) control code was not found in the data packet received from the PLC.
P005	ETX/ETB NotFound	Neither an End of Text (ETX) nor an End of Transmission Block (ETB) control code was found in the data packet received from the PLC.
P006	LRC Not Match	There was an incorrect Longitudinal Redundancy Check (LRC) control code in the communications packet received from the PLC. This is an indication that the data in the packet is corrupted.
P007	CRC Not Match	There was an incorrect Cyclic Redundancy Check (CRC) control code in the communications packet received from the PLC. This is an indication that the data in the packet is corrupted.
P008	Address NotMatch	The address value returned in the data packet from the PLC is incorrect.
P009	Re.INV.FUN.Code	The function code returned in the data packet from the PLC is incorrect.
P010	DataSizeNotMatch	There are an incorrect number of bytes found in the data packet returned from the PLC.
P011	INV.Val.FUN.Code	There is an invalid value in the function code.
P012	INVALID COMMAND	There was an invalid command sent to the PLC that wasn't recognized by the PLC.
P013	ENQ Received	If the data packet does not include a negative acknowledgement (NAK - 0x15 value) in the defined packet field, then an enquiry (ENQ) control code error will be displayed.
P014	TransID NotMatch	This error will be displayed if after checking the Transaction ID Byte in the data packet, there is no match to what was requested.
P015	Device Not Found	A PLC device designated as Device could not be found.
P016	DataByte Com.Err	The data part of the packet received contains 0 bytes of data.
P017	Out of Add.Range	The touch panel requested a file number larger than 255.
P019	Parity Error	Parity error occurred.
P021	PLC# Not Match	PLC Number does not match
P023	Not Connected	Cable not connected properly
P024	No Other Dev.	Cannot detect other devices
P025	PollingListErr.	Panel not in polling list
P028	No Response	PLC failed to Respond: %PLC Node#%??

C-more Micro-Graphic Panel Error Code Table continued on the next page.

C-more Micro-Graphic Panel Error Code Table (cont'd)

A

C-more Micro-Graphic Panel Error Table (cont'd)		
Error Code	Error Message	Cause
P499*	ErrCode Received -> Recv .Err Code XXXX	A PLC generated error code with a hexadecimal value of XXXX has been returned from the PLC. * See the explanation for error code P499 proceeding each set of PLC error code tables.
P500	Can'tWriteS.Port	Data cannot be written to the Serial port. Data was sent to the PLC via the Serial Port. If this error shows on the Panel, it indicates a Hardware Problem.
P700	RD.Buff.MEM Full	There was an error while allocating memory for the read buffer. When this error is displayed, a memory leak may have occurred.
P701	INV.PLC Address	Request to inaccessible memory from the HMI layer to the PLC protocol layer. This error is an indication that there is a problem in the HMI layer.
P702	INV.FUN.Code	A Read/Write/SetBit request has been sent to an invalid memory area. This error is an indication that there is a problem in the HMI layer.
P703	WRT.PLC.ReadOnly	A PLC Write request was made to the PLC's Read-Only memory area. This error is an indication that there is a problem in the HMI layer or the PLC protocol layer.

Modbus Protocols Error Code P499 Explanation

The following table lists the errors that can be generated by the Modbus protocols:

AutomationDirect CLICK

AutomationDirect DirectLOGIC - Modbus (Koyo)

Modicon Modbus RTU

Entivity Modbus RTU



Note: The following errors can be generated from the designated PLC, are monitored by the C-more Micro-Graphic panel, and displayed on the panel's screen as a hexadecimal value in panel error code P499, if active.

PLC Error Codes Modbus Protocols		
Panel Error Code P499 Hex Value	Name	Meaning
0x0001	ILLEGAL FUNCTION	The function code received in the query is not an allowable action for the server (or slave). This may be because the function code is only applicable to newer devices and was not implemented in the unit selected. It could also indicate that the server (or slave) is in the wrong state to process a request of this type, for example because it is unconfigured and is being asked to return registered values.
0x0002	ILLEGAL DATA ADDRESS	The data address received in the query is not an allowable address for the server (or slave). More specifically, the combination of reference number and transfer length is invalid. For a controller with 100 registers, the PDU addresses the first register as 0, and the last one as 99. If a request is submitted with a starting register address of 96 and a quantity of registers of 4, then the request will successfully operate (address-wise at least) on registers 96, 97, 98, 99. If a request is submitted with a starting register of 96 and a quantity of registers of 5, then the request will fail with Exception code 0x02 "Illegal Data Address" since it attempts to operate on registers 96, 97, 98, 99 and 100, and there is no register with address 100.
0x0003	ILLEGAL DATA VALUE	A value contained in the query data field is not an allowable value for server (or slave). This indicates a fault in the structure of the remainder of a complex request, such as that the implied length is incorrect. It specifically does NOT mean that a data item submitted for storage in a register has a value outside the expectation of the application program, since the Modbus protocol is unaware of the significance of any particular value of any particular register.
0x0004	SLAVE DEVICE FAILURE	An unrecoverable error occurred while the server (or slave) was attempting to perform the requested action.

DirectLOGIC Error Code P499 Explanation

The P499 error code is used to show any errors that are generated by the connected PLC. The P499 error message includes a four digit hexadecimal value displayed at the end of the message. This value can be found in the specific PLC's error tables to determine the cause of the error. The possible PLC generated error codes for the various *Direct* LOGIC communication protocols breakdown into a four digit hexadecimal value.

*Direct*LOGIC PLC Error Code Displayed Example:

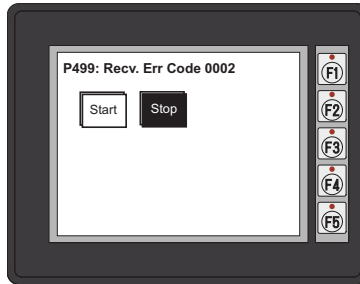

DirectLOGIC – K-Sequence PLC Error Code Table

The following table lists the errors that can be generated by the *Direct*LOGIC PLC when using the K-Sequence protocol.



Note: The following errors can be generated from the designated PLC, are monitored by the *C-more* Micro-Graphic panel, and displayed on the panel's screen as a hexadecimal value in panel error code P499, if active. Please refer to the PLC users manual for additional information.

PLC Error Codes for <i>Direct</i> LOGIC – K-Sequence	
Panel Error Code P499 Hex Value	Description
01F8	Error setting value.
020D	Error in key mode.
021C	Password protected.

DirectLOGIC – DirectNET PLC Error Codes

There are no PLC generated errors that occur when using the *Direct*NET protocol.

A

Allen-Bradley Error Code P499 Explanation

The P499 error code is used to show any errors that are generated by the connected PLC. The P499 error message includes a four digit hexadecimal value displayed at the end of the message. This value can be looked up in the specific PLC's error tables to determine the cause of the error. The possible PLC generated error codes for the Allen-Bradley DF1 and DH485 communication protocol is represented by a hexadecimal value as shown in the following diagram. Please note that the error code is broken down into three sections. It is possible for more than one type of PLC error to be displayed in this value.

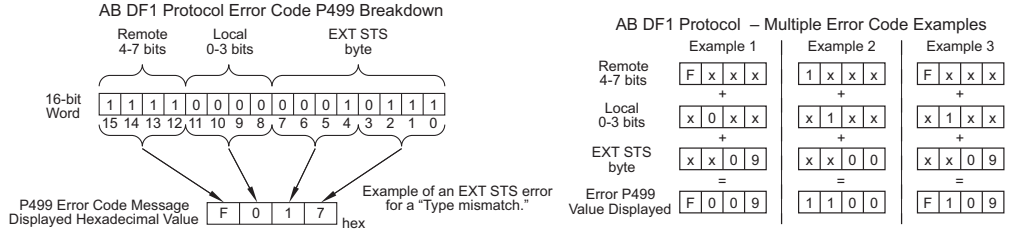

Allen-Bradley PLC Error Code Displayed Example

Error Received = P499: Recv. Err Code 3200

Remote = 0x3000 = Remote node host is missing, disconnected or shut down.

Local - 0x0200 = Cannot Guarantee Delivery; Link Layer. The remote node specified does not ACK Command

EXT STS = 0000 = None

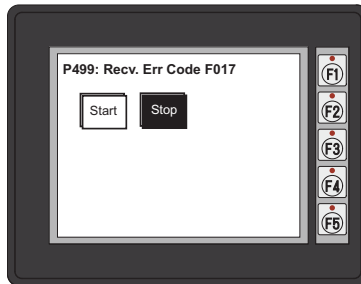
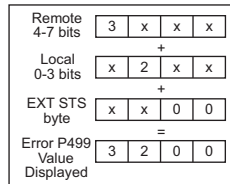

Allen-Bradley DF1 Protocol – PLC Error Code Tables

The following PLC error tables cover possible errors that are detected by the panel from Allen-Bradley PLCs using the DF1 protocol. This includes full and half duplex communications for the MicroLogix 1000, 1100, 1200 & 1500, SLC 5/03, /04, /05, ControlLogix, CompactLogix and FlexLogix, and full duplex communications for the PLC5.



Note: The following errors can be generated from the designated PLC, are monitored by the **C-more** Micro-Graphic panel, and displayed on the panel's screen as a hexadecimal value in panel error code P499, if active. Please refer to the PLC users manual for additional information.

PLC Errors for Allen-Bradley DF1 Protocol, Remote STS Errors (4-7 bits)

Panel Error Code P499 Hex Value	Description
0x0	Success; no error.
0x10	Illegal command or format.
0x20	Host has a problem and will not communicate.
0x30	Remote node host is missing, disconnected, or shut down.
0x40	Host could not complete function due to hardware fault.
0x50	Addressing problem or memory protect rungs.
0x60	Function not allowed due to command protection selection.
0x70	Processor is in Program Mode.
0x80	Compatibility mode file missing or communication zone problem.
0x90	Remote node cannot buffer command.
0xA0	Wait ACK (1775 KA buffer full).
0xB0	Remote node problem due to download.
0xC0	Wait ACK (1775 KA buffer full).
0xD0	not used
0xE0	not used
0xF0	Error code in the EXT STS byte. See the error code table on the next page.

PLC Errors for Allen-Bradley DF1 Protocol, Local STS Errors (0-3 bits)

Panel Error Code P499 Hex Value	Description
0x0	Success; no error.
0x1	DST node is out of buffer space.
0x2	Cannot guarantee delivery; link layer. (The remote node specified does not ACK command.)
0x3	Duplicate token holder detected.
0x4	Local port is disconnected.
0x5	Application layer timed out waiting for response.
0x6	Duplicate node detected.
0x7	Station is offline.
0x8	Hardware fault.

(PLC generated error codes for the Allen-Bradley DF1 Protocol continued on the next page.)

Allen-Bradley DF1 Protocol – PLC Error Code Tables (cont'd)

A

PLC Errors for Allen-Bradley DF1 Protocol, EXT STS Command Code for F0 Command	
Panel Error Code P499 Hex Value	Description
0x0	not used
0x1	A field has an illegal value.
0x2	Fewer levels specified in address than minimum for any address.
0x3	More levels specified in address than system supports.
0x4	Symbol not found.
0x5	Symbol is of improper format.
0x6	Address does not point to something usable.
0x7	File is wrong size.
0x8	Cannot complete request; situation has changed since start of the command.
0x9	Data or file size is too large.
0xA	Transaction size plus word address is too large.
0xB	Access denied; improper privilege.
0xC	Condition cannot be generated; resource is not available.
0xD	Condition already exists; resource is readily available.
0xE	Command cannot be executed.
0xF	Histogram overflow.
0x10	No access.
0x11	Illegal data type.
0x12	Invalid parameter or invalid data.
0x13	Address reference exists to deleted area.
0x14	Command execution failure for unknown reason; possible PLC 3 histogram overflow.
0x15	Data conversion error.
0x16	Scanner not able to communicate with 1771 rack adapter.
0x17	Type mismatch.
0x18	1771 module response was not valid.
0x19	Duplicated label.
0x22	Remote rack fault.
0x23	Timeout.
0x24	Unknown error.
0x1A	File is open; another node owns it.
0x1B	Another node is the program owner.
0x1C	Reserved
0x1D	Reserved
0x1E	Data table element protection violation.
0x1F	Temporary internal problem.

Allen-Bradley DH485 Protocol – PLC Error Code Tables

The following PLC error code tables cover possible errors that are detected by the panel from Allen-Bradley PLCs using the DH485 protocol. This includes all MicroLogix and SLC500 PLCs, and any communication connection using an Allen-Bradley AIC device using the DH485 protocol.



Note: The following errors can be generated from the designated PLC, are monitored by the **C-more** Micro-Graphic panel, and displayed on the panel's screen as a hexadecimal value in panel error code P499, if active. Please refer to the PLC users manual for additional information.

PLC Errors for Allen-Bradley DH485 Protocol, Local STS Errors (0-3 bits)

Panel Error Code P499 Hex Value	Description
0x0	Success; no error.
0x1	DST node is out of buffer space.
0x2	Cannot guarantee delivery; link layer. (The remote node specified does not ACK command.)
0x3	Duplicate token holder detected.
0x4	Local port is disconnected.
0x5	Application layer timed out waiting for response.
0x6	Duplicate node detected.
0x7	Station is offline.
0x8	Hardware fault.

PLC Errors for Allen-Bradley DH485 Protocol, Remote STS Errors (4-7 bits)

Panel Error Code P499 Hex Value	Description
0x0	Success; no error.
0x10	Illegal command or format.
0x20	Host has a problem and will not communicate.
0x30	Remote node host is missing, disconnected, or shut down.
0x40	Host could not complete function due to hardware fault.
0x50	Addressing problem or memory protect rungs.
0x60	Function not allowed due to command protection selection.
0x70	Processor is in Program Mode.
0x80	Compatibility mode file missing or communication zone problem.
0x90	Remote node cannot buffer command.
0xA0	Wait ACK (1775 KA buffer full).
0xB0	Remote node problem due to download.
0xC0	Wait ACK (1775 KA buffer full).
0xD0	not used
0xE0	not used
0xF0	Error code in the EXT STS byte. See the error code table on the next page.

(PLC generated error codes for the Allen-Bradley DH485 protocol continued on the next page.)

Allen-Bradley DH485 Protocol – PLC Error Code Tables (cont'd)

A

PLC Errors for Allen-Bradley DH485 Protocol, EXT STS Command Code for F0 Command	
Panel Error Code P499 Hex Value	Description
0x7	Insufficient memory module size (0000h is returned).
0xB	Access denied; privilege violation.
0xC	Resource not available or cannot do.
0xE	CMD cannot be executed.
0x12	Invalid parameter.
0x14	Failure during processing.
0x19	Duplicate label.
0x1A	File open by another node + owner's local node address, 1 byte.
0x1B	Program owned by another node + program owner's local node address, 1 byte.

GE Error Code P499 Explanation

The P499 error code is used to show any errors that are generated by the connected PLC. The P499 error message includes a four digit hexadecimal value displayed at the end of the message. This value can be looked up in the specific PLC's error tables to determine the cause of the error. The possible PLC generated error codes for the GE 90-30, 90-70, Micro 90 and VersaMax Micro SNPX communication protocols breakdown into a four digit hexadecimal value.

GE Error Code P499 Message Example:

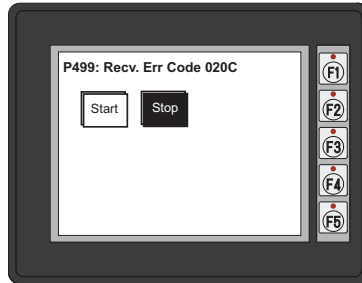

GE SNPX Protocol – PLC Error Code Tables

The following table lists the errors that can be generated by the GE 90-30, 90-70 and VersaMax PLC when using the SNPX protocol.



Note: The following errors can be generated from the designated PLC, are monitored by the **C-more** Micro-Graphic panel, and displayed on the panel's screen as a hexadecimal value in panel error code P499, if active. Please refer to the PLC users manual for additional information.

PLC Errors for GE SNPX Protocol (Major)	
Panel Error Code P499 Hex Value	Description
No error	Successful completion. (This is the expected completion value in the COMMREQ Status Word.)
0x0002	Insufficient Privilege. For Series 90-70 PLC, the minor error code contains the privilege level required for the service request.
0x0004	Protocol Sequence Error. The CPU has received a message that is out of order.
0x0005	Service Request Error, the minor error code contains the specific error code.
0x0006	Illegal Mailbox Type. Service request mailbox type is either undefined or unexpected.
0x0007	The PLC CPU's Service Request Queue is full. The master should retry later. It is recommended that the master wait a minimum of 10 msec before sending another service request.
0x000A	SNP DOS Driver Error. The minor error code contains the specific error code.
0x000B	Illegal Service Request. The requested service is either not defined or not supported. (This value is returned in lieu of the actual 01h value passed in the SNP error message, to avoid confusion with the normal successful COMMREQ completion.)
0x000C	Local SNP/SNP-X Error. An error occurred within the SNP task in the CMM module in this PLC. This error may occur in either an SNP master or an SNP slave. The minor error code contains the specific error code.
0x000D	Remote SNP Error. An error occurred within the SNP slave task in the CMM module in the remote PLC. The minor error code contains the specific error code.
0x000E	Autodial Error. An error occurred while attempting to send a command string to an attached external modem. The minor error code contains the specific error code.
0x000F	SNP-X slave error. An error occurred within the SNPX task in the remote slave device. The minor error code contains the specific error code.
0x0013	Port configurator error.
0x0050	Problem with sending mail to the slave Service Request task. (Series 90-70 PLC CPUs only)
0x0051	Problem with getting mail from the slave Service Request task. (Series 90-70 PLC CPUs only)
0x0055	Slave SNP task timed out before receiving an SRP response. (Series 90-70 PLC CPUs only)
0x0056	Slave SNP task could not find the requested datagram connection. (Series 90-70 PLC CPUs only)
0x0057	Slave SNP task encountered an error in trying to write the datagram. (Series 90-70 PLC CPUs only)
0x0058	Slave SNP task encountered an error in trying to update the datagram. (Series 90-70 PLC CPUs only)

(PLC generated error codes for the GE 90-30, 90-70 and VersaMax SNPX protocol continued on the next page.)

GE SNPX Protocol – PLC Error Code Tables (cont'd)

PLC Errors for GE SNPX Protocol (Minor-Major) (cont'd)	
Panel Error Code P499 Hex Value	Description
PLC Error 0x010C	WAIT-type COMMREQ is not permitted; must use NOW AIT-type.
PLC Error 0x010E	Not used
PLC Error 0x010F	The service request code in an X-Request message is unsupported or invalid at this time. This error may occur if an SNP-X communication session has not been successfully established at the slave device.
PLC Error 0x020C	COMMREQ command is not supported.
PLC Error 0x020E	The modem command string length exceeds 250 characters.
PLC Error 0x020F	Insufficient privilege level in the slave PLC CPU for the requested SNP-X service. Password protection at PLC CPU may be preventing the requested service.
PLC Error 0x0213	Unsupported COMMREQ. These errors are only generated when there is no protocol currently being run on a port, and the port receives a COMMREQ. (The port may be disabled or an error has occurred in processing a new configuration).
PLC Error 0x030C	SNP communication is not active. Must initiate a new SNP communication by sending an Attach or Long Attach COMMREQ.
PLC Error 0x030E	COMMREQ Data Block Length is too small. Output command string data is missing or incomplete.
PLC Error 0x030F	Invalid slave memory type in X-Request message.
PLC Error 0x0313	Invalid COMMREQ length.
PLC Error 0x040C	SNP slave did not respond to Attach message from master.
PLC Error 0x040E	Serial output timeout. The CMM module was unable to transmit the modem autodial output from the serial port. (May be due to missing CTS signal when the CMM is configured to use hardware flow control.)
PLC Error 0x040F	Invalid slave memory address or range in X-Request message.
PLC Error 0x0413	Invalid COMMREQ status word location.
PLC Error 0x050C	Unable to write SNP Status Word to local PLC memory; may be due to invalid Status Word memory type or address.
PLC Error 0x050E	Response was not received from modem. Check modem and cable.
PLC Error 0x050F	Invalid data length in X-Request message. Data length must be non-zero, and may not exceed decimal 1000 bytes.
PLC Error 0x0513	Invalid COMMREQ data.
PLC Error 0x060C	Master device memory type is not valid in this PLC.
PLC Error 0x060E	Modem responded with BUSY. Modem is unable to complete the requested connection. The remote modem is already in use; retry the connection request at a later time.
PLC Error 0x060F	X-Buffer data length does not match the service request in X-Request message. The X-Buffer message length is obtained from the Next Message Length field in the X-Request message; the length of the data within the buffer message is always the message length.
PLC Error 0x070C	Master device memory address or length is zero.
PLC Error 0x070E	Modem responded with NO CARRIER. Modem is unable to complete the requested connection. Check the local and remote modems and the telephone line.
PLC Error 0x070F	Queue Full indication from Service Request Processor in slave PLC CPU. The slave is temporarily unable to complete the service request. The master should try again later. It is recommended that the master wait at least 10 msec before repeating the X-Request.

(PLC generated error codes for the GE 90-30, 90-70 and VersaMax SNPX protocol continued on the next page.)

GE SNPX Protocol – PLC Error Code Tables (cont'd)

A

PLC Errors for GE SNPX Protocol (Minor-Major) (cont'd)	
Panel Error Code P499 Hex Value	Description
0x080C	Unable to read or write master device memory locations specified in COMMREQ. Usually caused by invalid memory address for this PLC. SNP message exchange may have taken place.
0x080E	Modem responded with NO DIALTONE. Modem is unable to complete the requested connection. Check the modem connections and the telephone line.
0x080F	Service Request Processor response exceeds 1000 bytes; the SNP-X slave device cannot return the data in an X-Response message. (This error applies to CMM module only.)
0x090C	Master device memory data length exceeds maximum data size of CMM module (2048 bytes). Must use a smaller data length. Use multiple COMMREQs if total data length exceeds this maximum value.
0x090E	Modem responded with ERROR. Modem is unable to complete the requested command. Check the modem command string and modem.
0x0A0C	Slave device memory type is missing or not valid.
0x0A0E	Modem responded with RING, indicating that the modem is being called by another modem. Modem is unable to complete the requested command. Retry the modem command at a later time.
0x0B0C	Slave device memory address is missing or zero.
0x0B0E	An unknown response was received from the modem. Modem is unable to complete the requested command. Check the modem command string and modem. The modem response is expected to be either CONNECT or OK.
0x0C0C	COMMREQ Data Block Length is too small. (When expected COMMREQ length is 6 words or less. An improper length may cause other minor error codes 6-11.)
0x0D0C	Invalid Diagnostic Status Word (DSW) starting word or length.
0x0E0C	Invalid maximum SNP message data size. Must be an even value from 42 to 2048.
0x0F0C	Invalid Privilege Level. Must be 0 through 4 or -1.
0x100C	Invalid Fault Table selector. Must be 1 for I/O Fault Table, or 2 for PLC Fault Table.
0x100F	Unexpected Service Request Processor error. (This error applies to CMM module only; the unexpected SRP error code is saved in the Diagnostic Status Words in the CMM module.)
0x110C	Invalid Fault Table starting index. Must be 1-32 for I/O Fault Table, or 1-16 for PLC.
0x120C	Invalid fault count. Must be 1-32 for I/O Fault Table, or 1-16 for PLC Fault Table.
0x130C	Invalid Set PLC Date/Time mode. Must be 1-4.
0x140C	Invalid Set PLC Date/Time date, time, or day-of-week value.
0x150C	Unable to retrieve master device PLC time/date from PLC CPU.
0x150F	Requested service is not permitted in a Broadcast request. The master must direct the X-Request message to a specific SNP-X slave device.
0x160C	Invalid slave PLC type. Must be 0 for Series 90-70, or 1 for Series 90-30 or Series 90-20.
0x170C	Invalid datagram type. Must be 01h for normal datagram, or 81h (129) for permanent datagram.
0x180C	Missing or too many datagram point formats. Must be 1-32.
0x190C	Invalid datagram point format data.

(PLC generated error codes for the GE 90-30, 90-70 and VersaMax SNPX protocol continued on the next page.)

GE SNPX Protocol – PLC Error Code Tables (cont'd)

PLC Errors for GE SNPX Protocol (Minor-Major) (cont'd)	
Panel Error Code P499 Hex Value	Description
0x1A0C	Datagram area size is too small to include data for all specified point formats.
0x1B0C	Invalid number of Control Program Names. Must be 1-8.
0x1C0C	SNP-X Request exceeds maximum data size (1000 bytes). Must use a smaller data length. Use multiple COMMREQs if necessary.
0x1D0C	Invalid SNP-X communication session type. Must be 0 for a single slave device, or 1 for multiple slave devices.
0x1E0C	Illegal destination SNP ID specified for SNP-X slave. Must be 0-7 ASCII characters, plus a terminating null character (00h). The Null SNP ID (eight bytes of 00h) may be used to specify any single device. The Broadcast SNP ID (eight bytes of FFh) may be used to specify all slave devices on the serial link.
0x1F0C	Destination SNP ID does not match SNP-X session type. The Broadcast SNP ID is not permitted in a single-slave SNP-X session. The Null SNP ID is not permitted in a multiple-slave SNP-X session.
0x200C	Inactivity timeout (T3'). The SNP slave has not received any new SNP messages within the configured T3' time interval.
0x200F	Invalid Message Type field in a received X-Request message. The message type of an X-Request message must be 58h = 'X'.
0x210C	A Parity error has occurred on an Attach, Attach Response, or Update Real-time Datagram message. Communications have not been established.
0x210F	Invalid Next Message Type or Next Message Length field in a received X Request message. If this request does not use a buffer (0-2 bytes of data), the Next Message Type must be zero. If this request will be followed with a buffer message (more than 2 byte.)), the Next Message Type must be 54h = 'T', and the Next Message Length must specify the length of the X-Buffer message. Valid X-Buffer message lengths are 9-1008 bytes (data length plus 8 bytes).
0x220C	A BCC (Block Check Code) error has occurred on an Attach, Attach Response, or Update Realtime Datagram message. Communications have not been established.
0x220F	Invalid Message Type field in a received X-Buffer message. The message type of an X-Buffer message must be 54h = 'T'.
0x230C	A Framing or Overrun serial error has occurred on an Attach, Attach Response, or Update Realtime Datagram message. Communications have not been established.
0x230F	Invalid Next Message Type field in a received X-Buffer message. Since an X-Buffer message is never followed by another message, the Next Message Type must always be zero.
0x240C	An invalid SNP message type was received when an Attach, Attach Response, or Update Realtime Datagram message was required. Communications have not been established.
0x250C	An invalid next message length value was specified in an Attach, Attach Response, or Update Realtime Datagram message. Communications have not been established.
0x260C	An unexpected SNP message type was received when an Attach, Attach Response, or Update Realtime Datagram was required. Communications have not been established.
0x270C	Another Break was received while SNP slave was waiting for an Attach or Update Realtime Datagram message.
0x280C	An SNP message has been sent and retried the maximum number of times. A maximum of two retries are permitted. A retry is caused by a NAK from from the remote SNP device.
0x290C	A received SNP message has been NAKed the maximum number of two times. The NAKed message may be retransmitted a maximum of two times.

(PLC generated error codes for the GE 90-30, 90-70 and VersaMax SNPX protocol continued on the next page.)

GE SNPX Protocol – PLC Error Code Tables (cont'd)

A

PLC Errors for GE SNPX Protocol (Minor-Major) (cont'd)	
Panel Error Code P499 Hex Value	Description
0x2A0C	An unknown message was received when an acknowledge (ACK or NAK) was required.
0x2B0C	Sequence Error. An unexpected SNP message type was received.
0x2C0C	Received SNP message contains bad next message length value.
0x2D0C	Acknowledge timeout. An acknowledge (ACK or NAK) was not received within the configured T2 time interval. A slave device may generate this error if the master device has aborted after maximum response NAKs and does not NAK the next response retry.
0x2E0C	Response timeout. The SNP Master did not receive an SNP Response message within the configured T5' time interval.
0x2F0C	Buffer message timeout. An expected Text Buffer or Connection Data message was not received within the configured T5'' time interval.
0x300C	Serial output timeout. The CMM module was unable to transmit a Break, an SNP message, or SNP acknowledge (ACK or NAK) from the serial port. (May be due to missing CTS signal when the CMM module is configured to use hardware flow control.)
0x310C	SNP slave did not receive a response from the Service Request Processor in the PLC CPU.
0x320C	COMMREQ timeout. The COMMREQ did not complete within the configured time interval.
0x330C	An SNP Request or Response was aborted prior to completion due to reception of a Break.
0x340C	PLC backplane communications error
0x350C	Invalid Piggyback Status data memory type or address. Communications have not been established.
0x360C	Invalid SNP Slave SNP ID. Must be a 0-7 ASCII characters, plus a terminating null character (00h). The Null SNP ID (eight bytes of 00h) may be used to specify any single slave device.
0x370C	The SNP master has received a response message containing an unexpected data length. Usually indicates a problem with the remote SNP slave device. May occur when Series 90-70 commands (Task Memory or Program Block Memory Read/Write) are issued to a Series 90-30 slave device.
0x380C	Response code in received SNP-X response message does not match expected value. (Response code must equal the request code +80h.)
0x390C	SNP-X Response message exceeds maximum data size (decimal 1000 bytes). Data in the Response is ignored.
0x400C	A parity error has occurred on an X-Attach Response message when establishing a new SNP-X communication session. Communications have not been established.
0x400D	The requested service is not supported by the SNP slave.
0x400F	Serial output timeout. The slave was unable to transmit an SNP-X message from the serial port. (May be due to missing CTS signal when the CMM module is configured to use hardware flow control.)

(PLC generated error codes for the GE Fanuc 90-30, 90-70 and VersaMax SNPX protocol continued on the next page.)

GE SNPX Protocol – PLC Error Code Tables (cont'd)

PLC Errors for GE SNPX Protocol (Minor-Major) (cont'd)	
Panel Error Code P499 Hex Value	Description
0x410C	A framing or overrun error has occurred on an X-Attach Response message when establishing a new SNP-X communication session. Communications have not been established.
0x410D	SNP slave on CMM module requires PLC CPU privilege level 2 to operate. The SNP slave has rejected a request to change to a higher or lower privilege level.
0x410F	An SNP-X request was aborted prior to completion due to reception of a Break.
0x420C	A BCC (Block Check Code) error has occurred on an X-Attach Response message when establishing a new SNP-X communication session. Communications have not been established.
0x420D	SNP Request or Response message exceeds maximum data length of the CMM module. (Total data length for Mailbox and all following Buffer messages is 2048 bytes.) The master must use a smaller data length. Use multiple requests if total data length exceeds the maximum value.
0x420F	An X-Buffer message was received containing greater than 1000 bytes of data. The data is ignored.
0x430C	An invalid message type was received when an X-Attach Response was required when establishing a new SNP-X communication session. Communications have not been established.
0x430D	Improper Write Datagram message format. Series 90-70 slave devices use a different format for this message than Series 90-30 or Series 90-20 slave devices. The master must use the proper message format for this SNP slave device. (The SNP master in the CMM module sends this message as part of the Establish Datagram COMMREQ command. The datagram has been partially established, but is not usable; the datagram should be cancelled by using the Datagram ID returned by the COMMREQ.)
0x430F	The SNP-X slave did not receive a response from the Service Request Processor in the PLC CPU.
0x440C	An invalid next message type value was detected in an X-Attach Response message when establishing a new SNP-X communication session. Communications have not been established.
0x440D	A datagram error occurred in a Series 90-70 slave device (dual-port error).
0x440F	PLC backplane communications error.
0x450C	An invalid response code was detected in an X-Attach Response message when establishing a new SNP-X communication session. Communications have not been established.
0x460C	An expected X-Attach Response message was not received within the response timeout interval when establishing a new SNP-X communication session. The master has retried the X-Attach message twice without receiving a response. Communications have not been established.
0x500C	A parity error has occurred on an X-Attach Response message when re-establishing an existing SNP-X communication session. Communications have not been established.
0x500F	A parity error has occurred in a received X-Attach message.
0x510C	A framing or overrun error has occurred on an X-Attach Response message when re-establishing an existing SNP-X communication session. Communications have not been established.
0x510F	A framing or overrun error has occurred in a received X-Attach message.
0x520C	A BCC (Block Check Code) error has occurred on an X-Attach Response message when re-establishing an existing SNP-X communication session. Communications have not been established.
0x520F	A BCC (Block Check Code) error has occurred in a received X-Attach message.

(PLC generated error codes for the GE Fanuc 90-30, 90-70 and VersaMax SNPX protocol continued on the next page.)

GE SNPX Protocol – PLC Error Code Tables (cont'd)

A

PLC Errors for GE SNPX Protocol (Minor-Major) (cont'd)	
Panel Error Code P499 Hex Value	Description
0x530C	An invalid message type was received when an X-Attach Response was required when re-establishing an existing SNP-X communication session. Communications have not been established.
0x530F	An invalid Message Type was received when an X-Attach message was required. (For an X-Attach message, the message type must be 58h = 'T'.)
0x540C	An invalid Next Message Type value was detected in an X-Attach Response message when re-establishing an existing SNP-X communication session. Communications have not been established.
0x540F	An invalid Next Message Type value was detected in a received X-Attach message. (For an X-Attach message, the Next Message Length must be zero.)
0x550C	An invalid response code was detected in an X-Attach Response message when re-establishing an existing SNP-X communication session. Communications have not been established.
0x550F	An invalid request code was detected in a received X-Attach message.
0x560C	An expected X-Attach Response message was not received within the response timeout interval when re-establishing an existing SNP-X communication session. The master has retried the X-Attach message twice without receiving a response. Communications have not been established.
0x600C	A parity error has occurred on an X-Response message.
0x600F	A parity error has occurred in a received X-Request message.
0x610C	A framing or overrun error has occurred on an X-Response message.
0x610F	A framing or overrun error has occurred in a received X-Request message.
0x620C	A BCC (Block Check Code) error has occurred on an X-Response message.
0x620F	A BCC (Block Check Code) error has occurred in a received X-Request message.
0x630C	An invalid message type was received when an X-Response message was required.
0x640C	An invalid next message type value was detected in an X-Response message.
0x650C	An invalid response code was detected in an X-Response message.
0x660C	An expected X-Response message was not received within the response time.
0x700C	A parity error has occurred on an Intermediate Response message.
0x700F	A parity error has occurred in a received X-Buffer message.
0x710C	A framing or overrun error has occurred on an Intermediate Response message.
0x710F	A framing or overrun error has occurred in a received X-Buffer message.
0x720C	A BCC (Block Check Code) error has occurred on an Intermediate Response message.
0x720F	A BCC (Block Check Code) error has occurred in a received X-Buffer message.
0x730C	An invalid message type was received when an Intermediate Response message was required.
0x730F	An expected X-Buffer message was not received.
0x740C	An invalid next message type value was detected in an Intermediate Response message.
0x750C	An invalid response code was detected in an Intermediate Response message.
0x760C	An expected Intermediate Response message was not received within the response timeout interval.

(PLC generated error codes for the GE Fanuc 90-30, 90-70 and VersaMax SNPX protocol continued on the next page.)

GE SNPX Protocol – PLC Error Code Tables (cont'd)

PLC Errors for GE SNPX Protocol (Minor-Major) (cont'd)	
Panel Error Code P499 Hex Value	Description
0x8DOA	Bad DOS Version. Must have DOS 2.0, or later, to support the SNP DOS Driver.
0x8EOA	PC Serial port configured for SNP Master driver is not open; no communication can take place.
0x8FOA	Out-of-Sequence SNP message. SNP message type received was not the type expected.
0x900A	Bad SNP BCC encountered. Transmission was aborted after maximum retries due to a bad Block Check Code.
0x910A	Bad SNP communication. Transmission was aborted after maximum retries due to serial errors (that is, parity, overrun, or framing errors).
0x920A	No SNP communication. Either communication has been lost or a communication session has not been established.
0xC105	Invalid block state transition.
0xC205	The OEM key is NULL (inactive).
0xC305	Text length does not match traffic type.
0xC405	Verify with FA Card or EEPROM failed.
0xC505	No task-level Rack/Slot configuration to read or delete.
0xC605	Control Program (CP) tasks exist but requestor not logged into main CP.
0xC705	Passwords are set to inactive and cannot be enabled or disabled.
0xC805	Password(s) already enabled and can not be forced inactive.
0xC905	Login using non-zero buffer size required for block commands.
0xCA05	Device is write-protected.
0xCB05	A comm or write verify error occurred during save or restore.
0xCC05	Data stored on device has been corrupted and is no longer reliable.
0xCD05	Attempt was made to read a device but no data has been stored on it.
0xCE05	Specified device has insufficient memory to handle request.
0xCF05	Specified device is not available in the system (not present).
0xD005	One or more PLC modules configured have unsupported revision.
0xD105	Packet size or total program size does not match input.
0xD205	Invalid write mode parameter.
0xD305	User Program Module (UPM) read or write exceeded block end.
0xD405	Mismatch of configuration checksum.
0xD505	Invalid block name specified in datagram.
0xD605	Total datagram connection memory exceeded.
0xD705	Invalid datagram type specified.
0xD805	Point length not allowed.
0xD905	Transfer type invalid for this Memory Type selector.
0xDA05	Null pointer to data in Memory Type selector.
0xDB05	Invalid Memory Type selector in datagram.
0xDC05	Unable to find connection address.
0xDD05	Unable to locate given datagram connection ID.
0xDE05	Size of datagram connection invalid.
0xDF05	Invalid datagram connection address.

(PLC generated error codes for the GE Fanuc 90-30, 90-70 and VersaMax SNPX protocol continued on the next page.)

GE SNPX Protocol – PLC Error Code Tables (cont'd)

A

PLC Errors for GE SNPX Protocol (Minor-Major) (cont'd)	
Panel Error Code P499 Hex Value	Description
0xE005	Service in process cannot login.
0xE105	No I/O configuration to read or delete.
0xE205	IOS could not delete configuration, or bad type.
0xE305	CPU revision number does not match.
0xE405	Memory Type for this selector does not exist.
0xE505	DOS file area not formatted.
0xE605	CPU model number does not match.
0xE705	Configuration is not valid.
0xE805	No user memory is available to allocate.
0xE905	Memory Type selector not valid in context.
0xEA05	Not logged in to process service request.
0xEB05	Task unable to be deleted.
0xEC05	Task unable to be created.
0xED05	VME bus error encountered.
0xEE05	Could not return block sizes.
0xEF05	Programmer is already attached.
0xF005	Request only valid in stop mode.
0xF105	Request only valid from programmer.
0xF205	Invalid program cannot log in.
0xF305	I/O configuration mismatch.
0xF405	Invalid input parameter in request.
0xF505	Invalid password.
0xF605	Invalid sweep state to set.
0xF705	Required to log in to a task for service.
0xF805	Invalid Task Name referenced.
0xF905	Task address out of range.
0xFA05	Cannot replace I/O module.
0xFB05	Cannot clear I/O configuration.
0xFC05	I/O configuration is invalid.
0xFD05	Unable to perform auto configuration.
0xFE05	No privilege for attempted operation.
0xFF05	Service Request Error has been aborted.

Mitsubishi FX Protocol – PLC Error Codes

Only errors as listed in the *C-more* Micro-Graphic Panel Error Code Table shown on page A-3 can occur when using the Mitsubishi FX protocol, there are no PLC generated errors.

Mitsubishi Q / QnA Series – PLC Error Codes

The following table lists the errors that can be generated by the Mitsubishi Q / QnA Series PLC when using the Q / QnA protocol.



Note: The following errors can be generated from the designated PLC, are monitored by the *C-more* Micro-Graphic panel, and displayed on the panel's screen as a hexadecimal value in panel error code P499, if active. Please refer to the PLC users manual for additional information.

PLC Error Codes for Mitsubishi Q / QnA and Q Series	
Panel Error Code P499 Hex Value	Description
0x4000	Serial communications checksum error. Check cable and grounding.
0x4001	Unsupported request sent to PLC.
0x4002	Unsupported request sent to PLC.
0x4003	Global request sent to PLC that cannot be executed.
0x4004	System protect switch is on and request was sent that cannot be executed. Also PLC, may still be booting up.
0x4005	Packet sent is too large according to size request in header.
0x4006	Serial communications could not be initialized.
0x4008	CPU busy or buffer full.
0x4010	Request cannot be serviced while CPU is running. CPU must be stopped.
0x4013	Request cannot be serviced while CPU is running. CPU must be stopped.
0x4021	Drive memory does not exist.
0x4022	File (ZR memory) does not exist.
0x4023	File (ZR memory) name and File (ZR memory) number do not match.
0x4024	File (ZR memory) inaccessible by user.
0x4025	File (ZR memory) is locked by another device.
0x4026	File (ZR memory) password required.
0x4027	Specified range is out of File (ZR memory) range.
0x4028	File (ZR memory) already exist.
0x4029	Specified File (ZR memory) capacity cannot be retrieved.
0x402A	Specified File (ZR memory) is abnormal.
0x402B	The requested data cannot be executed in the specified drive memory.
0x402C	The requested operation cannot be executed presently.
0x4030	The specified data type does not exist. Check the CPUs allowable data types.
0x4031	The specified address is out of range. The data type requested may need to be expanded in GX developer. The CPU may not allow this data type.
0x4032	Address qualification is incorrect.
0x4033	Cannot write to system area.
0x4034	Request cannot be executed because completion address for an instruction cannot be turned on.

(PLC generated error codes for the Mitsubishi Q / QnA protocol continued on the next page.)

Mitsubishi Q / QnA Series – PLC Error Codes (cont'd)

A

PLC Error Codes for Mitsubishi Q / QnA and Q Series	
Panel Error Code P499 Hex Value	Description
0x4040	Module doesn't support request.
0x4041	Request is out of module's range.
0x4042	Module cannot be accessed.
0x4043	Address for specified module is incorrect.
0x4044	Hardware problem exist for specified module.
0x4050	Request cannot be executed because memory card protect switch is on.
0x4051	Specified memory cannot be accessed.
0x4052	Specified memory attribute is read only and cannot be written to.
0x4053	Error occurred when writing to specified memory location.
0x4080	Request data error. Check cabling and electrical noise.
0x4082	Specified request is already being executed.
0x408B	The remote request cannot be performed.
0x40A0	A block number out of range was specified.
0x40A1	The number of blocks requested exceeds the range of the PLC.
0x40A2	A step number was specified out of range.
0x40A3	Step range limit exceeded.
0x40A4	Specified sequence step number is out of range.
0x40A5	Specified SFC device is out of range.
0x40A6	Block specification and step specification are incorrect.
0x4100	CPU module hardware fault.
0x4101	Serial communication connection incorrect.
0x4105	CPU module internal memory fault. Bad CPU.
0x4106	CPU is in initialization. Wait until CPU is booted up.
0x4107	Specified function not supported by this CPU. Check memory types for that CPU.
0x4110	Specified function not supported because CPU is in Stop. Put CPU in Run.
0x4111	System is not up yet. Wait until system is up before performing request.
0x4A01	The network number specified does not exist. Routing not supported in C-more.
0x4A02	Station number specified does not exist. Routing not supported in C-more.

Omron Error Code P499 Explanation

The P499 error code is used to show any errors that are generated by the connected PLC. The P499 error message includes a four digit hexadecimal value displayed at the end of the message. This value can be looked up in the specific PLC's error tables to determine the cause of the error. The possible PLC generated error codes for the Omron Host Link communication protocols breakdown into a four digit hexadecimal value.

Omron Error Code P499 Message Example:

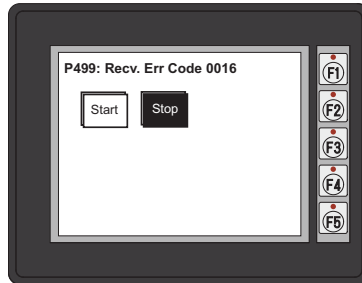

Omron Host Link Protocol – PLC Error Code Table

The following table lists the errors that can be generated by the Omron PLC when using the Host Link protocol.



Note: The following errors can be generated from the designated PLC, are monitored by the **C-more Micro-Graphic** panel, and displayed on the panel's screen as a hexadecimal value in panel error code P499, if active. Please refer to the PLC manufacturer's documentation for additional information.

PLC Error Codes for Omron Host Link	
Panel Error Code P499 Hex Value	Description
0x00	Normal Completion.
0x01	Not executable in RUN mode.
0x02	Not executable in MONITOR mode.
0x03	Not executable with PROM mounted.
0x04	Address over (data overflow).
0x0B	Not executable in PROGRAM mode.
0x0C	Not executable in DEBUG mode.
0x0D	Not executable in LOCAL mode.
0x10	Parity error.
0x11	Framing error.
0x12	Overrun.
0x13	FCS error.
0x14	Format error (parameter length error).
0x15	Entry number data error (parameter error, data code error, data length error).
0x16	Instruction not found.
0x18	Frame length error.
0x19	Not executable (due to Un-executable error clear, non-registration of I/O table, etc.).
0x20	I/O table generation impossible (unrecognized remote I/O unit, channel over, duplication of optical transmitting I/O unit).
0xA0	Abort due to parity error in transmit data under process.
0xA1	Abort due to framing error in transmit data under process.
0xA2	Abort due to overrun in transmit data under process.
0xA3	Abort due to FCS error in transmit data under process.
0xA4	Abort due to format error in transmit data under process.
0xA5	Abort due to frame length error in transmit data under process.
0xA8	Abort due to entry number data error in transmit data under process.
0xB0	Un-executable due to program area capacity other than 16k bytes.

Omron FINS Protocol – PLC Error Code Table

The following table lists the errors that can be generated by the Omron PLC when using the FINS protocol.



Note: The following errors can be generated from the designated PLC, are monitored by the **C-more Micro-Graphic** panel, and displayed on the panel's screen as a hexadecimal value in panel error code P499, if active. Please refer to the PLC manufacturer's documentation for additional information.

PLC Error Codes for Omron FINS	
Panel Error Code P499 Hex Value	Description
0x0000	Normal Completion.
0x0001	Service Canceled.
0x0101	Local Error: Local node not in network.
0x0102	Local Error: Token Timeout.
0x0103	Local Error: Retries Failed.
0x0104	Local Error: Too many send frames.
0x0105	Local Error: Node address range error.
0x0106	Local Error: Node Address Duplication.
0x0201	Destination Node Error: Destination Node not in network.
0x0202	Destination Node Error: Unit Missing.
0x0203	Destination Node Error: Third Node missing.
0x0204	Destination Node Error: Destination Node busy.
0x0205	Destination Node Error: Response Timeout.
0x0301	Controller Error: Communications Controller Error.
0x0302	Controller Error: CPU Unit Error.
0x0303	Controller Error: Controller Error.
0x0304	Controller Error: Unit number Error.
0x0401	Service Unsupported: Undefined Command.
0x0402	Service Unsupported: Not supported by Model/Version.
0x0501	Routing Table Error: Destination address setting error.
0x0502	Routing Table Error: No routing tables.
0x0503	Routing Table Error: Routing table error.
0x0504	Routing Table Error: Too many delays.
0x1001	Command Format Error: Command too long.
0x1002	Command Format Error: Command too short.
0x1003	Command Format Error: Elements/Data don't match.
0x1004	Command Format Error: Command format error.
0x1005	Command Format Error: Header Error.
0x1101	Parameter Error: Area classification missing.
0x1102	Parameter Error: Access Size Error.
0x1103	Parameter Error: Address range error.

(PLC generated error codes for the Omron FINS protocol continued on the next page.)

Omron FINS Protocol – PLC Error Code Table (cont'd)

A

PLC Error Codes for Omron FINS	
Panel Error Code P499 Hex Value	Description
0x1104	Parameter Error: Address range exceeded.
0x1106	Parameter Error: Program Missing.
0x1109	Parameter Error: Relational Error.
0x110A	Parameter Error: Duplicate Data Access.
0x110B	Parameter Error: Response too long.
0x110C	Parameter Error: Parameter Error.
0x2002	Read Not Possible: Protected.
0x2003	Read Not Possible: Table missing.
0x2004	Read Not Possible: Data missing.
0x2005	Read Not Possible: Program missing.
0x2006	Read Not Possible: File missing.
0x2007	Read Not Possible: Data mismatch.
0x2101	Write Not Possible: Read Only.
0x2102	Write Not Possible: Protected - cannot write data link table.
0x2103	Write Not Possible: Cannot register.
0x2105	Write Not Possible: Program missing.
0x2106	Write Not Possible: File missing.
0x2107	Write Not Possible: File name already exists.
0x2108	Write Not Possible: Cannot change.
0x2201	Not executable in current mode: Not possible during execution.
0x2202	Not executable in current mode: Not possible while running.
0x2203	Not executable in current mode: Wrong PLC mode (Program).
0x2204	Not executable in current mode: Wrong PLC mode (Debug).
0x2205	Not executable in current mode: Wrong PLC mode (Monitor).
0x2206	Not executable in current mode: Wrong PLC mode (Run).
0x2207	Not executable in current mode: Specified node not polling node.
0x2208	Not executable in current mode: Step cannot be executed.
0x2301	No such device: File device missing.
0x2302	No such device: Missing memory.
0x2303	No such device: Clock missing.
0x2401	Cannot Start/Stop: Table missing.
0x2502	Unit Error: Memory Error.
0x2503	Unit Error: I/O setting Error.
0x2504	Unit Error: Too many I/O points.
0x2505	Unit Error: CPU bus error.
0x2506	Unit Error: I/O Duplication.

(PLC generated error codes for the Omron FINS protocol continued on the next page.)

Omron FINS Protocol – PLC Error Code Table (cont'd)

PLC Error Codes for Omron FINS	
Panel Error Code P499 Hex Value	Description
0x2507	Unit Error: I/O bus error.
0x2509	Unit Error: SYSMAC BUS/2 error.
0x250A	Unit Error: CPU Bus Unit Error.
0x250D	Unit Error: SYSMAC BUS No. duplication.
0x250F	Unit Error: Memory Error.
0x2510	Unit Error: SYSMAC BUS terminator missing.
0x2601	Command Error: No protection.
0x2602	Command Error: Incorrect password.
0x2604	Command Error: Protected.
0x2605	Command Error: Service already executing.
0x2606	Command Error: Service stopped.
0x2607	Command Error: No execution right.
0x2608	Command Error: Settings not complete.
0x2609	Command Error: Necessary items not set.
0x260A	Command Error: Number already defined.
0x260B	Command Error: Error will not clear.
0x3001	Access Right Error: No access right.
0x4001	Abort: Service aborted.

A

Siemens Error Code P499 Explanation

The P499 error code is used to show any errors that are generated by the connected PLC. The P499 error message includes a four digit hexadecimal value displayed at the end of the message. This value can be looked up in the specific PLC's error tables to determine the cause of the error. The possible PLC generated error codes for the Siemens PPI communication protocols breakdown into a four digit hexadecimal value as shown in the following diagram.

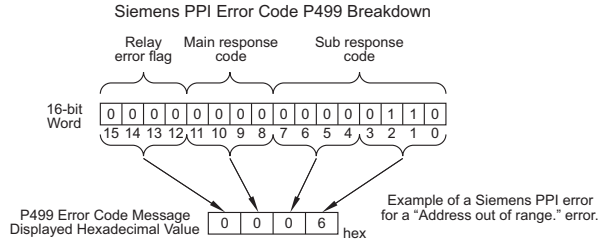

Siemens Error Code P499 Message Example:

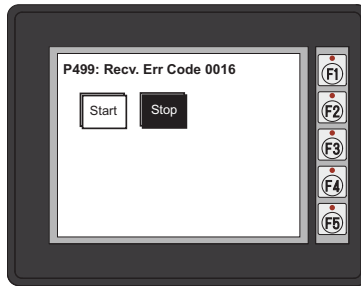

Siemens PPI Protocol – PLC Error Code Table

PLC PDU Header Errors for S7-200 PPI	
Panel Error Code P499 Hex Value	Description
0x0001	Hardware Fault.
0x0003	Object access not allowed.
0x0004	Context not supported.
0x0005	Address out of range.
0x0006	Address out of range.
0x0007	Write Data size mismatch.
0x000A	Object does not exist.
0x8000	Function being used.
0x8001	Action is not allowed in current mode.
0x8101	Hardware fault.
0x8103	Access not allowed.
0x8104	Function not supported.
0x8105	Address invalid.
0x8106	Data Type not supported.
0x8107	Data Type is not consistent with size.
0x810A	Object does not exist.
0x8500	PDU Size is incorrect.
0x8702	Address is invalid.
0xD201	Block name syntax error.
0xD202	Error with function parameter.
0xD203	Error with block type.
0xD204	No linked block.
0xD205	Object already exists.
0xD206	Object already exists.
0xD207	Block already used in EPROM.
0xD209	Block does not exist.
0xD20E	No Block does not exist.
0xD210	Block number incorrect.

C-MORE MICRO-GRAPHIC PANEL RUNTIME ERRORS



APPENDIX B

In This Appendix...

IntroductionB-2
Panel ErrorsB-2

Introduction

The runtime errors detected by the *C-more*® Micro-Graphic panel will display in a popup window in the center of the panel display. The most common cause for runtime errors is a bad serial connection during a project transfer or firmware update. To resolve the problem, try the following steps in the order shown:

1. Check that all connections are secure and cables are in good condition.
2. Cycle power to the panel.
3. Reset factory default system settings.
4. Transfer the project again.

Panel Errors

If more than one panel error occurs, each error message will display sequentially for three seconds with a two second delay between each message.

When only one panel error is active, that message will display continuously until it is no longer active.

Micro-Graphic Panel Errors		
Error Code	Error Message	Possible Solutions
R001	PC software tool Timeout	Check cables and connections. Cycle power at the panel.
R002	CRC Error occurred during project transfer from PC.	See Chapter 8 for Electrical Noise Problems. Check the area for sources of noise: electrical motors, transformers, etc. Check for proper grounding Resend the project.
R003	Project Check Sum Error. Resend Project file to Panel.	Cycle power. Resend the project.
R004	Protocol Module Check Sum Error. Resend Project File to Panel	
R005	Panel Check Sum Error. Panel Info (Not Project) will be initialized.	From the Setup Menu screen, reset panel options.
R006	SW Ver. Mismatch. Use software Ver.xx.xx.	Update to current version programming software and panel firmware.
R100	Option module detected without external power	EA-MG-SP1 or EA-MG-P1 optional power adapter module is installed on a C-more 3" Micro-Graphic panel without a 12-24 VDC power source. Provide 12-24 VDC power to the optional module.
R101	Unsupported module detected	EA-MG-SP1 or EA-MG-P1 optional power adapter module for a C-more 3" Micro-Graphic panel is installed on a C-more 6" Micro-Graphic panel. Remove the EA-MG-SP1 or EA-MG-P1.

INDEX



A

Accessories, 3–2

EA-6-COV2, 3–2, 3–15

EA-MG-PGM-CBL, 3–2, 3–6, 3–7

EA-MG-PGMSW, 3–2

EA-MG6-BZ2, 3–2, 3–9

EA-MG6-BZ2P, 3–2, 3–11, 3–12

Agency Approvals, 1–4

Available Models, 2–2

C

C-more Micro-Graphic Panel Runtime Errors, B–2

Introduction, B–2

Panel Errors, B–2

C-more Micro-Graphic Panel Runtime Errors, 8–9

C-more Micro-Graphic Programming Software, 3–3

Cables, 6–15

Cables from AutomationDirect, 6–15

Wiring Diagrams, 6–17, 6–18, 6–19, 6–20, 6–21, 6–22, 6–23, 6–24, 6–25

User Constructed Cables, 6–26

Wiring Diagrams, 6–26, 6–27, 6–28, 6–29, 6–30, 6–31

Chemical Compatibility, 2–7

Clear Screen Overlay, 3–15

Communication Port Adapters, 3–14

EA-ADPTR-4, 3–14

EA-COMCON-3, 3–14

Communications Ports, 2–6

Conventions Used, 1–3

exclamation mark, 1–3

notepad, 1–3

E

Enclosure Clearances, 1–10

Enclosure Thickness, 2–5

Error Code P499 Explanation, A–5

Allen-Bradley, A–6

DirectLOGIC, A–5

GE, A–11

Modbus, A–4

AutomationDirect CLICK, A–4

AutomationDirect DirectLOGIC - Modbus (Koyo), A–4

Entivity Modbus RTU, A–4

Modicon Modbus RTU, A–4

Omron, A–23

Siemens, A–28

Exit Menu item, 5–18

F

Function Keys Insert Label, 9–3

Customizing, 9–3

I

Installation, 4–3

Introduction, 1–2

K

Keypad Bezel, 20-Button Landscape, 3–8

Assembly, 3–10

Dimensions, 3–8

Specifications, 3–9

Keypad Bezel, 21-Button Portrait, 3–11

Assembly, 3–13

Dimensions, 3–11

Specifications, 3–12

L

Lost Firmware – Red ‘Update Mode’ Screen Displayed, 8–4

Low-Power Mode, 4–5, 5–10, 5–17

M

Maintenance, 7–2

Check Operating Environment, 7–2

Check Operating Voltage, 7–2

Check Physical Conditions, 7–3

Check Project Functionality, 7–6

Check Settings under the System Setup Screens, 7–5

Check Transmit and Receive Indicators, 7–3

Checks from the C-more Micro-Graphic Programming Software, 7–6

Cleaning the Display Screen, 7–5

Project Backup, 7–2

Run Tests under the System Setup Screens, 7–4

Mitsubishi Q / QnA Series, A–21, A–22

Modbus Protocols, A–4

Mounting Clip Screw Torque, 2–5

Mounting Clips, 4–3

P

Panel & PLC Error Code Tables, A–2

Allen-Bradley DF1 Protocol, A–7, A–8

Allen-Bradley DH485 Protocol, A–9, A–10

C-more Micro-Graphic Panel, A–3, A–4

DirectLOGIC – K-Sequence PLC, A–5

GE SNPX Protocol, A–12, A–13, A–14, A–15, A–16, A–17, A–18, A–19, A–20

Introduction, A–2

Mitsubishi FX Protocol, A–21

Omron FINS Protocol, A–25, A–26, A–27

Omron Host Link Protocol, A–24

Siemens PPI Protocol, A–29

Panel Cutout Dimensions (all models), 4–4

Panel Dimensions, 2–5

- Panel Objects, 3–4
 - Adjust Display Contrast, 3–5
 - Analog Meter, 3–4
 - Bar Meter, 3–4
 - Bitmap Button, 3–4
 - Circle, 3–4
 - Dynamic Bitmap, 3–5
 - Dynamic Text, 3–5
 - Frame, 3–4
 - Function, 3–5
 - Graphic Indicator Light, 3–4
 - Increment/Decrement Value, 3–4
 - Indicator Button, 3–4
 - Indicator Light, 3–4
 - Line, 3–4
 - Line Graph, 3–4
 - Lookup Text, 3–5
 - Numeric Display, 3–4
 - Numeric Entry, 3–4
 - Pushbutton, 3–4
 - Real Time Graph, 3–4
 - Recipe, 3–5
 - Rectangle, 3–4
 - Screen Change Pushbutton, 3–5
 - Screen Selector, 3–5
 - Scroll Text, 3–5
 - Static Bitmap, 3–4
 - Static Text, 3–5
 - Switch, 3–4
- Part Number Key, 1–5
 - Bezel Part Number Key, 1–5
 - Panel Part Number Key, 1–5
- PC Requirements, 3–3
- PLC Communications
 - Communication Ports, 6–4, 6–5
 - Introduction, 6–2, 6–3
- PLC Compatibility and Connection Charts, 6–6

Allen-Bradley PLCs, 6–13
AutomationDirect CLICK PLC, 6–9
DirectLOGIC DL05, DL06, D0-DCM Module & DL105 PLCs, 6–9
DirectLOGIC DL205 PLCs, D2-DCM Module and WINPLC, 6–10
DirectLOGIC DL305 PLCs and D3-DCM Module, 6–11
DirectLOGIC DL405 PLCs and D4-DCM Module, 6–12
GE, Mitsubishi, Omron, Modicon and Siemens PLCs, 6–14
Instructions for using, 6–8

Product Label Example, 1–5

Product Overview, 1–4

EA1-S6ML, 1–4

EA1-S6MLW, 1–4

Q

Quick Start Steps, 1–6

Step 1 – Unpack and Inspect, 1–6

Step 10 – Connect C-more 6” Micro-Graphic Panel to PLC, 1–16

Step 2 – Install Optional Hardware Accessories, 1–7

Step 3 – Become Familiar with Available Communication Ports, 1–8

Step 4 – Install C-more Micro-Graphic Panel, 1–9

Step 5 – Connect C-more 6” Micro-Graphic Panel to Computer, 1–12

Step 6 – Provide Power to the C-more 6” Micro-Graphic Panel, 1–13

Step 7 – Accessing the C-more 6” Micro-Graphic Panel Setup Screens, 1–14

Step 8 – Choose C-more 6” Micro-Graphic Panel to PLC Protocol & Cables, 1–15

R

Replacement Parts

DC Power Connector Part No. EA-MG-DC-CON, 9–2

Function Keys Label Inserts Part No. EA-MG-S3ML-FKL, 9–2

Keypad Bezel 1 Gasket Part No. EA-MG-BZ1-GSK, 9–2

Keypad Bezel 2 Mounting Clips Part No. EA-MG-BZ2-BRK, 9–2

Panel Gasket Part No. EA-MG-S3ML-GSK, 9–2

Replacement Parts at a Glance, 9–2

Replacement Parts Overview, 9–2

RS-422A/RS-485A Multi-Drop Wiring Diagram Examples, 6–32, 6–33, 6–34, 6–35

S

- Safety Guidelines, 4–2
- Serial Number and Date Code format, 1–5
- Setting Menu, 5–7
 - Backlight, Model EA1-S6ML, 5–8
 - Backlight, Model EA1-S6MLW, 5–9
 - Beep, 5–10
 - Calibration, 5–11
 - Clear User Memory, 5–12
 - Hourglass, 5–13
 - LCD Contrast, 5–7
 - Reset to Factory Default, 5–12
 - Rotation, 5–14
- Setup Menu, 5–5
 - Information Menu, 5–6
 - Extensions, 5–6
 - Memory, 5–6
 - Protocol, 5–6
 - Versions, 5–6
- Specifications, 2–3
- System Setup Screens, 5–2
 - Accessing, 5–3
 - Flowchart, 5–4
 - Information, 5–2
 - Introduction, 5–2
 - Setting, 5–2
 - Test Menu, 5–2

T

- Technical Support, 1–2
- Test Menu, 5–15
 - Buzzer Test, 5–17
 - PLC Enquiry Test, 5–17
 - Serial Port1 - Loop Back Test, 5–15
 - Serial Port2 - Loop Back Test, 5–16
 - Touch Panel Test, 5–18

Troubleshooting, 8–2

C-more Micro-Graphic Panel does not Power up, 8–2

Powered from 12-24 VDC, 8–2

Powered from 5 VDC, 8–2

Display is Blank, 8–2

Display is Dim, 8–3

Electrical Noise Problems, 8–10

No Communications between Panel and PC, 8–5

No Communications between Panel and PLC, 8–7

No User Program, 8–3

PLC Protocol Error Codes, 8–8

PLC Protocol Error Example, 8–8

U

Updating Firmware, 8–4

USB to RS-232 Programming Cable Assembly, 1–12, 3–6

converter, 3–6

Specifications, 3–7

W

Wiring Guidelines, 4–5

