

# DL05/06 I/O Option Modules

## F0-08DAH-1 <--->

8-channel analog current output module, high resolution

Output Specifications	
<b>Number of Channels</b>	8
<b>Output Range</b>	4-20mA
<b>Resolution</b>	16-bit, .244µA/bit
<b>Output Type</b>	Current sourcing at 20mA max.
<b>PLC Data Format</b>	16-bit, Unsigned Int., 0-FFFF (binary) or 0-65535 (BCD) (Both require 2 words of V-memory)
<b>Output value in program mode</b>	4mA
<b>Load Impedance</b>	250-750 Ohms
<b>Maximum Inductive Load</b>	1 mH
<b>Allowed load type</b>	Grounded
<b>Maximum Inaccuracy</b>	0.2% of range
<b>Maximum Full Scale Calibration Error (not including offset error)</b>	±.025% of range maximum
<b>Maximum Offset Calibration Error</b>	±.025% of range maximum
<b>Accuracy vs. Temperature</b>	±50 ppm/ °C maximum full scale calibration change
<b>Maximum Crosstalk</b>	±10 counts
<b>Linearity Error (End to End)</b>	±16 count maximum (±0.025% of full scale) Monotonic with no missing codes
<b>Output Stability and Repeatability</b>	±10 counts after 10 min. warm-up typical
<b>Output Ripple</b>	.05% of Full Scale
<b>Output Settling Time</b>	.5 ms max., 5 µs min. (full scale change)
<b>All Channel Update Rate</b>	100µs
<b>Maximum Continuous Overload</b>	Outputs open circuit protected
<b>Type of Output Protection</b>	Electronically current limited to 20mA or less
<b>Output signal at power-up and power-down</b>	4mA
<b>Terminal Type (Included)</b>	Removable: D0-ACC-4
<b>External 24VDC Power Required</b>	220mA
<b>Base Power Required (5.0V)</b>	25mA

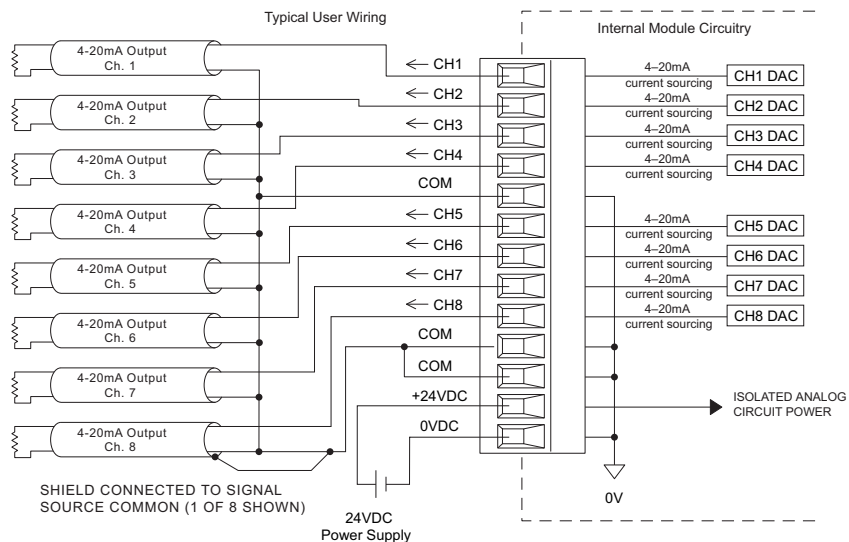
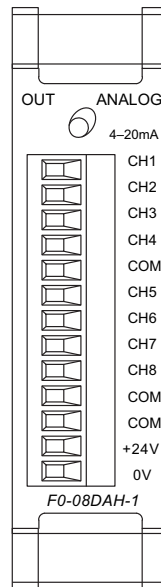

CPU	Firmware Required	DirectSOFT Required
DL05	Version 5.20 or later	DirectSOFT32 Version 3.0c or later
DL06	Version 2.30 or later	DirectSOFT32 Version 4.0, Build 16 or later



See page 2-68 for part numbers of ZIPLink cables and connection modules compatible with this I/O module.

## Cut PLC wiring time to minutes instead of hours

The ZIPLink wiring system eliminates the normally tedious process of wiring PLC I/O to terminal blocks. Simply plug one end of a ZIPLink pre-wired terminal block cable into your I/O module and the other end into a ZIPLink connector module. It's that easy. ZIPLinks use half the space, at a fraction of the total cost of terminal blocks.

ZIPLinks are available in a variety of styles to suit your needs, including fused, relay and sensor/LED connector modules. ZIPLinks are available for all DL05/06 Series PLC discrete and analog input and output modules.

For complete information see ZIPLinks in the Terminal Blocks and Wiring Solutions section.



## Specify your ZIPLink system

Use the Compatibility Matrix table below:

<b>Step 1</b>	Locate the I/O Module part number.
<b>Step 2</b>	Locate Connector Module Type. (Feedthrough Module, Fuse Module, etc...)
<b>Step 3</b>	Select the cable length by replacing the # symbol with: Blank = 0.5m, -1 = 1m, -2 = 2m <sup>1</sup>
<sup>1</sup> Note: Cable part number denotes compatibility between Connector Module and I/O Modules.	

ZIPLink Wiring System Compatibility Matrix for DL05/06 PLCs						
Step 2: Connector Module Type		Feedthrough Modules	Fuse Modules	Relay Modules	Sensor Input Modules	Pigtail Cable
Step 1: I/O Module	Number of Terminals	ZL-RTB20	ZL-RFU20	ZL-RRL16-24	ZL-LTB16-24	
		Step 3: Cables				
<b>Inputs</b>						
<b>DO-10ND3</b>	13	ZL-D0-CBL13#				
<b>DO-10ND3F</b>	13	ZL-D0-CBL13#				
<b>DO-16ND3</b>	24	ZL-D0-CBL24#L			ZL-D0-CBL24#L	ZL-D0-CBL24#P
<b>FO-08NA-1</b>	10	ZL-D0-CBL10#				
<b>Outputs</b>						
<b>DO-10TD1</b>	13	ZL-D0-CBL13#				
<b>DO-16TD1</b>	24	ZL-D0-CBL24#	ZL-D0-CBL24#	ZL-D0-CBL24#		ZL-D0-CBL24#P
<b>DO-10TD2</b>	13	ZL-D0-CBL13#				
<b>DO-16TD2</b>	24	ZL-D0-CBL24#	ZL-D0-CBL24#			ZL-D0-CBL24#P
<b>DO-08TR</b>	10	ZL-D0-CBL10#				
<b>FO-04TRS*</b>	13	ZL-D0-CBL13#				
<b>Combo In/Out</b>						
<b>DO-07CDR</b>	10	ZL-D0-CBL10#				
<b>DO-08CDD1</b>	13	ZL-D0-CBL13#				
<b>Analog</b>						
<b>FO-04AD-1</b>	8	ZL-D0-CBL8#				
<b>FO-04AD-2</b>	8	ZL-D0-CBL8#				
<b>FO-08ADH-1</b>	13	ZL-D0-CBL13#				
<b>FO-08ADH-2</b>	13	ZL-D0-CBL13#				
<b>FO-04DAH-1</b>	13	ZL-D0-CBL13#				
<b>FO-08DAH-1</b>	13	ZL-D0-CBL13#				
<b>FO-04DAH-2</b>	13	ZL-D0-CBL13#				
<b>FO-08DAH-2</b>	13	ZL-D0-CBL13#				
<b>FO-2AD2DA-2</b>	8	ZL-D0-CBL8#				
<b>FO-4AD2DA-1</b>	8	ZL-D0-CBL8#				
<b>FO-4AD2DA-2</b>	8	ZL-D0-CBL8#				
<b>FO-04RTD**</b>						
<b>FO-04THM**</b>						

\* Caution: The FO-04TRS relay outputs are derated not to exceed 2 Amps per point when used with the ZIPLink wiring system.

\*\* The F2-04RTD and F2-04THM modules are not supported by the ZIPLink wiring system. These modules require wire specific to the signal type.

ZIPLink Connector Modules and cable specifications are shown in Terminal Blocks and Wiring Section

# Power Budgeting for the DL06

The DL06 has four option module slots. To determine whether the combination of modules you select will have sufficient power, you will need to perform a power budget calculation.

## Power supplied

Power is supplied from two sources: the internal base unit power supply and, if required, an external supply (customer furnished). The D0-06xx (AC powered) PLCs supply a limited amount of 24 VDC power. The 24 VDC output can be used to power external devices.

For power budgeting, start by considering the power supplied by the base unit. All DL06 PLCs supply the same amount of 5 VDC power. Only the AC units offer 24 VDC auxiliary power.

Be aware of the trade-off between 5 VDC power and 24 VDC power. The amount of 5 VDC power available depends on the amount of 24 VDC power being used, and the amount of 24 VDC power available depends on the amount of 5 VDC power consumed. Determine the amount of internally supplied power from the table to the right.

## Power required by base unit

Because of the different I/O configurations available in the DL06 family, the power consumed by the base unit itself varies from model to model. Subtract the amount of power *required* by the base unit from the amount of power *supplied* by the base unit. Be sure to subtract 5 VDC and 24 VDC amounts.

## Power required by option modules

Next, subtract the amount of power required by the option modules you are planning to use. Again, remember to subtract both 5 VDC and 24 VDC.

If your power budget analysis shows surplus power available, you should have a workable configuration.

DL06 Power Supplied by Base Units		
Part Number	5 VDC (mA)	24 VDC (mA)
D0-06xx	1500mA	300mA
	2000mA	200mA
D0-06xx-D	1500mA	none

DL06 Base Unit Power Required		
Part Number	5 VDC (mA)	24 VDC (mA)
D0-06AA	800mA	none
D0-06AR	900mA	none
D0-06DA	800mA	none
D0-06DD1	600mA	280mA*
D0-06DD2	600mA	none
D0-06DR	950mA	none
D0-06DD1-D	600mA	none
D0-06DD2-D	600mA	none
D0-06DR-D	950mA	none

\* Only if auxiliary 24VDC power is connected to V+ terminal.

DL06 Power Consumed by Other Devices		
Part Number	5 VDC (mA)	24 VDC (mA)
D0-06LCD	50mA	none
D2-HPP	200mA	none
DV-1000	150mA	none
C-more Micro-Graphic	210mA	none

Power Budgeting Example		
Power Source	5VDC power (mA)	24VDC power (mA)
D0-06DD1 (select row A or B)	A	1500mA
	B	2000mA
<b>Current Required</b>	<b>5VDC power (mA)</b>	<b>24VDC power (mA)</b>
D0-06DD1	600mA	280mA*
D0-16ND3	35mA	0
D0-10TD1	150mA	0
D0-08TR	280mA	0
F0-4AD2DA-1	100mA	0
D0-06LCD	50mA	0
<b>Total Used</b>	<b>1215mA</b>	<b>280mA</b>
<b>Remaining</b>	A	285mA
	B	785mA

\* Auxiliary 24 VDC used to power V+ terminal of D0-06DD1 sinking outputs.

**Note 1: If the PLC's auxiliary 24 VDC power source is used to power the sinking outputs, use power choice A, above.**

DL05/06 Power Consumed by Option Modules		
Part Number	5 VDC (mA)	24 VDC (mA)
D0-07CDR	130mA	none
D0-08CDD1	100mA	none
D0-08TR	280mA	none
D0-10ND3	35mA	none
D0-10ND3F	35mA	none
D0-10TD1	150mA	none
D0-10TD2	150mA	none
D0-16ND3	35mA	none
D0-16TD1	200mA	none
D0-16TD2	200mA	none
F0-04TRS	250mA	none
F0-08NA-1	5mA	none
F0-04AD-1	50mA	none
F0-04AD-2	75mA	none
F0-08ADH-1	25mA	25mA
F0-08ADH-2	25mA	25mA
F0-04DAH-1	25mA	150mA
F0-08DAH-1	25mA	220mA
F0-04DAH-2	25mA	30mA
F0-08DAH-2	25mA	30mA
F0-2AD2DA-2	50mA	30mA
F0-4AD2DA-1	100mA	40mA
F0-4AD2DA-2	100mA	none
F0-04RTD	70mA	none
F0-04THM	30mA	none
D0-DEVNETS	45mA	none
H0-PSCM	530mA	none
H0-ECOM	250mA	none
H0-CTRIO	250mA	none
H0-ECOM100	300mA	none
F0-08SIM	1mA	none
D0-DCM	250 mA	none
F0-CP128	150 mA	none
F0-08SIM	1 mA	none