

Analog Voltage Output Modules

F2-02DA-2 2-Channel Voltage Analog Output <--->	
This module requires a 24 VDC user power supply for operation. See the F2-02DA-2L on the next page if you want to use a 12 VDC supply. All other specifications are the same.	
Number of Channels	2
Output Ranges	0 to 5V, 0 to 10 V, $\pm 5V$, $\pm 10 V$
Resolution	12 bit (1 in 4096)
Output Type	Single ended, 1 common
Digital Output Points Required	16 (Y) output points (12 binary data bits, 2 channel ID bits)
Peak Output Voltage	15 VDC (clamped by transient voltage suppressor)
Load Impedance	2000 Ω minimum
Load Capacitance	.01 μF maximum
PLC Update Rate	1 channel per scan maximum D2-230 CPU 2 channels per scan maximum (D2-240, D2-250(-1) and D2-260 CPUs)
Linearity Error (end to end)	± 1 count (0.025% of full scale) maximum
Conversion Settling Time	5 μs maximum (full scale change)
Full Scale Calibration Error (offset error included)	± 12 counts max. unipolar @ 77°F (25°C) ± 16 counts max. bipolar @ 77°F (25°C)
Offset Calibration Error	± 3 counts max., unipolar @ 77°F (25°C) ± 8 counts max., bipolar @ 77°F (25°C)

See page 4-78 for part numbers of ZILink cables and connection modules compatible with this I/O module.



Accuracy vs. Temperature	± 50 ppm/ $^{\circ}C$ full scale calibration change (including maximum offset change of 2 counts)
Maximum Inaccuracy	+0.3% unipolar ranges @ 77°F (25°C) $\pm 0.45\%$ unipolar ranges >77°F (25°C) $\pm 0.4\%$ bipolar ranges @ 77°F (25°C) $\pm 0.55\%$ bipolar ranges >77°F (25°C)
Base Power Required 5VDC	40 mA
External Power Supply	18 to 30 VDC, 60 mA (outputs fully loaded)
Operating Temperature	32° to 140°F (0° to 60°C)
Storage Temperature	-4° to 158°F (-20° to 70°C)
Relative Humidity	5 to 95% (non-condensing)
Environmental Air	No corrosive gases permitted
Vibration	MIL STD 810C 514.2
Shock	MIL STD 810C 516.2
Noise Immunity	NEMA ICS3-304
Terminal Type (included)	Removable; D2-810CON

One count in the specification table is equal to one least significant bit of the analog data value (1 in 4096).

NOTE 1: Shields should be connected to the 0V of the module or the 0V of the R/S.

NOTE 2: Unused voltage outputs should remain open (no connections) for minimum power consumption.

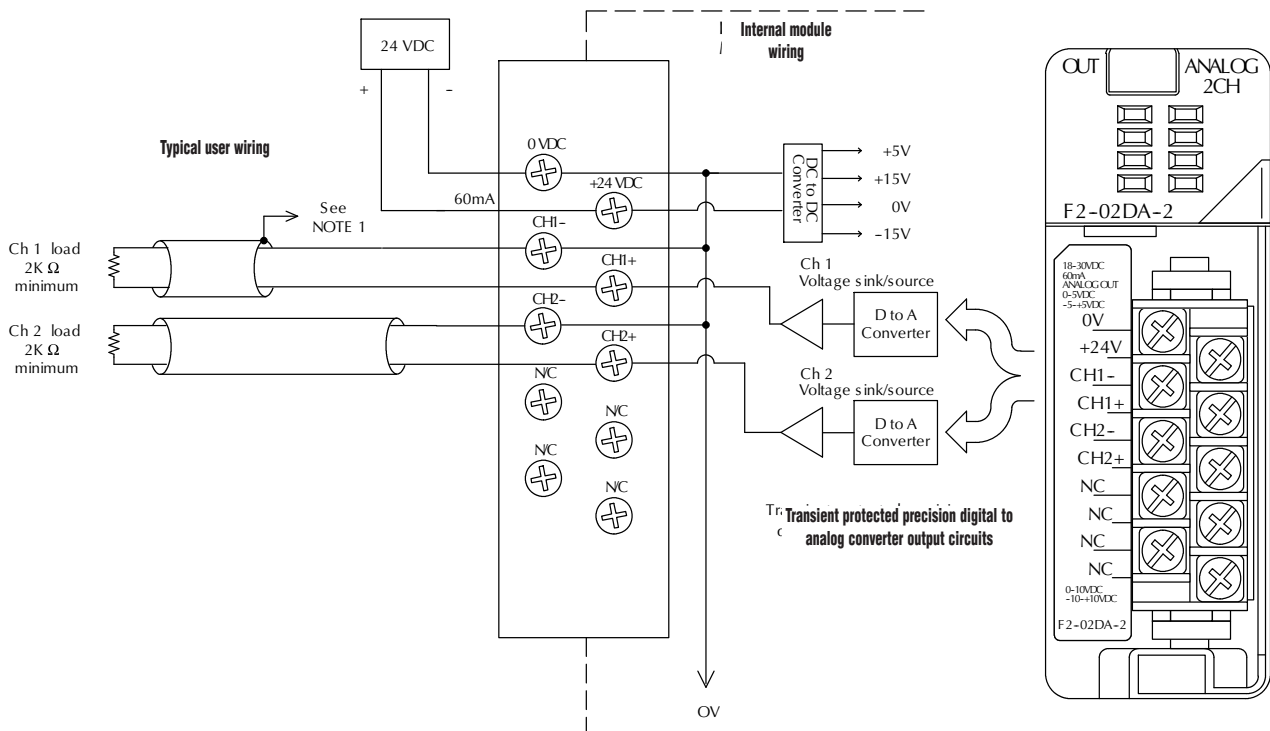

Step 1	Locate the I/O module part number.
Step 2	Locate Connector Module Type. (Feedthrough Module, Fuse Module, etc...)
Step 3	Select the cable length by replacing the # symbol with: Blank = 0.5m, -1 = 1.0m, -2 = 2.0m ¹
¹ Note: Cable part number denotes compatibility between Connector Module and I/O Modules.	

ZIPLink Wiring System Compatibility Matrix for DL205 PLCs Continued									
Step 2: Connector Module Type		Feedthrough Modules		Fuse Modules		Relay Modules	Sensor Input Modules		Pigtail Cable
Step 1: I/O Module	Number of Terminals	ZL-RTB20	ZL-RTB40	ZL-RFU20	ZL-RFU40	ZL-RRL16-24	ZL-LTB16-24	ZL-LTB32-24	
Step 3: Cables									
Analog									
I/O Module	F2-04AD-1	10	ZL-D2-CBL10#						
	F2-04AD-1L	10	ZL-D2-CBL10#						
	F2-08AD-1	10	ZL-D2-CBL10#						
	F2-04AD-2	10	ZL-D2-CBL10#						
	F2-04AD-2L	10	ZL-D2-CBL10#						
	F2-08AD-2	10	ZL-D2-CBL10#						
	F2-02DA-1	10	ZL-D2-CBL10#						
	F2-02DA-1L	10	ZL-D2-CBL10#						
	F2-02DAS-1	10	ZL-D2-CBL10#						
	F2-08DA-1	19	ZL-D2-CBL19#						ZL-D2-CBL19#P
	F2-02DA-2	10	ZL-D2-CBL10#						
	F2-02DA-2L	10	ZL-D2-CBL10#						
	F2-02DAS-2	10	ZL-D2-CBL10#						
	F2-08DA-2	10	ZL-D2-CBL10#						
	F2-4AD2DA	10	ZL-D2-CBL10#						
	F2-8AD4DA-1	19	ZL-D2-CBL19#						ZL-D2-CBL19#P
	F2-8AD4DA-2	19	ZL-D2-CBL19#						ZL-D2-CBL19#P
	F2-04RTD*								
F2-04THM*									

*The F2-04RTD and F2-04THM modules are not supported by the ZIPLink wiring system. These modules require wire specific to the signal type.

ZIPLink Connector Module and Cable specifications found in Terminal Blocks and Wiring section

Power Requirements

These charts help determine your power requirements

This section shows the amount of power supplied by each of the base power supplies and the amount of power consumed by each DL205 device. The Power Consumed charts list how much INTERNAL power from each power source is required for the DL205 devices. Use this information when calculating the power budget for your system.

In addition to the internal power sources, the DL205 bases offer a 24 VDC auxiliary power supply with external power connections. This auxiliary power supply can power external devices.

Use ZIPLinks to reduce power requirements

If your application requires a lot of relay outputs, consider using the ZIPLink AC or DC relay output modules. These modules can switch high current (10A) loads without putting a load on your base power budget. Refer to the Terminal Blocks and Wiring Solutions section in this catalog for more information.

This logo is placed next to the I/O modules that are supported by the ZIPLink connection systems. See the I/O module specifications at the end of this section.



Power Consumed		
Device	5V(mA)	24V Auxiliary
Operator Interface		
DV-1000	150	0
C-more Micro-Graphic	210	0

Power Supplied							
Device	Price	5V(mA)	24V Auxiliary	Device	Price	5V(mA)	24V Auxiliary
Bases				Bases			
D2-03B-1	<--->	2600	300	D2-06BDC1-1	<--->	2600	None
D2-03BDC1-1	<--->	2600	None	D2-06BDC2-1	<--->	2600	300
D2-04B-1	<--->	2600	300	D2-09B-1	<--->	2600	300
D2-04BDC1-1	<--->	2600	None	D2-09BDC1-1	<--->	2600	None
D2-06B-1	<--->	2600	300	D2-09BDC2-1	<--->	2600	300

Power Consumed		
Device	5V(mA)	24V Auxiliary
CPUs		
D2-230	120	0
D2-240	120	0
D2-250-1	330	0
D2-260	330	0
H2-WPLC**	680	0
DC Input Modules		
D2-08ND3	50	0
D2-16ND3-2	100	0
D2-32ND3	25	0
D2-32ND3-2	25	0
AC Input Modules		
D2-08NA-1	50	0
D2-08NA-2	100	0
D2-16NA	100	0
Input Simulator Module		
F2-08SIM	50	0
DC Output Modules		
D2-04TD1	60	20
D2-08TD1	100	0
D2-08TD2	100	0
D2-16TD1-2	200	80
D2-16TD2-2	200	0
F2-16TD1P	70	50
F2-16TD2P	70	50
D2-32TD1	350	0
D2-32TD2	350	0
AC Output Modules		
D2-08TA	250	0
F2-08TA	250	0
D2-12TA	350	0
Relay Output Modules		
D2-04TRS	250	0
D2-08TR	250	0
F2-08TR(S)	670	0
D2-12TR	450	0
Combination In/Out Module		
D2-08CDR	200	0

Power Consumed		
Device	5V(mA)	24V Auxiliary
Analog Modules		
F2-04AD-1	100	5
F2-04AD-2	110	5
F2-08AD-1	100	5
F2-08AD-2	100	5
F2-02DA-1	40	60 (note 1)
F2-02DA-1L	40	70 @ 12V (note 1)
F2-02DA-2	40	60
F2-02DA-2L	40	70 @ 12V
F2-02DAS-1	100	50 / channel
F2-02DAS-2	100	60 / channel
F2-08DA-1	30	50 (note 1)
F2-08DA-2	60	140
F2-4AD2DA	60	80 (note 1)
F2-8AD4DA-1	35	100 (note 1)
F2-8AD4DA-2	35	80 (note 1)
F2-04RTD	90	0
F2-04THM	110	60
Specialty Modules		
D2-CTRINT	50*	0
D2-CM / D2-EM	100/130	0
H2-CTRIO	400	0
D2-DCM	300	0
F2-DEVNETS	160	0
F2-SDS-1	160	0
H2-PBC	530	0
H2-EBC(-F)	450, (640)	0
H2-ECOM(-F)	450, (640)	0
H2-ECOM100	300	0
F2-CP128	235	0
Remote I/O		
H2-ERM(-F)	320, (450)	0
D2-RMSM	200	0
D2-RSSS	150	0
Programming Devices		
D2-HPP	200	0

*requires external 5VDC for outputs
Note 1: Add an additional 20 mA per output loop.