

Handwheel HKS...

Extremely operator-friendly and very robust spoke handwheel made of cast aluminium.

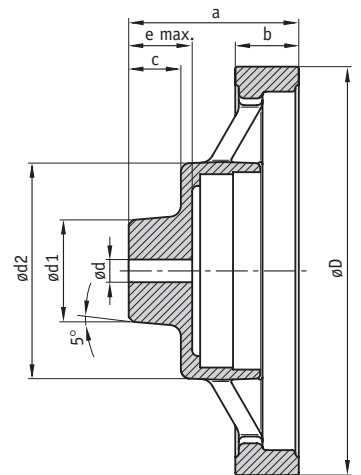

Features:

- robust design
- bored for S80/1 or SZ80/1

Option:

- various hub options
- surface plastic coated

Type	øD	ødv	ødx	ød1	ød2	a	b	c	e	Suitable for	Weight
HKS 18	180	7.8	30	45	95	75	28	23	25	S80/1; SZ80/1	0.9 kg

dv = d pre-drilled; dx = d max.

Feature	Ordering data	Technical data	Additional information
Handwheel HKS...	A	see table above	
Surface	B C	without varnish plastic coat, hammer finish, light grey	standard
Bore ød	d pre-dr. ...	pre-drilled, see table above, value ødv d max. in mm steps (H7)	standard see table above (smallest bore corresponding to d pre-dr.)
Key groove	OP JS9 P9	without key groove transition fit press fit	standard acc. to DIN 6885 T1 acc. to DIN 6885 T1
Pin hole (only without key groove)	OS No. x ø/f	without pin hole see fold-out page	standard no. of pinholes x diameter/dimension f e.g. 2x3.8/12
Hub thread	ONG No. x ø/f	without hub thread see fold-out page	standard no. of hub threads x diameter/dimension f e.g. 2xM4/12
Turned-down hub	OAN d1 (f7)xl	without turned-down hub see fold-out page	standard dependent on d max.
Position indicator mounted (*)	PM PS	position indicator mounted position indicator separate	standard
Material		handwheel: Duroplast black	hub: aluminium

* separate ordering of a position indicator necessary! (> see pages 9/10)

Your ordering data: - - - - - - - -