

Profile

- Premium knurled aluminum handwheel
- Compact design
- Various sizes
- Surface plastic-coated, anodized or bright-finished
- Various hub versions

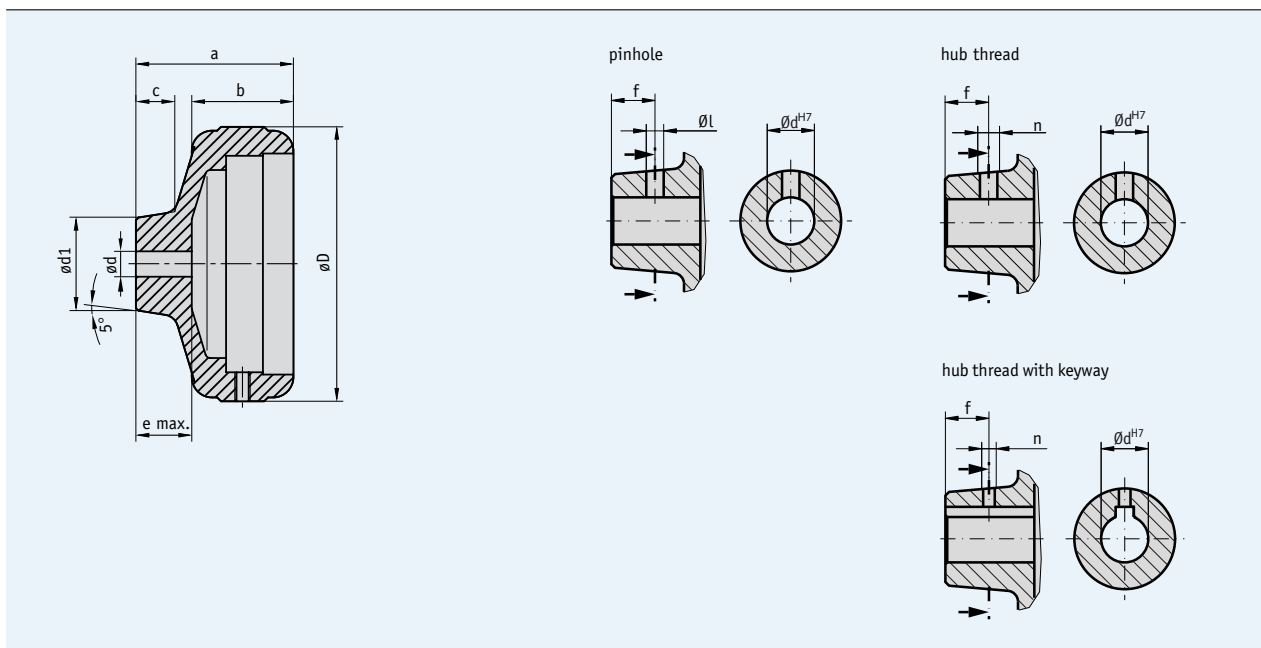

Mechanical data

■ Dimensions

type	ØD	Ødv	Ødx	Ød1	a	b	c	e	suitable for	weight	material
HR 6	65	5.8	20	30	50	35	15	20	S50/1	0.3 kg	aluminum
HR 11	108	6.8	20	36	62	40	15	22	S80/1; SZ80/1	0.5 kg	aluminum

dv = d predrilled; dx = d max.

■ Special versions

Handwheel type	HR 6					HR 11				
	6 ... 8	9, 10	11, 12	13 ... 16	17 ... 20	7, 8	9, 10	11, 12	13 ... 17	18 ... 20
Bore dH7	6 ... 8	9, 10	11, 12	13 ... 16	17 ... 20	7, 8	9, 10	11, 12	13 ... 17	18 ... 20
Groove width for keyway JS9		3	4	5			3	4	5	6
Pinhole	3.8/10	3.8/10	3.8/10	4.8/10		3.8/10	3.8/10	3.8/10	4.8/10	4.8/10
Hub thread	without keyway JS9	M4/10	M4/10	M4/10	M6/10		M4/10	M4/10	M4/10	M6/10
	with keyway JS9		M3/10	M3/10	M4/10		M3/10	M3/10	M4/10	

Additional special versions available on request. Note: Characters highlighted in orange are order features.

Order

Order table

Feature	Order data	Technical data	Additional information
Handwheel type	HR... A	6, 11	see "Dimensions"
Surface	B	unvarnished	
	ES	black anodized	
	EF	natural anodized	
		others on request	
Bore \emptyset d	d vorg.	predrilled	see "Dimensions", value \emptyset dv
	...	6 ... 16 d max. in mm steps (H7)	see "Dimensions"
Keyway	OP	without keyway	
	JS9	light seat	according to DIN 6885 T1
	P9	tight seat	according to DIN 6885 T1
Pinhole (only without keyway)	OS	without pinhole	
	...	diameter " \emptyset l"/measure "f" (e.g., 3.8/10)	see table "Special versions", depending on handwheel type, only if hub thread "ONG"
		others on request	
Hub thread	ONG	without hub thread	
	...	thread "n"/measure "f" (e.g., M4/10)	see table "Special versions", depending on handwheel type, only if pinhole "OS"
		others on request	
Hub turned down	OAN	without turned-down hub	
		others on request	
Position indicator mounted (*)	PM	position indicator mounted	
	PS	separate position indicator	

* separate order of a position indicator required (see pages 68-77)

Order code



Scope of delivery: HR...

Accessories:

End plate

Page 99

Additional information:

General information and areas of application

Page 62 cont.